



Det här verket är upphovrättskyddat enligt *Lagen (1960:729) om upphovsrätt till litterära och konstnärliga verk*. Det har digitaliserats med stöd av Kap. 1, 16 § första stycket p 1, för forskningsändamål, och får inte spridas vidare till allmänheten utan upphovsrättsinnehavarens medgivande.

Alla tryckta texter är OCR-tolkade till maskinläsbar text. Det betyder att du kan söka och kopiera texten från dokumentet. Vissa äldre dokument med dåligt tryck kan vara svåra att OCR-tolka korrekt vilket medför att den OCR-tolkade texten kan innehålla fel och därför bör man visuellt jämföra med verkets bilder för att avgöra vad som är riktigt.

This work is protected by Swedish Copyright Law (*Lagen (1960:729) om upphovsrätt till litterära och konstnärliga verk*). It has been digitized with support of Kap. 1, 16 § första stycket p 1, for scientific purpose, and may no be disseminated to the public without consent of the copyright holder.

All printed texts have been OCR-processed and converted to machine readable text. This means that you can search and copy text from the document. Some early printed books are hard to OCR-process correctly and the text may contain errors, so one should always visually compare it with the images to determine what is correct.



Diss 99.571

ON BONE QUALITY AND IMPLANT STABILITY MEASUREMENTS

Bertil Friberg

Göteborg 1999

GÖTEBORGS UNIVERSITETSBIBLIOTEK



14000

000967912

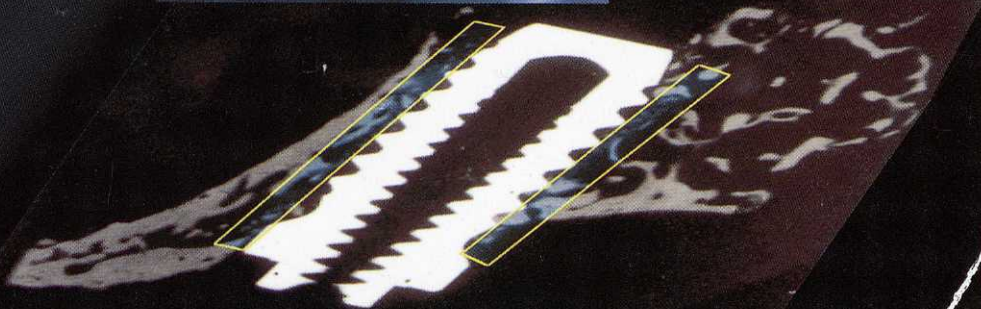
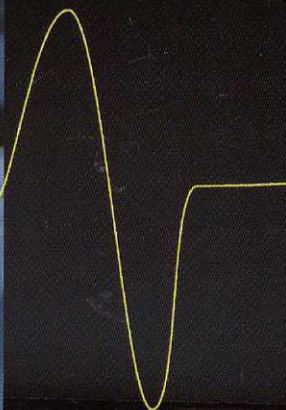
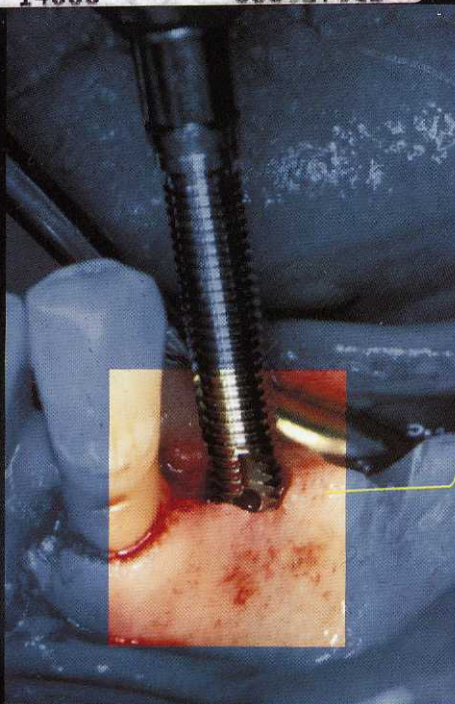



Biomedicinska biblioteket

diss 99.571

ON BONE QUALITY AND IMPLANT STABILITY MEASUREMENTS

AKADEMISK AVHANDLING

som för avläggande av odontologie doktorsexamen vid Göteborgs Universitet kommer att offentligens försvaras i föreläsningssal 3, Odontologiska Kliniken, Medicinargatan 12D, fredagen den 12 november, 1999, kl. 09.00.

av

BERTIL FRIBERG
leg. tandläkare, odont.lic

Avhandlingen baseras på följande delarbeten:

- I. **Friberg B, Jemt T, Lekholm U.** Early failures in 4,641 consecutively placed Brånemark dental implants: A study from stage 1 surgery to the connection of completed prostheses.
Int J Oral Maxillofac Impl 1991; 6: 142-146.
- II. **Friberg B, Sennerby L, Roos J, Johansson P, Strid K-G, Lekholm U.** Evaluation of bone density using cutting resistance measurements and microradiography. An in vitro study in pig ribs.
Clin Oral Impl Res 1995; 6: 164-171.
- III. **Friberg B, Sennerby L, Roos J, Lekholm U.** Identification of bone quality in conjunction with insertion of titanium implants. A pilot study in jaw autopsy specimens.
Clin Oral Impl Res 1995; 6: 213-219.
- IV. **Friberg B, Sennerby L, Gröndahl K, Bergström C, Bäck T, Lekholm U.** On cutting torque measurements during implant placement. A 3-year clinical prospective study.
Clin Impl Dent Rel Res 1999; in press.
- V. **Friberg B, Sennerby L, Meredith N, Lekholm U.** A comparison between cutting torque and resonance frequency measurements of maxillary implants. A 20-month clinical study.
Int J Oral Maxillofac Surg 1999; 28: 297-303.
- VI. **Friberg B, Sennerby L, Lindén B, Gröndahl K, Lekholm U.** Stability measurements of one-stage Brånemark implants during healing in mandibles. A clinical resonance frequency analysis study.
Int J Oral Maxillofac Surg 1999; 28: 266-272.

ABSTRACT

ON BONE QUALITY AND IMPLANT STABILITY MEASUREMENTS.

Bertil Friberg, Department of Biomaterials/Handicap Research, Institute for Surgical Sciences, Göteborg University and The Brånemark Clinic, Göteborg, Sweden.

In conjunction with placement of oral implants the jaw bone quality assessment is mainly based on quantitative radiographic measures and the subjective opinion of the performing surgeon. While the primary implant stability is discussed in terms of the pre-set motor torque and the subjective hand-felt perception during final tightening of implants, the secondary stability is defined as the absence of implant mobility. The objectives of the present thesis were to evaluate the technique of true cutting resistance, designed to define and objectively measure the bone quality or bone hardness, with regard to its reliability and applicability to the clinical situation. Correlation analyses were performed between values of cutting resistance and bone density, as well as between cutting resistance and total bone area of maxillae and mandibles. Further, the resonance frequency technique was utilized, aiming at objectively measure the obtained primary and secondary implant stabilities in maxillae and mandibles. Correlation analyses were performed between values of cutting torque and resonance frequency. The one-stage surgical protocol was executed in mandibles for repeated stability measurements during healing. Implants placed according to the two-stage surgical protocol, using the standard and an adapted preparation technique with extended healing periods, were compared with regard to various failure patterns.

The true cutting resistance technique was found reliable and applicable to the clinical situation, and significant correlations were demonstrated between the measured bone density and total bone area, respectively, and values of cutting resistance. Significantly more total bone, i.e. mainly compact bone, was seen in mandibles as compared to maxillae and values of cutting resistance were significantly higher in mandibles. No lower limit value at which implants were at risk was possible to identify, since cutting torque values were similar for successful and failed implants. Implant stability, as measured with resonance frequency, increased more in bone of low density than in bone of medium or high density during healing and initial loading periods. A significant correlation between the values of cutting torque of the crestal bone and resonance frequency was observed. While the implant outcome was favourable using the one-stage protocol and no increase in stability was demonstrated for implants placed in the anterior mandible, a concept of one-stage surgery and direct loading may be recommended for implants inserted in similar bone texture. The early failure rate was found equal (1.5%) for the two separately conducted two-stage surgical approaches, and implants in maxillae failed to a higher extent than mandibular ones. When using a standard treatment protocol, limited bone volume and poor bone texture were major determinants for early failures. When using an adapted preparation technique and extended healing, no such early failure patterns were seen. With regard to late failures, implants placed in maxillary bone of limited volume still represented more failures, while no such finding was demonstrated in bone of poor texture. Thus, early and late implant failure rates were equally low in bone of poor texture, when using the adapted surgical technique.

Keywords: early failures, titanium implants, jaw bone quality, jaw bone volume, cutting torque, implant stability, resonance frequency, one-stage surgery,

ISBN 91-628-3863-6

Correspondence: Dr Bertil Friberg, The Brånemark Clinic, Public Dental Health Care, Medicinaregatan 12C, SE 413 90 Göteborg, Sweden.

ON BONE QUALITY AND IMPLANT STABILITY MEASUREMENTS

by

Bertil Friberg



Department of Biomaterials/Handicap Research, Institute for Surgical
Sciences, Faculty of Medicine
and
The Brånemark Clinic, Faculty of Odontology,
Göteborg University, Göteborg, Sweden



BRÅNEMARK CLINIC
Dental Health Care Gothenburg

Göteborg 1999



This PhD thesis represents number 20 in a series of investigations on implants, hard tissue and the locomotor apparatus originating from the Department of Biomaterials/ Handicap Research, Institute for Surgical Sciences, Göteborg University, Sweden

1. **Anders R Eriksson DDS, 1984.** Heat-induced Bone Tissue Injury. An in vivo investigation of heat tolerance of bone tissue and temperature rise in the drilling of cortical bone. Thesis defended 21.2.1984.
2. **Magnus Jacobsson MD, 1985.** On Bone Behaviour after Irradiation. Thesis defended 29.4.1985.
3. **Fredrik Buch MD, 1985.** On Electrical Stimulation of Bone Tissue. Thesis defended 28.5.1985.
4. **Peter Kälebo MD, 1989.** On Experimental Bone Regeneration in Titanium implants. A Quantitative microradiographic and histologic investigation using the Bone Harvest Chamber. Thesis defended 1.10.1989.
5. **Lars Carlsson MD, 1989.** On the Development of a new Concept for Orthopaedic Implant Fixation. Thesis defended 2.12.1989.
6. **Tord Röstlund MD, 1990.** On the Development of a New Arthroplasty. Thesis defended 19.1.1990.
7. **Carina Johansson, Techn Res, 1991.** On Tissue Reactions to Metal Implants. Thesis defended 12.4.1991.
8. **Lars Sennerby, DDS, 1991.** On the Bone Tissue Response to Titanium Implants. Thesis defended 24.9.1991.
9. **Per Morberg MD, 1991.** On Bone Tissue Reactions to Acrylic Cement. Thesis defended 19.12.1991.
10. **Ulla Myhr PT, 1994.** On Factors of Importance for Sitting in Children with Cerebral Palsy. Thesis defended 15.4.1994.
11. **Magnus Gottlander MD, 1994.** On Hard Tissue Reactions to Hydroxyapatite-Coated Titanium Implants. Thesis defended 25.11.1994.
12. **Edward Ebramzadeh MSCEng, 1995.** On Factors Affecting Long-Term Outcome of Total Hip Replacements. Thesis defended 6.2.1995.
13. **Patricia Campbell BA, 1995.** On Aseptic Loosening in Total Hip Replacement: the role of polyethylene wear debris. Thesis defended 7.2.1995.
14. **Ann Wennerberg DDS, 1996.** On Surface Roughness and Implant Incorporation. Thesis defended 19.4.1996.
15. **Neil Meredith BDS MSc FDS RCS, 1997.** On the Clinical Measurement of Implant Stability and Osseointegration. Thesis defended 3.6.1997.
16. **Lars Rasmusson DDS, 1998.** On Implant Integration in Membrane Induced and Grafted Bone. Thesis defended 4.12.1998.
17. **Thay Q Lee MSc, 1999.** On the Biomechanics of the Patellofemoral Joint and Patellar Resurfacing in Total Knee Arthroplasty. To be defended 19.4.1999.
18. **AnnaKarin Lundgren DDS, 1999.** On Factors Influencing Guided Regeneration and Augmentation of Intramembraneous Bone. Thesis defended 7.5.1999.
19. **Carl-Johan Ivanoff DDS, 1999.** On Surgical and Implant Related Factors Influencing Integration and Function of Titanium Implants. Experimental and Clinical Aspects. Thesis defended 12.5.1999.
20. **Bertil Friberg DDS, MDS, 1999.** On Bone Quality and Implant Stability Measurements. Thesis to be defended 12.11.1999.
21. **Åse Allansdotter Johnsson, MD, 1999.** On Implant Integration in Irradiated Bone. An Experimental Study of the Effects of Hyperbaric Oxygenation and Delayed Implant Placement. Thesis to be defended 8.12.1999

ABSTRACT

In conjunction with placement of oral implants the jaw bone quality assessment is mainly based on quantitative radiographic measures and the subjective opinion of the performing surgeon. While the primary implant stability is discussed in terms of the pre-set motor torque and the subjective hand-felt perception during final tightening of implants, the secondary stability is defined as the absence of implant mobility. The objectives of the present thesis were to evaluate the technique of true cutting resistance, designed to define and objectively measure the bone quality or bone hardness, with regard to its reliability and applicability to the clinical situation. Correlation analyses were performed between values of cutting resistance and bone density, as well as between cutting resistance and total bone area of maxillae and mandibles. Further, the resonance frequency technique was utilized, aiming at objectively measure the obtained primary and secondary implant stabilities in maxillae and mandibles. Correlation analyses were performed between values of cutting torque and resonance frequency. The one-stage surgical protocol was executed in mandibles for repeated stability measurements during healing. Implants placed according to the two-stage surgical protocol, using the standard and an adapted preparation technique with extended healing periods, were compared with regard to various failure patterns.

The true cutting resistance technique was found reliable and applicable to the clinical situation, and significant correlations were demonstrated between the measured bone density and total bone area, respectively, and values of cutting resistance. Significantly more total bone, i.e. mainly compact bone, was seen in mandibles as compared to maxillae and values of cutting resistance were significantly higher in mandibles. No lower limit value at which implants were at risk was possible to identify, since cutting torque values were similar for successful and failed implants. Implant stability, as measured with resonance frequency, increased more in bone of low density than in bone of medium or high density during healing and initial loading periods. A significant correlation between the values of cutting torque of the crestal bone and resonance frequency was observed. While the implant outcome was favourable using the one-stage protocol and no increase in stability was demonstrated for implants placed in the anterior mandible, a concept of one-stage surgery and direct loading may be recommended for implants inserted in similar bone texture. The early failure rate was found equal (1.5%) for the two separately conducted two-stage surgical approaches, and implants in maxillae failed to a higher extent than mandibular ones. When using a standard treatment protocol, limited bone volume and poor bone texture were major determinants for early failures. When using an adapted preparation technique and extended healing, no such early failure patterns were seen. With regard to late failures, implants placed in maxillary bone of limited volume still represented more failures, while no such finding was demonstrated in bone of poor texture. Thus, early and late implant failure rates were equally low in bone of poor texture, when using the adapted surgical technique.

Keywords: early failures, titanium implants, jaw bone quality, jaw bone volume, cutting torque, implant stability, resonance frequency, one-stage surgery,

ISBN 91-628-3863-6

Correspondence: Dr Bertil Friberg, Department of Biomaterials/Handicap Research, Institute for Surgical Sciences, Göteborg University, PO Box 412, SE 405 30 Göteborg, Sweden

LIST OF PAPERS

This thesis is based on the following papers which will be referred to in the text by their Roman numerals:

- I. **Friberg B, Jemt T, Lekholm U.** Early failures in 4,641 consecutively placed Brånemark dental implants: A study from stage 1 surgery to the connection of completed prostheses.
Int J Oral Maxillofac Impl 1991; 6: 142-146.
- II. **Friberg B, Sennerby L, Roos J, Johansson P, Strid K-G, Lekholm U.** Evaluation of bone density using cutting resistance measurements and microradiography. An in vitro study in pig ribs.
Clin Oral Impl Res 1995; 6: 164-171.
- III. **Friberg B, Sennerby L, Roos J, Lekholm U.** Identification of bone quality in conjunction with insertion of titanium implants. A pilot study in jaw autopsy specimens.
Clin Oral Impl Res 1995; 6: 213-219.
- IV. **Friberg B, Sennerby L, Gröndahl K, Bergström C, Bäck T, Lekholm U.** On cutting torque measurements during implant placement. A 3-year clinical prospective study.
Clin Impl Dent Rel Res 1999; in press.
- V. **Friberg B, Sennerby L, Meredith N, Lekholm U.** A comparison between cutting torque and resonance frequency measurements of maxillary implants. A 20-month clinical study.
Int J Oral Maxillofac Surg 1999; 28: 297-303.
- VI. **Friberg B, Sennerby L, Lindén B, Gröndahl K, Lekholm U.** Stability measurements of one-stage Brånemark implants during healing in mandibles. A clinical resonance frequency analysis study.
Int J Oral Maxillofac Surg 1999; 28: 266-272.

CONTENTS

INTRODUCTION	7
General remarks on oral implant success and failure	7
Load-related jaw bone changes	8
BONE VOLUME	9
Age-related changes of external and internal jaw bone dimensions	9
Means to improve the bone volume	10
BONE QUALITY	13
Age-related changes of internal jaw bone structures	13
Definitions of the term bone quality	14
Techniques for jaw bone quality measurements	14
General remarks on bone quality identifying techniques	20
Means to maintain/improve the bone quality	20
IMPLANT STABILITY	22
Implant stability and bone quality	22
Non-invasive techniques for implant stability measurements	23
Implant stability and duration of healing	26
One- versus two-stage techniques/delayed versus immediate loading	27
General remarks on literature review	29
AIMS	31
MATERIALS AND METHODS	32
Experimental studies (II, III)	32
Clinical studies (I, IV-VI)	37
RESULTS	46
Experimental studies (II, III)	46
Clinical studies (I, IV-VI)	49
DISCUSSION	55
Methodological considerations	55
Cutting torque and bone density measurements	57
Implants and bone quality	59
Implants and bone volume	61
General remarks on implant results	62
Cutting torque and resonance frequency measurements	64
Implant stability and duration of healing	65
Resonance frequency and marginal bone level changes	66
Resonance frequency as a diagnostic aid	67
One stage surgery/delayed or immediate loading	68
CONCLUSIONS	70
CLINICAL IMPLICATIONS	72
ACKNOWLEDGEMENTS	74
REFERENCES	75

- 1 This the ...
- 2 ...
- 3 ...
- 4 ...
- 5 ...
- 6 ...
- 7 ...
- 8 ...
- 9 ...
- 10 ...
- 11 ...
- 12 ...
- 13 ...
- 14 ...
- 15 ...
- 16 ...
- 17 ...
- 18 ...
- 19 ...
- 20 ...
- 21 ...
- 22 ...
- 23 ...
- 24 ...
- 25 ...
- 26 ...
- 27 ...
- 28 ...
- 29 ...
- 30 ...
- 31 ...
- 32 ...
- 33 ...
- 34 ...
- 35 ...
- 36 ...
- 37 ...
- 38 ...
- 39 ...
- 40 ...
- 41 ...
- 42 ...
- 43 ...
- 44 ...
- 45 ...
- 46 ...
- 47 ...
- 48 ...
- 49 ...
- 50 ...
- 51 ...
- 52 ...
- 53 ...
- 54 ...
- 55 ...
- 56 ...
- 57 ...
- 58 ...
- 59 ...
- 60 ...
- 61 ...
- 62 ...
- 63 ...
- 64 ...
- 65 ...
- 66 ...
- 67 ...
- 68 ...
- 69 ...
- 70 ...
- 71 ...
- 72 ...
- 73 ...
- 74 ...
- 75 ...
- 76 ...
- 77 ...
- 78 ...
- 79 ...
- 80 ...
- 81 ...
- 82 ...
- 83 ...
- 84 ...
- 85 ...
- 86 ...
- 87 ...
- 88 ...
- 89 ...
- 90 ...
- 91 ...
- 92 ...
- 93 ...
- 94 ...
- 95 ...
- 96 ...
- 97 ...
- 98 ...
- 99 ...
- 100 ...

INTRODUCTION

General remarks on oral implant success and failure

Osseointegrated oral implants, as originally defined by Brånemark (Brånemark et al 1977), have been extensively used around the world. Apart from the well defined Brånemark System[®], also other oral implant systems have been documented, such as e.g. ITI and Astra (Åstrand et al 1996a, Buser et al 1997, Palmer et al 1997, Arvidsson et al 1998, Åstrand et al 1999). Regarding the Brånemark System[®], a series of reports have thoroughly evaluated its long-term results with implant survival in the magnitude of 82-99% after up to 10 years of loading (Cox & Zarb 1987, van Steenberghe et al 1987, Albrektsson 1988, Adell et al 1990, Bahat 1993, Jemt & Pettersson 1993, Nevins & Langer 1993, Eckert & Wollan 1998, Wyatt & Zarb 1998). Similar results were obtained in 5-10 year prospective multicenter studies, executed for different jaw situations (Lekholm et al 1994, Henry et al 1996, Jemt et al 1996, Friberg et al 1997, Lekholm et al 1999a). Despite a meritorious treatment outcome, problems and complications have been encountered when wielding the procedure (Lekholm 1985a, Worthington et al 1987, Engquist et al 1988, Zarb & Schmitt 1990, Jaffin & Berman 1991, Jemt 1991, Sennerby 1991, van Steenberghe 1991, Jemt & Lekholm 1995, Bryant 1998). In extensive literature reviews conducted by Esposito et al (1998a+b), the epidemiology and etiopathogenesis of biological factors contributing to implant failures have been scrutinized. Using a metanalytic approach comprising a sample of 2,812 implants (Brånemark System[®]), the biologically related implant failure rate over a 5-year period was found to be 7.7% (Esposito et al 1998a). The early failure rate, i.e. the percentage of implants for which osseointegration was never established due to an interference with the healing process, was calculated from a bigger sample (16,935 implants) and accounted for 3.6%. Implants in partially edentulous patients performed better than implants in patients with complete edentulism, and in the latter group implant losses were almost three times as frequent in maxillae as compared to mandibles. It was suggested that surgical trauma together with anatomical conditions were predominant factors for early failures, while peri-implantitis was rarely seen with the Brånemark System[®], either as an early or late failure. Overload together with insufficient bone volume and deficient bone quality were suggested as the three major determinants for late failures (Esposito et al 1998a).

Load-related jaw bone changes

With regard to excessive load, several reports are available on its influence on bone resorption and implant failure. In a review paper by Brunski (1992) it was stated that interfacial stresses and strains from loading could endanger the implant surrounding tissues, resulting in increased bone resorption and/or implant loss. The magnitude of stresses and strains in the interface depended on many factors of which the quantity and quality of bone were mentioned. Since load divided by supporting area was considered to be an estimate of the interfacial stress magnitude, the amount of bone present to support the implant, as well as the mechanical properties of the bone in implant contact, were said to influence the outcome in terms of implant success versus implant failure. Excessive marginal bone loss (>1 mm) after the first year of loading was shown in patients who were exposed to overload, due to the presence of parafunctional activity, lack of anterior contacts and osseointegrated full fixed prostheses in both jaws (Quirynen et al 1992). In a dog model, titanium implants were subjected to a controlled loading protocol (Hoshaw et al 1994). As compared to controls, trends towards increased bone resorption around the implant neck as well as decreased percentage of mineralized tissue in the cortex close to the loaded implants were demonstrated. The authors concluded that the bone resorption was overload-related and a consequence of bone modeling and remodeling triggered by damage in the supporting interfacial bone. Isidor (1996) compared the breakdown of bone around oral implants following excessive occlusal load and plaque accumulation in monkeys. A unilateral mandibular implant-supported construction was designed to result in a lateral, rather than axial excessive occlusal load. The remaining mandibular implants were kept out of occlusion and exposed to cotton cords and plaque accumulation. The majority of the overloaded implants (5/8) lost osseointegration, while none of the implants with plaque accumulation (0/12) were lost. Based on the outcome, the author suggested that, while plaque accumulation resulted in loss of marginal bone height, occlusal overload could be a main factor for the loss of osseointegrated implants. Using a finite element model, stress and strain distributions around a solitary Brånemark implant were studied (Van Oosterwyck et al 1998). The authors suggested that if marginal bone loss was caused by excessive lateral forces, a bicortical anchorage of the implant would not reduce the risk for bone resorption, while the presence of a lamina dura would prevent local overload. In a similar study, Clelland and coworkers (1993) showed the

influence of crestal cortical thickness on stresses in the crestal region. By doubling the thickness of the cortical shell, resultant stresses decreased more than 50%. In a pilot study in rabbits, Jemt & Lekholm (1998) measured the distortion of implant frameworks and bone surrounding osseointegrated implants from static load due to superstructure misfit. They found bone deformation in close connection to the implants and underneath the framework and that this deformation might be either an increased or decreased bone volume. It was also demonstrated that both the framework and the bone could flex more than 100 microns. The authors speculated on this deformation to be important for the initial bone remodeling. Control of implant load factors in the posterior partially edentulous segment was reviewed by Rangert et al (1997). A number of factors were discussed to be decisive for the short- and long-term implant outcomes, such as the type and magnitude of load, implant design, implant position and number, the mechanical properties of implant and interfacial tissue, prosthesis design, technological risk factors (e.g prosthesis misfit) and the quantity and quality of the bone.

From a surgical perspective, both pre- and peroperative evaluations of the jaw bone characteristics are needed. Gathered information should be used in order to adapt the surgical technique as well as the length of the healing period to the current bone situation, thereby minimizing the number of complications.

BONE VOLUME

Age-related changes of external and internal jaw bone dimensions

The mandibular anterior residual ridge form has been described in six orders by Atwood (1963,1971a), such as high well-rounded, knife-edged, low well-rounded and depressed. The average rate of reduction of the residual ridge (RRR) in mandibles (0.4 mm/year) was found to be four times that of the maxilla (Atwood & Coy 1971b). This relationship between RRR of mandibles and maxillae was later confirmed by Tallgren (1972), who conducted a longitudinal study on edentulous patients. In the paper by Atwood (1971a), three factors were suggested to influence the RRR; i.e. anatomic (size and shape, type of bone), metabolic (age, sex, hormonal balance, osteoporosis) and mechanical (frequency, direction and amount of force applied to the ridge, type of denture base,

interocclusal distance, etc) ones, respectively. It was also stated that while resorption occurred externally, new bone was laid down internally to preserve a certain thickness of the cortical bone. This was consistent with observations made by Ulm et al (1992), who found a coarsening of the cancellous structure and the development of "compact islands" as a compensation for the bone loss caused by external atrophy. Cawood & Howell (1988) proposed six shape classes of atrophic maxillae and mandibles and found the alveolar bone resorption to follow a predictable pattern. Anterior maxillae and mandibles, as well as posterior maxillae showed vertical and horizontal (from the labial/buccal aspect) bone loss, whereas the bone loss in posterior mandibles was mainly vertical.

The age-related changes of the maxillary sinus have been extensively described by Watzek et al (in Jensen 1999). In brief, the sinus walls may gradually become thinner after extraction of maxillary teeth and the reduction of masticatory forces acting on the maxilla. The alveolar recesses will sometimes extend to the edentulous alveolar ridge, and in extreme cases after long-term edentulism, only a paper-thin lamella of bone may separate the sinus from the oral cavity. Anteriorly, the sinus may extend to the alveolus of the canine tooth and posteriorly it occasionally fills out the maxillary tuberosity. The antral pneumatization of the alveolar process is assumed to result from the basal bone loss caused by the reinforcement of osteoclastic activity of the schneiderian membrane.

Means to improve the bone volume

Numerous reports on bone augmentation procedures are available, using various techniques with autogenous bone grafts as onlays and/or inlays together with titanium implants, to restore local, as well as substantial defects in maxillae and mandibles (Breine & Brånemark 1980, Kahnberg et al 1989, Adell et al 1990, Jensen & Sindet-Pedersen 1991, Nyström et al 1993, Isaksson 1994, Krekmanov 1995, Tolman 1995, Blomqvist et al 1996, Triplett & Schow 1996, Williamson 1996, Åstrand et al 1996b, Lekholm et al 1999b). In a 3-year retrospective multicenter study, comprising 23 Scandinavian clinical centers, Lekholm et al (1999b) demonstrated an overall implant survival rate of 80%, when combining the results of various techniques. Although, a one-stage procedure, ie graft and implants are placed simultaneously, was suggested by Breine & Brånemark (1980), lately there has been a general trend to use a two-stage procedure (delayed), in which implants are inserted 5-6 months after the grafting. The results after 6 months to

5 years of loading ranged roughly between 70 and 95% independent of technique used (for review, see Tolman 1995). While some reports have been in favour of simultaneous implant placement or have shown similar results with the two techniques (Keller et al 1987, Donovan 1994, Blomqvist 1998), an improved outcome with the delayed technique has been reported by others (Triplett & Schow 1996, Jensen et al 1998, Lekholm et al 1999b). In a histological analysis of microimplants by Lundgren et al (1998), comparing simultaneous and delayed implant placement, significant more bone-implant contact and bone area within implant threads were demonstrated 12 months post grafting with the delayed technique. Rasmusson et al (1999a) found significantly higher implant stability, as measured at five occasions with resonance frequency, for implants placed with the delayed compared to the simultaneous approach. Furthermore, the two-stage technique has been found to offer the surgeon more optimal conditions for positioning of implants (Blomqvist et al 1997).

The report of the Sinus Consensus Conference in Wellesly, Massachusetts, USA (1996) stated that the sinus graft, augmenting an expanded maxillary sinus, should be considered a highly predictable and therapeutic modality (Jensen et al 1998). Complete data from 38 surgeons, executing 1007 sinus grafts that involved the placement of 2997 implants over a 10-year period (the majority of the implants followed for 3 years), demonstrated an implant success rate of 90%. This figure was obtained independently of graft materials and implant surfaces used. The results with combinations of allografts (mineralized, demineralized, frozen irradiated bone), xenografts (mainly bovine bone) and alloplasts (dense and porous hydroxyapatite, tricalcium phosphate) rendered an implant survival rate after 3 years of 97.6%! These overly optimistic data were, however, not presented in a scientific manner at the meeting and the true outcome must be regarded as uncertain (Albrektsson 1999, personal communication). Furthermore, no information was given regarding the amount of residual bone that was present at the time of grafting.

The use of allografts remains a matter of controversy. Urist (1965) isolated bone morphogenetic protein (BMP) from demineralized bone matrix and found it to induce ectopic bone formation. His pioneering study has served as a base for the use of demineralized freeze-dried bone allografts (DFDBA) in periodontal defects and in relation to placement of dental implants (Mellonig et al 1976, Quintero et al 1982, Nevins &

Mellonig 1992, Cortellini & Bowers 1995). However, in a series of publications Becker et al (1994,1995,1996), when using DFDBA in mice as well as in humans, questioned the ability of DFDBA to induce new bone formation and found little or no evidence of osteoclastic resorption of the implanted bone. This is in accordance with studies by Pinholt et al (1992, 1994), who failed to show osteoinduction capacity of DFDBA particles and found titanium implants inserted in DFDBA-reconstructed defects to heal with fibrous encapsulation. The need for a demineralized bone matrix supplemented with recombinant human BMP was pointed out by Becker et al (1995), which was later tested by Schwartz et al (1998). They implanted batches with active and inactive DFDBA and batches with inactive DFDBA supplemented with recombinant BMP into mice muscles. A significant increase in bone induction score was seen with the BMP-supplemented DFDBA and the resorption rate seemed to be BMP dose-dependent. It was suggested that some commercial preparations of DFDBA were inactive with regard to bone induction ability, because of lack of adequate quantities of BMP. A positive effect of growth factor bone augmentation procedures was reported by Boyne et al (1997), who implanted human recombinant BMP-2 delivered on a carrier other than DFDBA (absorbable collagen sponge) into the sinus floor of 12 patients. The overall mean height response for the maxillary sinus floor augmentation was > 8 mm, and 11 of the 12 patients received oral implants 16 weeks later without additional bone grafting procedures.

Guided bone regeneration (GBR) with barrier membranes have been utilized for the guidance of bone cells into minor bone defects (for review, see Buser et al 1994), with the principle to exclude tissue cells others than those with osteogenic properties. Although problems have been associated with its use, such as collapse of the barrier, soft tissue ingrowth and incomplete bone fill, mucosal perforation and infection, encouraging results have been reported with guided bone regeneration or guided bone augmentation within, as well as beyond the skeletal envelope (for review, see Rasmusson 1998a, Lundgren 1999).

The technique of new bone generation by stretching, distraction osteogenesis, was first described by Ilizarov (1989a+b). With fixator stability and maximum preservation of periosteum and bone marrow, it was possible to form bone during limb lengthening. The use of distraction osteogenesis together with oral implants has been reported (Block et al 1998, Oda et al 1999, Urbani et al 1999). In the study by Oda et al (1999), implants

were inserted with the upper half exposed in partly mobilized alveolar bone segments, which were thereafter fully mobilized. By turning the implant 1.5 times daily (i.e. 0.9 mm), the alveolar bone was vertically augmented 5 mm in 6 days. Some bone resorption and loss of implants were reported.

BONE QUALITY

Age-related changes of internal jaw bone structures

Numerous studies have been executed to describe the edentate jaw region with regard to anatomy and age-related changes of inner bone dimensions in presumptive implant regions. Through mapping of edentate and partially edentate mandibles, extreme variations in trabecular bone volume and connectedness were revealed within as well as between jaws (von Wowern 1977a, Lindh et al 1996a, 1997, Ulm et al 1997). Increased trabecular bone density was frequently seen in anterior compared to posterior regions (von Wowern 1977a, Lindh et al 1996a). While the buccal cortex varied in density throughout the mandible, the lingual cortex was found to be more uniform and independent of the state of dentition (von Wowern, 1977b). It was shown, however, that the bone mineral density (BMD) of both cortices distal to the mental foramina was influenced by the functional stresses exerted by the masticatory muscles after extraction (Klemetti et al 1994a), and a strong positive correlation was found between the size of the masseter muscle and the cortical BMD (Klemetti et al 1994b). Both cortices showed increasing porosity with age (von Wowern & Stoltze 1978), although contradictory results have been reported with regard to the relationship between the inferior cortical shape and width versus patient's age and state of osteoporosis (Kribbs et al 1990, Benson et al 1991, Klemetti et al 1993a, Klemetti et al 1994c, Watson et al 1995, Taguchi et al 1995, Taguchi et al 1996, Ledgerton et al 1997, Klemetti & Kolmakow 1997, Horner & Devlin 1998a+b). In edentulous maxillae, Razavi et al (1995) found histologically an increased trabeculation and thicker cortex in the anterior area as compared to the posterior ones, while the tuberosity region consisted of fatty marrow, increased connective tissue content and only clusters of bone with trabeculation. Even though these reports tend to characterize the jaw bone, very little is said about the bone quality per se. The latter may

not be expressed without a certain amount of subjectivity, and the opinion will mainly be based on quantitative measures. Far more information may be obtained from the literature of osteoporosis and bone biomechanics (Chamay & Tschantz 1972, Reilly & Burstein 1974, Grynypas & Holmyard 1988, Compston 1990, Melton 1990, Brunski 1992, Lockington & Bennett 1994, Hans et al 1997).

Definitions of the term bone quality

Horner & Devlin (1998a) claimed that the bone quality referred to various factors such as BMD, the cortical thickness, as well as trabecular density and thickness. According to Alhava (1991), however, BMD only related to the mineral content and not to bone quality, while Stulberg et al (1989) found the cortical and trabecular density and thickness to reflect the volume of bone. The latter authors stressed that there were two important quality factors, i.e. the ability to adapt to specific loads and the capability to remodel. The quality has also been related to the mechanical properties of bone and especially to its strength and stiffness (Martin 1991), which were said to be influenced by the external and internal shape and size, as well as by the biomechanical properties of the material within. Einhorn (in Wallach et al 1992) described the quality via parameters, measuring the mechanical properties of bone under load, such as elastic modulus, stiffness, strength and strain. Hayes (in Wallach et al 1992), however, found few data to support a relationship between these mechanical properties and typical quality characteristics related to various aspects of bone morphology, such as microdamage, trabecular dimensions and contiguity, as well as to the state of mineralization.

In the absence of a clear definition of bone quality a more practical definition could be to rate the bone hardness, experienced during drilling of implant sites. Such a subjective opinion would be dependent on the state of mineralization, the coarseness and contiguity of the trabecular bone and the width of the cortical layers and thus correlated to the experience of the performing surgeon.

Techniques for jaw bone quality measurements

In the treatment planning for oral implants, a **radiographic examination** comprising intraoral and panoramic radiographs, lateral cephalograms and tomographic images have been suggested (Gröndahl et al 1996). Conventional tomograms (Eckerdal

& Kvint 1986, Gröndahl et al 1991, Tammisalo et al 1992, Grönahl et al 1996) or images obtained with a computed technique (Andersson & Svartz 1988, Quirynen et al 1990, Matteson et al 1996) are mainly required when investigating the maxilla and the posterior mandible. Taken together, the radiographs may yield extensive information of anatomical characteristics, such as the structures of the nasal cavity, the incisive canal, the sinuses, the mandibular canal and the mental foramina. Along with these landmarks, the images offer possibilities to describe the jaws with regard to volume and composition of compact and cancellous bone, as well as in terms of pathology. Lekholm & Zarb (1985b) proposed a jaw bone classification by rating the quality from 1 to 4, depending on the amount of compact and cancellous bone present. In quality 1, compact bone predominated the jaw, while in quality 4 mainly cancellous, osteoporosis-like bone was at hand. Together with explorative drilling of implant sites, a more complete but still subjective picture of the bone quality was obtained, although only a rough mean value was presented of each examined jaw. Jensen (1989) suggested a classification of individual bone sites, based on radiographic as well as on clinical parameters such as vital structure proximity, orthodontic malocclusion, general or local disease or disorder, etc. A density index with four classes (D1-D4), based on the classification by Lekholm & Zarb (1985b), was presented by Misch (1990), however, the Jensen and Misch indices have not been in common use. A more recent index was proposed by Lindh et al (1996b) for planning, performance and prognosis of implant treatment. Three classes of trabeculation were discerned by assessing the mandibular trabecular pattern in periapical radiographs.

When planning for oral implants the subsequent treatment will mainly be based on the information obtained from the radiographic examination. With regard to the quality classification by Lekholm & Zarb (1985b), the assessed radiographs provide for quantitative information only, since they describe the cortical width and the density of the trabecular bone pattern present. Only one value is given for the entire jaw, which is based on the personal experience and the subjective opinion of the surgeon.

In **quantitative computed tomography (QCT)**, the bone quality was assessed by a density value in Hounsfield units (HU), which was assigned each picture element (pixel) of the computer calculated image (Andersson & Kurol 1987, Berman 1989, Duckmanton et al 1994, Matteson et al 1996, Lindh et al 1996a). A value of -1000 HU corresponded to air, 0 HU to water and +1000 HU represented bone. The obtained

numbered units of the bone might serve as an indicator of the resistance to be anticipated during drilling. A major advantage with QCT compared to other techniques is its ability to isolate and measure trabecular and cortical bone separately (Taguchi et al 1991, Klemetti et al 1993b, Dougherty 1996, Matteson et al 1996, Lindh et al 1996a). In the treatment planning this may be important, since most implants will be inserted in, and come in contact with, both cortical and cancellous bone. Cancellous bone with densitometric readings of less than +100 HU was considered poor quality with little ability of the bone to provide primary stability for the implant (Duckmanton et al 1994). Computed tomography scans have been used to generate three-dimensional solid models of scanned objects. Bill et al (1995) reconstructed alveolar ridge defects using stereolithography, and advocated that the method improved pre-operative treatment planning.

Although, many CT scanners can produce the bone density in HU, few studies have reported on its use together with oral implants. The disadvantages of the method were described as relatively high radiation dose, high cost and long time of image acquisition (Matteson et al 1996).

The utility of **bone mineral density (BMD)** measurements of mainly axial and appendicular skeleton (lumbar spine and proximal femur) has been reported in numerous studies, using ionizing beams from either isotopes or X-ray tubes (apart from QCT) to predict the risk of future fractures in osteoporosis. The BMD was found to explain about 70-75% of the variance in bone strength (Hans et al 1997), but a substantial overlap in BMD between osteoporotic and non-osteoporotic populations was also reported (Dougherty 1996, Sturtridge et al 1996, Hailey et al 1998). In a complex tissue like bone, density measurements were not considered sufficient for determining the strength and the fracture risk (Alhava 1991, Greenfield 1992). Cumulative and synergistic effects of other factors, such as accumulated burden of fatigue damage, ineffective bone architecture; i.e the three-dimensional arrangement of trabecular struts and state of remodeling were, as well, related to the predisposal for bone fractures (Hans et al 1997).

von Wowern (1988) used dual energy photon absorptiometry (DPA) to examine the in vivo relationship of bone mineral content (BMC) of mandibles, forearms and lumbar spine. A significant correlation of BMC was found between forearms and lumbar spine, but no corresponding relationship with these regions and the mandible could be seen. The conclusion was that BMC changes of mandibles could only be evaluated by

investigations of the mandible itself. In a more recent study Klemetti et al (1993a) reported that the mandibular cortical BMD was clearly correlated with the lumbar spine and femoral neck BMD, while the mandibular trabecular BMD was not. Age-related changes of cortical BMD of mandibles have been reported (Klemetti et al 1993c), while trabecular BMD seemed to be independent of age (von Wowern & Stoltze 1978, Klemetti et al 1993a). In relation to treatment with osseointegrated ITI-implants supporting overdentures (von Wowern et al 1990), BMC was measured with DPA in different mandibular regions, 3 weeks and 2 years postoperatively. The authors concluded that the implant treatment caused a load-related bone formation, which could minimize, or even counteract, the physiologic age-related BMC loss seen in osteoporosis. This increase in bone density around implants with several years of function was reported earlier by Strid (1985). A bone preserving effect of fixed implant-supported prostheses in mandibles, when compared to removable dentures, was also shown by Sennerby et al (1988). The use of dual energy X-ray absorptiometry (DXA) measurements of the mandible in four patients was first reported by Corten et al (1993). Horner & Devlin (1998a) found significant correlations between the bone quality index (Lekholm & Zarb 1985b) and BMD of the mandibular body as measured with DXA, as well as between the mandibular cortical index (Klemetti et al 1994c) and BMD. In the effort of detecting periimplant bone changes in mandibles *ex vivo* with DXA, Denissen et al (1996) reported a high precision and the possibility to detect changes in BMD as small as 0.85%. A drawback with the instrument was, however, that the X-ray beam first hit one half of the mandible or maxilla and then the other. Remaining teeth were found to produce shadows on the DXA scans, which probably led to an artificially high BMD value (Horner & Devlin 1998a).

DPA- and DXA-techniques have had limited use in jaw bone diagnostics for implant treatment. Even though the BMD is a quantitative measure (Alhava 1991, Greenfield 1992), it is regarded to have a relationship with compressive strength and elastic modulus of bone (Martin 1991), both being looked upon as quality parameters (Einhorn, in Wallach et al 1992).

The non-invasive method of measuring **ultrasound attenuation and velocity** in heel bone and forearm has been claimed possible to use for bone quality determination (Greenfield 1992, Antich et al 1993). Correlations between parameters of ultrasound and BMD have been found (Hans et al 1997), and according to Jonson (1994), the ultrasound

velocity is influenced by the orientation of the trabeculae. It is also dependent on the modulus of elasticity and the bone density (Buckingham et al 1992, Antich et al 1993). Only few studies have reported or addressed the usefulness of ultrasound to monitor the treatment of osteoporosis, and measurements of skeletal changes by means of only ultrasound have, as yet, not been recommended (Hans et al 1997).

Little information is available regarding the use of ultrasound for evaluation of the jaw bone characteristics. Sonographic measurements of the alveolar bone topography and width in the assessment of periodontal bone morphology and when planning for oral implants have been performed with mixed results (Palou et al 1987, Traxler et al 1992).

The utilization of **fractal analysis** of objects, appearing statistically similar over a range of scales and not exhibiting any smooth surfaces (e.g. trabecular bone), has been explored during the last decade. Thereby, the characteristic fractal dimension associated with such objects has been calculated, using extensive and complex computational algorithms. Based on photomicrographs of iliac crest biopsies, fractal analysis was found useful in distinguishing osteoporotic bone structure from normal (Majumdar et al 1993). Based on mandibular radiographs obtained from post-menopausal women, calculated fractal dimensions were markedly different from those obtained from pre-menopausal women, indicating an onset of osteoporosis (Doyle et al 1990). Similar findings were reported by Law et al (1996), who compared four methods regarding their ability to detect osteoporosis from dental radiographs. Fractal dimension, as being one of the methods, was found effective, though not the best, for the purpose. Fractal analysis has also been used to reveal remodeling in human alveolar bone following placement of oral implants (Wilding et al 1995).

The use of **magnetic resonance imaging (MRI)** as a tool for evaluation of bone prior to implant surgery has been reported (Zabalegui et al 1990, Hirschmann 1998). It was stated that MRI gave information of the three-dimensional relationship of vital structures without using ionizing beams and should be considered as an alternative to computed tomography (Hirschmann 1998). The same author claimed that full sectional detail of available bone for safe implant placement was at hand. However, unlike CT, the MRI signal does not originate from the mineral content of bone, and thus bone quality estimation is problematic.

With regard to ferromagnetic properties of already inserted Brånemark implants,

Devge et al (1997) found that the implants were not influenced when exposed to MRI, and that the artifacts caused by the implants were minor without jeopardizing the evaluation of the scans.

Jaw **bone biopsies** may be used for morphology evaluation. However, due to the invasive character of the procedure, it does not seem practical to obtain a bone sample from every patient preoperatively. Klinge et al (1995) proposed the use of bone biopsies at the time of mandibular implant site preparation for subsequent histomorphometric analysis. Based on an objective quality score, expressed in terms of bone area, they suggested an individualized healing period after implant placement. The amount of bone varied considerably between individuals and in different locations of the same jaw, findings being in accordance with other reports (von Wowern 1977a+b, Lindh et al 1997, Ulm et al 1997). Thus, the clinical use of such a procedure may be limited, since a biopsy must be harvested from each implant site. Trisi & Rao (1999) utilized bone biopsies, obtained during oral implant surgery in a similar way as performed by Klinge et al (1995), for histomorphometric evaluation. The percentage of bony trabeculae over the total biopsy area was correlated with the bone scoring recorded during drilling of the implant bed, based on the hand-felt perception of the drilling resistance (Misch 1990). They demonstrated that the hand feeling allowed to distinguish, with statistically significant confidence, D1 and D4 bone, but failed to separate the intermediate classes of bone quality.

A method to measure the **true cutting resistance** during low speed threading of implant sites has been introduced (Johansson & Strid 1994) as a technique for evaluation of bone quality. The consumed electric current was registered during low speed threading by a motor unit-connected computer, which determined the total torque used. Via computer calculation procedures, it was possible to subtract the friction part of the torque, as well as the contribution of bone shiver packing in deeper holes. The true cutting resistance, corresponding to the remaining part of the torque and measured in mJ/mm³, was said to express the bone quality in terms of "energy needed to cut out a specific amount of bone material with the tool". In the same study, test slabs of bovine bone were radiographed in areas where holes were threaded and measured. These radiographs were assessed, using an aluminum-reference to identify the density, and a good agreement was found between values of the true cutting resistance and of the aluminum-referred density. The latter is in agreement with the report by Sugaya (1990) and Friberg (1994a), who found

a correlation between bone density and the cutting torque registered during drilling in autopsy specimens.

General remarks on bone quality identifying techniques

In the absence of a clear definition of bone quality, it may be difficult to fully value the methods available for bone quality investigation. The aforementioned techniques mainly express the bone characteristics in quantity measures, either by rating the bone structures obtained from radiographs and histomorphometry, or by analysing the bone mineral content. Nevertheless, the encouraging results of the technique proposed by Johansson & Strid (1994) may open for clinical possibilities to obtain an objective measure, expressing the bone quality in terms of bone hardness in each individual site.

Means to maintain/improve the bone quality

In the treatment of osteoporosis and prevention of fractures daily administrations of calcium, vitamin D and hormone replacement therapy (HRT) with estrogen have shown effects (Compston 1990, Marcus 1996, Läkemedelsverket 1:97, Jeffcoat 1998). In a long-term evaluation, Jacobs et al (1996) reported on the positive influence of HRT also on the mandibular bone mass, as measured with DPA. Alendronate, which is a synthetic bisphosphonate reducing osteoclast number and activity, was found, when given daily for 2 years, to increase BMD of the lumbar spine, femur neck and the total body (McClung et al 1998). Another report of the same study showed reduced risks for new vertebral and hip fractures by about 50% and for all clinical fractures by about 30% (Adachi 1998). Depending on dosage, bisphosphonates could, however, reduce bone turnover in dogs to nearly zero (Flora et al 1980), which allowed virtually no repair of microdamage that accumulated as a result of normal activity. Inability of the bone remodeling response to mechanical stimuli may have been a decisive factor for the outcome of failed mandibular osseointegrated implants in a patient treated with osteoclast inhibitors (Starck & Epker 1995). Fluorides are potential stimulators of osteoblast activity and increase BMD. According to Läkemedelsverket (1:97), several studies have shown abnormal histology after long-term treatment with fluorides, but it may have been a matter of dosage. Antich et al (1993) found significantly lower spinal fracture rate after 2 years of treatment with slow-release sodium fluoride and calcium citrate.

The use of growth factors as bone inducing agents together with oral implant treatment has met great interest during later years. A combination of platelet derived growth factors (PDGF) and insulin-like growth factors (IGF-1) was used in dogs and an accelerated bone formation, as well as greater percentage of bone fill in peri-implant spaces were demonstrated, as compared to controls (Lynch et al 1991, Becker et al 1992). Bovine bone morphogenetic protein (BMP) was utilized together with titanium implants placed in monkeys or dogs and an accelerated bone formation was seen (Rutherford et al 1992, Yan J et al 1994, Bessho et al 1999). Smith (1995) placed titanium implants together with human recombinant transforming growth factor beta (TGF- β) into extraction sockets of minipigs and found an enhanced percentage of osseointegration but failed to show any acceleration of implant integration. In humans, bovine BMP was applied in compromised surgical reconstructions (bone defects, grafts, and infections) in relation to titanium implant placement (Sailer & Kolb 1994). It was demonstrated that BMP could induce bone even in areas with seemingly lost implants. Marx and coworkers (1998) obtained platelet-rich plasma (PRP), as an autologous source of PDGF and TGF- β . This was accomplished simultaneously with a bone harvesting procedure and did not add to the operating room time. They showed a radiographic graft maturation rate close to 2 times that of grafts without PRP. Nevertheless, studies have failed to demonstrate positive effects of growth factors (Aspenberg et al 1989, Lind 1998). High sensitivity of growth factor stimulation to proper delivery systems, correct doses, combinations of growth factors and the associated trauma have been pointed out as important factors (Listgarten 1996, Lind 1998, Bostrom et al 1998).

The effect of mechanical intervention on jaw bone density was investigated by Lundgren et al (1995). In edentulous maxillary jaw regions of rabbits they performed cortical and cancellous bone perforations using a round bur. Compared to the control side, they saw after 8 weeks a substantial increase in trabecular bone density of >100%. They referred the effect to the term "regional acceleratory phenomenon", but they also raised the question if this density increase would be persistent.

IMPLANT STABILITY

Implant stability and bone quality

Implant stability, measured as resistance to unscrewing, was found to depend on the amount of compact bone surrounding the titanium implant (Sennerby et al 1992). Implants placed in cancellous bone of knee joints showed increased bone formation histomorphometrically and increased removal torque over time. Implants placed in tibial cortical bone presented with high removal torque values already after 6 weeks, with no or little increase at 6 months. Cortical bone provided a better implant support at least in the initial postoperative period, and thus efforts should be made to engage as much cortical bone possible during implant placement. This was tested by Ivanoff et al (1996a) in a rabbit model through insertion of implants with mono- and bicortical anchorage. At retrieval, all implants were stable and the degree of osseointegration was assessed with removal torque measurements and histomorphometry. The bicortical implants showed two and three times higher removal torque after 6 and 12 weeks, respectively, compared to monocortical ones. Statistically more bone contact and bone area were seen around the bicortical implants, and based on the study, the authors recommended bicortical anchorage of implants also in the clinical situation. Some clinical studies have shown favourable results with bicortically anchored implants, perforating the floor of the nose and the maxillary sinus (Hessling et al 1990, Jensen et al 1994), while Brånemark et al (1984) demonstrated 10% more implant failures with such an approach. In a more recent paper by Ivanoff et al (1999a), conducting a 15-year retrospective study on patients with mono- and bicortically anchored maxillary implants (Brånemark System®), it was stated rather unexpectedly that bicortical implants failed nearly four times more often than monocortical ones. However, >80% of the failures were implant fractures, which occurred almost three times more often in the bicortical group. The authors speculated on possible causes for the outcome.

Sennerby (1991) referred soft bone to lack of compact bone in the presence or absence of cancellous bone and, based on clinical evidence, he suggested to omit the tapping procedure in such bone to obtain the best primary implant stability possible. In a review report (Sennerby & Roos 1998), primary stability was said to be determined by the density and quantity of the bone, the surgical technique and the design of the implant.

Secondary stability, which may be possible to achieve after the primary healing, was discussed in terms of the degree of primary stability together with the gain in stability as a result of bone formation and remodeling at the implant-bone interface. Ivanoff and coworkers (1996b) investigated the influence of primary stability on osseointegration by inserting titanium implants in tibiae (mainly cortical bone) and femoral condyles (mainly cancellous bone) of rabbits in such a way that some were primarily stable, some showed rotation-mobility and some were totally mobile. They found all the retrieved implants to osseointegrate but demonstrated significantly less amount of bone around the implants placed in cortical bone with initial total mobility. Initial rotation mobility of implants placed in either cortical or cancellous bone was not seen to jeopardize the outcome of the unloaded implants. Orenstein et al (1998) followed 2,641 implants from placement to uncovering, of which 81 implants were regarded mobile at insertion. At abutment connection, 76 of these implants were integrated and presented a mean stability value, as measured with an electronic mobility testing device (PTV), being slightly below the implants with initial stability. According to Sennerby & Meredith (1999), the secondary implant stability, as evaluated with resonance frequency measurements, was lower in maxillae compared to mandibles, and even lower values were seen in grafted maxillae. Contradictory clinical results have been reported for implants placed in soft bone, or rather bone of low density, with assumed poor primary stability and the risk for micromotion during healing. Higher implant failure rates in mainly quality 4 bone (Lekholm & Zarb 1985b) were demonstrated by e.g. Engquist et al (1988), Jaffin & Berman (1991), Jemt (1993) and Sullivan (1997), while Bahat (1993), Venturelli (1996) and Truhlar et al (1997) were quite successful with implants in such situations. With regard to implants placed in patients with osteoporosis-like conditions of the jaws, encouraging results have been presented (Dao et al 1993, Friberg 1994b, Fujimoto et al 1996, Eder & Watzek 1999).

Non-invasive techniques for implant stability measurements

For most clinicians the implant stability is confirmed by **manual clinical testing** of an individual abutment-attached implant, which may be performed by rotating the unit with a gentle clockwise force using an abutment screwdriver. In the absence of mobility and/or pain, according to some of the success criteria proposed by Albrektsson

et al (1986), the implant may be regarded as stable and osseointegrated.

The use of **radiographic examination** in the follow-up period of implant treatment (Gröndal et al 1996) may reveal signs of lost osseointegration in terms of a peri-implant radiolucency. Sundén et al (1995) evaluated the accuracy and precision in the radiographic diagnosis of clinical implant instability. Eight radiologists were asked to determine the presence or absence of peri-implant radiolucencies around 62 unstable and 158 stable implants according to a 5-point rating scale. Interobserver variability was found larger than that of intraobserver. The positive predictive value only amounted to 17%, and the authors concluded that the probability of predicting clinical fixture instability from a radiographic examination can be low in populations with a low prevalence of fixtures showing clinical instability. In a subsequent report by Gröndal & Lekholm (1997), a selected sample from 2,000 patients (about 8,000 implants), comprising 79 patients (413 implants) with 138 radiographically suspected failing implants, were clinically tested for implant mobility. Out of the 138 implants, 114 were found clinically mobile after detaching the prosthetic constructions, resulting in a positive predictive value of 83%. However, another 16 implants (5%) without radiographic signs of failure were found mobile in connection with the clinical test.

Periotest (Siemens GmbH), originally described by Schulte et al (1983) as an electronic device for measuring the damping characteristics of the periodontium, has also been used extensively for stability measurements of oral implants (Olivé & Aparicio 1990, Teerlinck et al 1991, Truhlar et al 1994, Mericske-Stern et al 1995, Tricio et al 1995, Aparicio 1997, Aparicio & Orozco 1998, Orenstein et al 1998). The Periotest comprises a handpiece with a metal rod, which is accelerated to tap a tooth or an abutment four times per second for 4 seconds (16 percussions). The instrument measures the contact time between the rod and the tapped object and the shorter contact time (milliseconds) the more stable periodontium or implant/bone contact. The contact time value is converted with a microcomputer to a numerical value, the Periotest value (PTV). The scale of possible PTVs ranges from -8 to +50, and the lower values (negative scale) represent the most stable implants. Aparicio (1997) referred the PTVs to the bone quality present (Lekholm & Zarb 1985b). In bone qualities 1-3, implants were considered osseointegrated with PTV -7 to 0 and non-integrated with PTV >+5. In quality 4, the corresponding values were -7 to +2 and >+8, respectively. Truhlar and coworkers (1994) found similar mean

PTVs for implants placed in bone qualities 1-3 (-3.8 up to -3.3), while the mean PTV for quality 4 was -1.3. Tricio et al (1995) inserted implants in bovine ribs and correlated the PTVs with insertion torque, bone density and implant length. Significant correlations were seen between PTV and insertion torque and PTV and bone density. The length of the implant did not influence the PTV, but a significant difference between the PTVs for different abutment lengths was found. The relation between PTV and abutment length was also demonstrated by Teerlinck et al (1991). A comparison between PTVs obtained from implants with diameters 3.75 mm and 5.0 mm, revealed lower values (increased stability) for the wide implants (Aparicio & Orozco 1998). Increased stability with increasing implant diameter, as registered with removal torque measurements, was also reported by Ivanoff et al (1997). By using the Periotest instrument on extra-orally positioned implants, Derhami et al (1995) stated that the handling of the instrument could influence the PTV, such as defining the vertical measuring point when tapping the abutment, the angulation of the handpiece and the horizontal distance from the handpiece to the abutment. In a recent report conducted by Meredith et al (1998), it was concluded that the sensitivity of the Periotest to clinical variables, such as striking height and handpiece angulation, limited the application of the instrument as a clinical diagnostic aid to measure implant stability.

The utilization of **resonance frequency (RF)** measurements for quantitative determination of the stability of the implant-tissue interface was described by Meredith et al (1996a). Implants of different lengths were inserted in an aluminum block with different heights (0-5 mm) of the implants left exposed. A transducer, which was attached via a screw on top of the implant, comprised a small beam with two piezo-ceramic elements. With a frequency response analyser (Model 1510; Schlumberger Ltd., Crawley, England), one of the elements was excited with a sinusoidal signal, which varied in frequency from 5kHz to 15 kHz in steps of 25 Hz, and with a peak amplitude of 1 volt. The response was measured by the other element and amplified before being fed back into the frequency response analyser. The first flexural response of the resulting system was observed as a marked increase in amplitude. A strong correlation was shown between the RF value and the exposed height of the implant above the block, while the overall implant length was of no significance. One implant (diameter 3.75 mm) was placed in a 5-mm diameter hole in a steel block filled with self polymerising acrylic resin, thereby simulating the

change in stiffness during bone formation and healing. RF was measured at 30-seconds interval during the curing process. The RF value increased over time, and it was demonstrated that the transducer was sensitive to changes in stiffness. The repeatability was also tested and found to be <1%. The influence on RF by tightness with which the transducer was attached to the implant was negligible when tightening the transducer screw with a torque >10 Ncm. RF measurements have been used on implants in rabbit models (Meredith et al 1996b, Meredith et al 1997a) and in patients (Meredith et al 1997b), and recorded RF values of implants successfully integrated showed an increase during the healing period. Two implants that were found mobile at abutment connection (patient study), demonstrated decreased RF values as compared to the ones registered at implant insertion. The authors concluded that the RF of an implant/transducer system was related to the height of the implant not surrounded by bone and the stability of the implant/tissue interface as determined by the absence of clinical mobility. Heo et al (1998) found higher RF values for extra-oral implants placed in the temporal bone compared to the bone in the nose and peri-orbital regions, which they assumed depended on the difference in bone density. There was also a positive correlation between RF values and time. In a series of investigations, Rasmusson et al (1997, 1998b, 1999a+b) reported on stability measurements with RF on implants subjected to barrier membrane induced bone augmentation and implants in bone grafts. The membrane induced bone formation did not have any influence on the implant stability as compared to controls, when measured with RF and removal torque tests. Increased stability with time was demonstrated for implants placed simultaneously with bone grafts and significantly more so with a delayed implant placement approach.

Implant stability and duration of healing

Brånemark et al (1977) stated that the remodeling period after implant insertion will continue for at least 18 months. With regard to removal torque measurements, longitudinal studies on the bone tissue response to titanium implants have shown increased values over time (Johansson & Albrektsson 1987, Sennerby et al 1992, Ivanoff et al 1996a). It was demonstrated that not only the amount of bone but also the type of bone (cancellous versus compact) surrounding the implant influenced the removal torque. Furthermore, it was shown that cancellous bone could "catch up" with cortical bone over time (Sennerby

et al 1992). Increased implant stability during follow-up periods, as one indication of successful osseointegration and measured with Periotest or resonance frequency, has been reported in numerous studies (Mericske-Stern et al 1995, Meredith et al 1997a+b, Aparicio & Orozco 1998, Heo et al 1998, Rasmusson et al 1998b). The cause for this time-dependent increase in implant stability may be found in bone histology and histomorphometry studies conducted by several investigators (Johansson & Albrektsson 1987, Sennerby et al 1992, Ivanoff et al 1996b, Mori et al 1997). In the rabbit study by Johansson & Albrektsson (1987), the bone-to-implant contact was shown to increase from a few percent at 3 weeks to 85% at one year. They concluded that the osseointegration process would continue at least for a year in rabbits and that longer time would be anticipated in man due to the more slow bone turnover. It was also suggested that an extended healing period was needed for implants placed in bone of little volume and/or low density. The latter is in accordance with the results presented by Mori et al (1997), who established an experimental rabbit model with bone of low mineral density (osteoporosis-like) and investigated the amount of bone-to-implant contact at 2, 4, 8 and 12 weeks after implant placement. As compared to controls at 8 weeks, similar histomorphometrical results were obtained with the implants in bone of low density at 12 weeks. Consequently, it was proposed an extended healing period in patients with osteoporosis-like bone.

One- versus two-stage techniques/delayed versus immediate loading

The rationale behind the two-stage (submerged) surgical technique, i.e. implants and abutments are placed at two different sessions as described by Brånemark et al (1985), was to avoid preloading/micromotion of the implant and to allow for bone formation and integration to occur. Thus, it was anticipated that an increased implant stability would be achieved during the healing period. Successful use of a one-stage (non-submerged) procedure in maxillae and mandibles mainly, and with healing periods of 3-6 months, has, however, been reported for ITI implants (Buser et al 1991, Mericske-Stern et al 1995, Åstrand et al 1996a, Buser et al 1997), as well as for the Brånemark System[®] (Ericsson et al 1994, Henry & Rosenberg 1994, Bernard et al 1995, Becker et al 1997, Ericsson et al 1997, Hermans et al 1997, Collaert & De Bruyn 1998). With regard to the study of Ericsson et al (1994), a split mouth technique was executed using both

one- and two-stage implants within the same jaw. At the 5-year follow-up (Ericsson et al 1997) of the same patient material, similar implant stability (Periotest) and radiographic marginal bone levels were recorded for both groups of implants. The patients of the studies referred to were allowed to wear their relined dentures immediately (Henry & Rosenberg 1994, Becker et al 1997), after one week (Bernard et al 1995), after two weeks (Ericsson et al 1994) or not at all during the healing period of 3-4 months (Collaert & De Bruyn 1998). In the Henry & Rosenberg (1994) study, prosthodontic procedures were commenced already at 7-10 days post surgery and fixed permanent bridgeworks were attached 7-9 weeks after implant placement. No implants were lost during the 2-year study period. The assumed unfavourable loading of the denture during healing was obviously possible to control, since all studies showed implant survival rates at the 1-year check-up of 94-100%. The result of 94% obtained by Ericsson et al (1994) at 18 months was also consistent with the outcome at 5 years (Ericsson et al 1997). In a recent investigation, Randow et al (1999) reported on 16 patients (88 implants) with edentulous mandibles, in whom permanent fixed suprastructures were connected within 20 days following implant placement. None of the implants were lost during the follow-up period of 18 months. Hence, one-stage surgery and early loading of implants in mandibles with dense bone and two well defined cortical layers indicate that implants may survive, despite that bony ingrowth at the bone-to implant interface has as yet not occurred.

Schnitman et al (1990) placed both submerged and non-submerged implants in mandibles with the effort to provide patients with interim fixed constructions at the day of stage-one surgery. After 3-4 months, the submerged implants had abutments connected and definitive restorations were fabricated. Three implants of 20 immediately loaded were lost during a 21-month period (15%), and the result was consistent with the 10-year report presented by the same authors (Schnitman et al 1997). A similar approach was used by Tarnow et al (1997), who inserted ≥ 10 implants in each jaw, of which ≥ 5 implants were immediately loaded, in both edentulous mandibles (6 patients) and maxillae (4 patients). All implants were 10 mm or longer, and out of 107 implants of different systems 67/69 non-submerged and 37/38 submerged implants osseointegrated and were regarded successful during the study period of 1-5 years. The authors concluded that a delayed loading protocol was still the treatment of choice, although, for a particular population, immediate loading of multiple implants splinted across the arch could be a valuable

adjunct to therapy. The ultimate goal regarding immediate loading was reached by Brånemark and coworkers (1999), who reported on the one-day treatment protocol (Brånemark Novum®) with permanent fixed implant supported reconstructions in edentulous mandibles. Fifty patients with 150 implants were followed from 6 months to 3 years with no adverse effects on the marginal bone level and with an overall implant survival rate of 98% after 2 years.

General remarks on literature review

Osseointegration, as implied that a rigid fixation of the implant surface is achieved and maintained in bone during functional loading (Zarb & Albrektsson 1991), is the aim of implant surgery. Determinants for achieving osseointegration have been suggested, such as the present bone quality and volume, the surgical technique, the obtained primary implant stability and an adapted healing period (Ivanoff 1999c). The obtained secondary implant stability and the loading conditions are on the other hand suggested as the determinants for maintaining the osseointegration (Sennerby & Meredith 1998).

When summarizing the literature it may be stated regarding the anatomically related features that questions have been raised on how these conditions are defined and used in conjunction with the oral implant treatment. While bone volume may be determined by objective clinical and radiographic examinations, bone quality scoring is mainly based on quantitative radiographic measures and subjective opinions of the performing surgeon. When considering the surgical technique, in general only one surgical protocol is offered when executing the implant placement in bone of various textures. Therefore, the obtained primary implant stability is mainly discussed in terms of the pre-set motor torque and the subjective hand-felt perception during final tightening of the implant, whereas the obtained secondary implant stability is mainly defined as the absence of implant mobility during the abutment operation and the subsequent prosthetic procedure and follow-up. Furthermore, when considering the duration of the healing period, mainly the empirical periods of 3 to 6 months have been suggested for mandibles and maxillae, respectively. Shorter healing periods have been introduced in connection with the concept of direct or early loading, but prolonged healing have rarely been mentioned for use in the clinical practice.

Consequently, despite the numerous reports available on the use of the Brånemark

implant technique, still more knowledge regarding various issues is requested in order to further improve the clinical outcome of implant treatment. The influence of bone quality on early and late implant failures needs e.g. to be verified, and thus a technique to identify and objectively measure the bone quality or bone hardness during implant placement is desired. The influence of bone quality on primary and secondary implant stability needs to be investigated as well, and therefore a technique to identify and repeatedly measure the obtained implant stability is requested. The influence of variations in the surgical performance and of different healing periods on the outcome of implants also needs to be explored in relation to various bone quality situations. To be able to answer these questions, both clinical and experimental studies are needed.

AIMS

The research goals of the investigations on bone quality and implant stability measurements executed as part of the present thesis were to:

- Study the frequency of early and late failures of Brånemark System® implants; and to relate this outcome to differences in the surgical protocol, as well as to various patient and implant characteristics (study I, IV).
- Test *in vitro* the reliability of true cutting resistance measurements in simulated clinical situations, using two investigators, different handpressure and deviating tapping directions; and to correlate values of bone density with values of true cutting resistance (study II).
- Investigate the applicability of true cutting resistance measurements, comparing maxillae and mandibles as well as different regions of post mortem human jaws; and to correlate values of bone area and density, respectively, as measured in microradiographs, with values of true cutting resistance of the same jaw site (study III).
- Compare *in vivo* obtained cutting torque values of maxillae and mandibles as well as of different jaw regions; to perform correlation analyses between cutting torque values and assessed scores of bone quality; and to identify implants at risk based on their cutting torque values (study IV).
- Obtain *in vivo* values of cutting torque and resonance frequency at implant insertion in edentulous maxillae for subsequent correlation analyses; to study, over a period of 20 months, changes in implant stability as measured by resonance frequency; and to relate changes in resonance frequency to registered marginal bone levels at abutment operation and at 1-year follow-up (study V).
- Study changes in implant stability during healing via repeated resonance frequency measurements, using a one-stage surgery approach in edentulous mandibles; and to relate changes in resonance frequency to registered marginal bone levels at the end of the study period (study VI).

MATERIALS & METHODS

Experimental studies (II, III)

Test samples

Frozen ribs of 7-month-old pigs were used after being thawed and sectioned into 30 mm long pieces for the study II analyses. In all, 17 seemingly homogeneous samples, with well defined cortices surrounding a trabecular bone cord, were examined (Fig. 1).

In study III, 10 jaw samples (6 maxillae and 4 mandibles) were obtained from 7 corpses (3 women and 4 men; mean age: 73 yrs, range 61-90 yrs), subjected to educational dissection at the Department of Anatomy, Göteborg University, Sweden. The material had been preserved in 4% formalin for 6-8 weeks prior to retrieval. The specimens were harvested, freed from mucoperiosteum, again preserved in formalin and stored in a refrigerator until used 2 weeks later.

Study protocols

Implant sites were prepared according to the guidelines described by Adell et al (1981), always aiming at engaging the basal compact bone layer (studies II, III). During low speed threading, values of total torque were registered by a computer (Copam, Pc-401, Turbo), connected to a motor unit (Nobel Biocare AB, Göteborg, Sweden). Torque

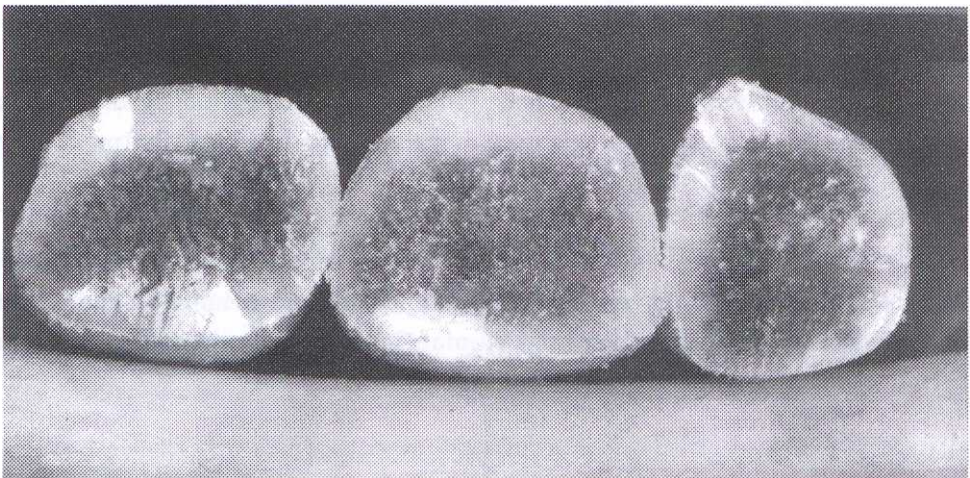

Figure 1. Sectioned pig ribs used as test samples in study II.

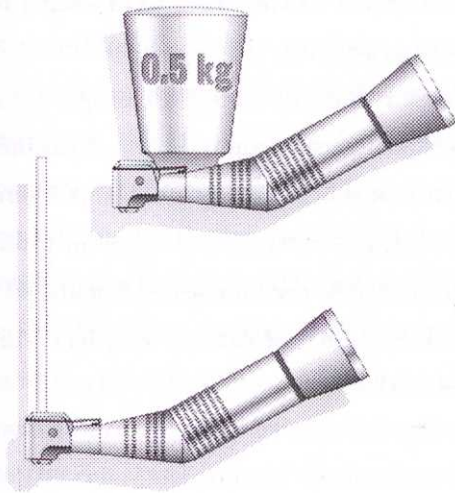

Figure 2. Specially prepared motor handpieces used in study II

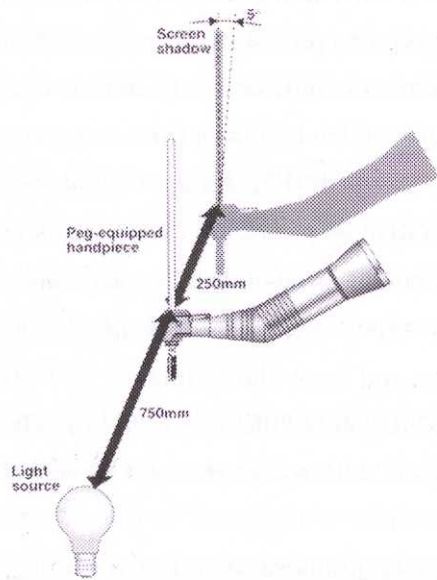

Figure 3. The principle set-up in study II, giving a silhouette on a screen when using the guide-peg-equipped handpiece in different threading directions

graphs were printed for all implant sites. Measured torque consisted of true cutting resistance, friction and idling speed energy. By using a special computer software (Johansson & Strid 1994), friction and idling speed were subtracted, and the true cutting resistance, expressed in mJ/mm^3 , was calculated for each site (studies II, III).

In study II, the reliability of the Johansson & Strid (1994) technique was evaluated, using specially prepared motor handpieces (Fig. 2) to test variations in the manual handling. In each rib sample, 3 sites were prepared (in total 51 sites), whereafter threading was performed in the following three different manners:

with the screw tap placed in a vertical position (standard)

with the screw tap deviating 5 degrees (Fig. 3)

with the screw tap placed in a vertical direction and applying an additional weight of 0.5 kg

The threading was executed by two investigators and followed a rotational scheme among the sites to compensate for possible differences in bone structure. Three new screw taps were used, one for each threading protocol. Mean values of true cutting resistance of each tapping procedure were calculated. Titanium implants (Brånemark System®) of 13-20 mm in length and 3.75 mm in diameter were inserted in the one site of each rib sample, which had been threaded using the standard procedure.

In study III, the applicability of the Johansson & Strid (1994) technique was evaluated, by preparing 31 implant sites: 13 incisor (9/4; maxillae/mandibles), 5 canine (2/3) and 13 premolar (6/7) ones, respectively, in 10 post mortem jaw samples. A fresh screw tap was used for each specimen. Mean values of true cutting resistance for total upper and lower jaw samples, as well as for different jaw regions, were calculated. Following threading, titanium implants (Brånemark System®) of various lengths (7-18 mm) and with a diameter of 3.75 mm were inserted in the sites.

Specimen preparation and microradiography

All specimens including implants (studies II, III), were fixed by immersion in 4% buffered formalin for 3 days, dehydrated in graded series of alcohol and embedded in plastic resin. About 100- μ m-thick undecalcified cross-sections of implants and surrounding bone tissue were prepared using sawing and grinding techniques (Donath & Breuner 1982). In this way, 17 (study II) and 28 (study III) ground sections, respectively, became available for further analyses. Due to handling problems, three of the test sites in study III were not possible to evaluate.

A microradiograph of each ground section was obtained using a Kodak high-resolution plate (type 1 A) and Machlett X-ray tube (type OEG-50) at 27 kV and 14 mA for 20 minutes. The plate was developed using Kodak D-19 developer for 5 minutes during agitation at 20°C.

Densitometric/morphometric analyses

All microradiographs (studies II and III) were examined in an Olympus microscope equipped with a high-resolution video camera and connected to an Apple Macintosh II computer interactive image analysis system. The light transmittance of each image was captured by the video camera and the video signal was converted into a 256-level gray

scale in a matrix of 768 x 512 pixels. The video signal was monitored live on the computer screen, and the light transmittance in the regions of interest was adjusted to a high contrast. Length calibration was performed against a steel micrometer instrument with an accuracy of ± 3 pixels ($0.3 \mu\text{m}$) and repeated horizontally and vertically, once for each section. LUT (Look Up Table) was applied, setting the film "zero-transmittance" (background) to 255 (black).

By using a dedicated software (Image 1.37, National Institute of Health Research Services, NIMH, USA), a mean density profile was obtained from each specimen, expressing the bone distribution along two 0.35 mm wide corridors. These were placed on each side of the implant, tangentially to the tip of the threads and extending from the neck to the final apical thread of the fixture.

The mean density profiles were compared intraindividually with the mean torque profiles, the latter obtained from the cutting resistance measurements. In study II, three peaks were identified by measuring the distance from the start of the graph, corresponding to the reference point of the implant (Friberg et al 1992), to the maximum density and torque peaks in the upper and lower halves of the implant site, as well as to the minimum density and torque peaks along the whole implant site. In study III, the corresponding distances were measured to the maximum density and torque peaks along the whole implant site.

Areas of total, cortical and trabecular bone, respectively, were quantified in two 0.7 mm corridors (Fig. 4) placed around each implant as described above. By using the aforementioned analysing software, a grey scale interval corresponding to that of bone was determined manually via the computer by continuous comparison with the specimen in the microscope. The identified mineralized bone was painted red in the computer picture and areas of total, cortical and trabecular bone were then computer calculated and expressed as the percentage of bone area in the corridor (study II, III). Mean values were calculated for all (17) rib samples (study II) and for all (28) upper and lower post mortem jaw samples, including different jaw regions (study III).

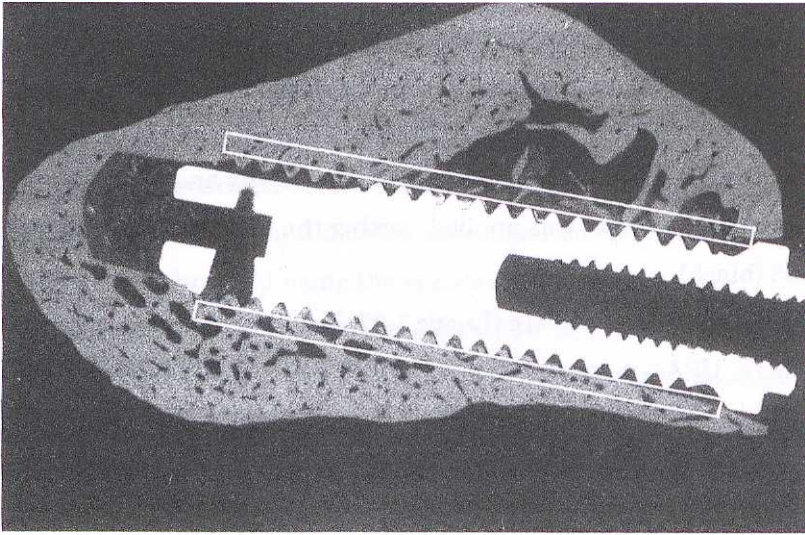

Figure 4. A microradiograph with two 0.7 mm wide corridors for bone area measurements (studies II, III).

Statistical analyses

When comparing the three different threading procedures, statistical analyses were executed with the use of Student t-test for paired samples and Wilcoxon signed-rank test. For interindividual comparison between the two investigators, the Student t-test for independent samples and Wilcoxon rank-sum test were utilized (study II).

Comparisons of mean true cutting resistance values, as well as of mean total bone area values of maxillae and mandibles, respectively, were performed with the Wilcoxon rank sum test (study III).

When correlating the obtained profiles of density and torque, the Spearman's rank correlation test was used (studies II, III). The same test was also utilized when correlating true cutting resistance and total bone area values (study III).

A significant difference/correlation was considered for $p \leq 0.05$.

For test of sample homogeneity (study II), mean values with standard deviations and confidence intervals at the 0.95 probability level were calculated for the distances from start of the graphs to the three peaks of density and torque profiles, as well as for total, cortical and trabecular bone, respectively. The Student t distribution with 16 degrees of freedom was thereby used.

The precision of bone area measurements was calculated by repeating measurements once in 6 specimens with 3 weeks interval (study II).

Clinical studies (I, IV-VI)

Patients

A total of 889 consecutive patients (943 jaws), representing both complete and partial edentulism and treated with implants during a 3-year period, were included in study I. All patients, were followed from stage-one surgery to the connection of prosthetic constructions. The degree of edentulism, as well as jaw and sex distributions, revealed a preponderance of complete edentulism (780/943), mandibles (564/943) and females (510/889), and the patient mean age was 57.5 years (range 13-88 years) at implant insertion.

A total of 105 consecutive patients (106 jaws), representing both complete and partial edentulism and treated with implants during a 13-month period, were included in study IV. Due to that 3 patients were kept in geriatric care, 4 patients deceased, 1 patients did not show up at recall visits and 2 patients lost all implants, 95 patients remained for the final evaluation at 3 years. The degree of edentulism, as well as jaw and sex distributions, revealed a preponderance of complete edentulism (72/106), maxillae (62/106) and females (61/105), and the patient mean age was 64 years (range 18-86 years) at implant insertion.

A subsample of 9 consecutive patients of the study IV patient material, representing edentulous maxillae, were included in study V. The sex distribution revealed a preponderance of females (6/9), and the patient mean age was 67 years (range 55-80 years) at implant insertion.

A total of 15 patients, representing edentulous mandibles and treated with implants during a 1-year period, were included in study VI. The sex distribution revealed a preponderance of females (9/15), and the patient mean age was 68 years (range 49-77 years) at implant insertion.

Presurgical evaluation

Preoperative radiographic (Gröndahl et al 1996) as well as clinical examinations, including evaluation of medical conditions, were performed for all patients (studies I, IV, V, VI) according to the recommendations described by Lekholm & Zarb (1985b) and Lekholm (1997). Jaw bone shape was scored according to a 5-graded classification from A to E (studies I and VI), and jaw bone quality was scored according to a 4-graded classification from 1 to 4 (studies I, IV, V and VI) (Lekholm & Zarb 1985b). A deviation

from the protocol of the Lekholm & Zarb index (1985b) was executed in study IV, since each site (420 sites), and not the overall jaw, was assigned a quality figure, based on preoperative radiographs and the hand-felt perception of the drilling resistance.

Implant characteristics and treatment protocol

All implants used in the present studies were manufactured by Nobel Biocare AB, Göteborg, Sweden.

In study I, a total of 4,641 implants (mainly standard diameter 3.75 mm) with lengths ranging from 7 to 20 mm, were submergedly inserted using a two-stage surgical technique (Adell et al 1981). In maxillae with complete and partial edentulism, 1,529 and 200 implants were inserted, respectively, and the corresponding figures for mandibles were 2,642 and 270 implants. Implants were identified according to their positions as central (closest to the midline), terminal (the most posteriorly inserted) and intermediate (all implants between central and terminal). All patients received antibiotic prophylaxis with phenoxy methyl penicillin (Kåvepenin™, Astra AB, Södertälje, Sweden), starting with 2 gr one hour before surgery and continuing for 10 days post surgery with 2 gr twice a day. In case of penicillin allergy, 500 mg of erythromycin (Ery-Max™, Astra AB, Södertälje, Sweden) was given at two daily occasions during 10 days. When fixtures failed to integrate, patient files were retrospectively examined with regard to mentioned errors and complications during surgery, initial implant stability, bone defects at implants sites, etc.

In study IV, a total of 523 implants were inserted, of which 420 were of the self-tapping Mk II design (diameter 3.75 mm) and with lengths ranging from 10 to 18 mm. The remaining 103 implants were either of the standard diameter with lengths of 7 or 8.5 mm (48/103), or of diameter 4.0 mm (43/103) with lengths ranging from 7 to 18 mm, as well as of diameter 5.0 mm (12/103) with lengths ranging from 6 to 12 mm. A deviation from the original surgical protocol was executed for the Mk II implants by omitting the threading procedure in both maxillae and mandibles. With regard to the other implants, and irrespective of implant diameter, threading was rarely performed in these sites, since they were mainly located in maxillary bone of low density and little volume. Furthermore, in these low density sites an adapted insertion technique was carried out, using implant diameters of 4.0 or 5.0 mm after preparing the sites to a final diameter of

3.0 mm. All implants were submergedly placed using a two-stage surgical technique (Adell et al 1981). With regard to penicillin prophylaxis, the first 70 treated patients received the same type and dose as was administered in study I. During the study period, the use of prophylactic antibiotics at the clinic was reduced and the subsequent 35 patients were only given a single, one-hour preoperative dose of 3 gr of amoxicillin (Amoxicillin NM Pharma™, NM Pharma AB, Stockholm, Sweden), or in case of allergy, a single dose of 600 mg clindamycin (Dalacin™, Upjohn AB, Partille, Sweden).

In study V, the patient subsample of study IV comprised 61 implants, of which 49 were Mk II implants. The remaining 12 implants belonged to either of the other designs previously described in study IV. Implant sites were prepared according to the technique described in study IV, and implants were placed submergedly (Adell et al 1981). Antibiotic prophylaxis was given according to the same principles as described in study I and for the first 70 patients treated in study IV.

In study VI, a total of 75 implants (diameter 3.75 mm) of various lengths (10 -18 mm) were inserted, of which 25 were of the standard and 25 of the Mk II design, while 25 were self-tapping implants with conical heads (Lekholm 1990), originally designed for low bone density sites. Due to the dense character of the mandibular bone in this study, both the standard and the self-tapping (conical heads) implants were inserted after threading the sites, while for the Mk II implants this procedure was omitted. A change of the surgical protocol was also executed by using a one-stage technique (Ericsson et al 1994). With regard to the self-tapping implants, countersinking was abandoned, since their conical heads were placed in a non-submerged position (Fig. 5). Thus, the latter implants served as both anchorage units and transmucosal abutments. Cylindrical standard abutments (4-10 mm long) were connected immediately after implant placement on the standard and Mk II implants. For all patients in study VI, similar antibiotic regime was used as for the last 35 patients treated in study IV.

Cutting torque measurements

In studies IV and V, an electronic instrument (Nobel Biocare AB, Göteborg, Sweden), based on the technique described by Johansson & Strid (1994), was used for total torque measurements during insertion of Mk II implants. The instrument was connected to a Torque Controller™ (Nobel Biocare AB, Göteborg, Sweden) and the time-torque data

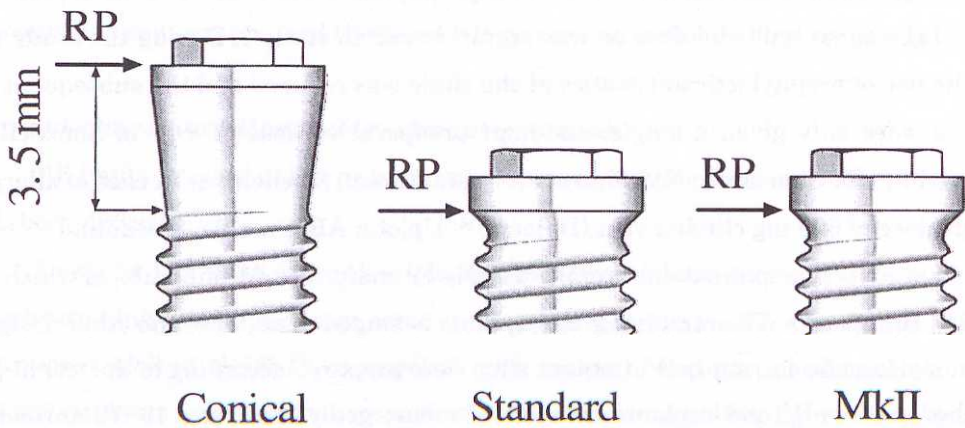

Figure 5. Three implant designs with their radiographic reference points (RP) marked (study VI).

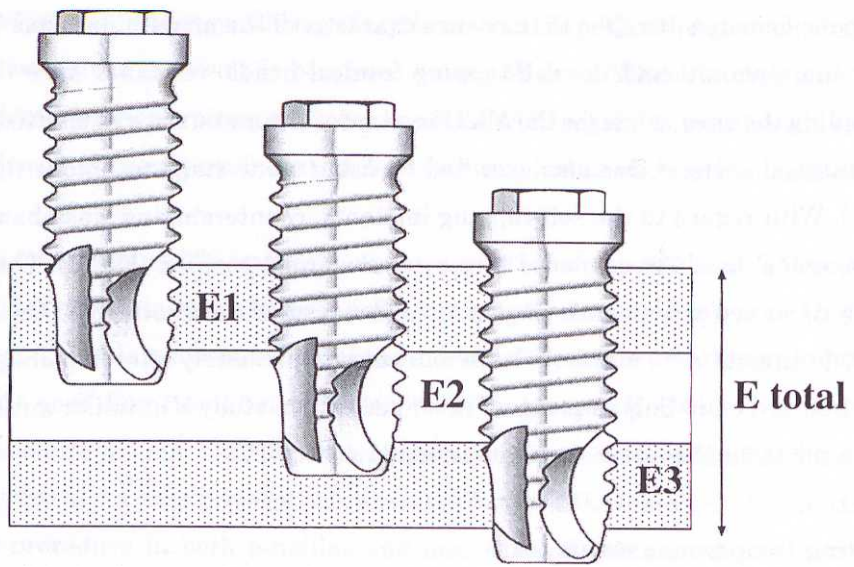

Figure 6. Illustration of cutting torque measurements during Mk II implant insertion, as conducted for upper (E1), middle (E2) and lower (E3) third of the implant site, as well as for the whole implant site (E-total)(studies IV and V).

was recorded by a memory card during low-speed implant placement. Only the idling speed energy, which was recorded at all implant sessions, was subtracted from the total torque value. The remaining torque, i.e. the cutting torque, which comprises the true cutting resistance of bone as well as the friction torque including bone material packing around the implant, was presented as a mean value in Ncm for the upper/crestal (E1), the middle (E2) and the lower/apical (E3) third portion, respectively, as well as an overall value for the whole implant site (E-total) (Fig. 6). Due to technical problems, 8 of the 420 sites were not possible to measure regarding cutting torque in study IV, while all 49 Mk II implants were measured in study V. The remaining implants, 103 (study IV) and 12 implants (study V), respectively, were not subjected to cutting torque measurements due to limitations of the computer software.

Resonance frequency (RF) measurements

RF measurements (Meredith et al 1996a) were performed at three occasions in study V, i.e. at implant placement, at abutment connection (8 months post surgery) and at the 1-year follow-up (20 months post surgery). Following implant insertion, a 4 mm long standard abutment (Brånemark System[®]) was connected to each individual implant, one at a time. On top of the abutment an L-shaped transducer with two piezo-ceramic elements was attached by means of a screw, and oriented perpendicular to the alveolar ridge with its upright beam positioned palatally/lingually (Fig. 7). With the use of a frequency response analyser (Model 1512; Schlumberger Ltd., Crawley, England), one of the elements was excited by a sinusoidal signal at frequencies over the range of 5-15 kiloHertz (kHz) in steps of 25 Hz, and the response was measured by the second element, amplified and fed back to the frequency response analyser. The RF was calculated from the received signal and data stored and analysed in a personal computer. Due to technical problems with the equipment, 2 of the 49 Mk II implants were not measured with RF. After registrations, the submerged implants were allowed to heal for eight months. At second stage surgery, RF measurements (n=47) were again executed by utilizing the permanent abutments of non-standard design, only 36 implants were exposed to RF measurements at the one-year follow-up visit. Abutments of other design than standard were not possible to use together with the transducer and it was not considered feasible to exchange them for the final registration procedure.

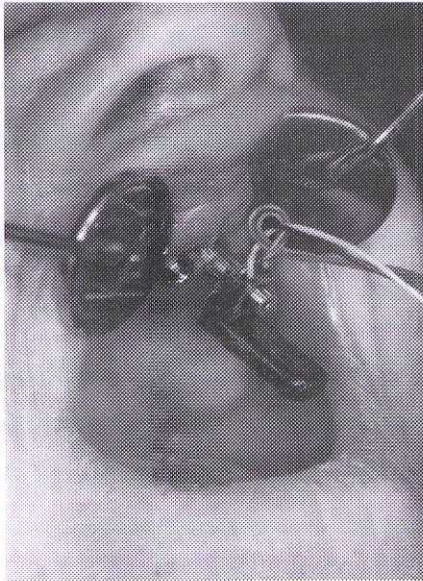

Figure 7. *A transducer attached to the implant/abutment for resonance frequency measurements (studies V, VI).*

In study VI, RF measurements were carried out using the same type of equipment as described in study V. Two different transducers were used, however, one for implant level measurements (implants with conical heads) and one for abutment level measurements (standard and Mk II implants). Various abutment lengths were used and, thus, the height of the implant/abutment being exposed above the bone level differed. Therefore, recorded values of RF had to be computer calculated for equivalence. Due to the non-submerged approach, implants were accessible for repeated RF measurements throughout the healing period, and registrations were made at 1, 2, 6 and 15 weeks post surgery. For one patient, who presented lowered RF values at 6 and 15 weeks, the study period was extended to 30 weeks.

Duration of healing and prosthetic procedures

Dentures were temporarily relined and returned to the patients two weeks postoperatively (studies I, IV, V, VI). Healing periods of 3-4 months for mandibular implants were used in studies I, IV and VI, while the majority of maxillary implants in studies I and IV were allowed to heal for 6 months (Adell et al 1981). For all implants in study V and for those placed in maxillae of low bone density in study IV, an extended

healing (8 months) was utilized.

The implant-supported fixed reconstructions in studies IV (n=111), V (n=9) and VI (n=15) were manufactured either in high precious gold alloy (Zarb & Jansson 1985) or in titanium (Jemt et al 1999). One patient in study IV received a removable overdenture in the upper jaw attached to implants (Engquist et al 1988). Due to the non-submerged position of the conical implants in study VI, the prosthetic devices were connected directly onto the implants without any interpositional abutments (Fig. 8).

Radiographic examinations

Postoperative radiographs (Gröndahl et al 1996) were obtained at abutment operation (studies I, IV, V and VI) to check the fit of the components at the implant/abutment level. For implants of standard and MK II designs in study VI, abutment operation coincided with implant placement surgery. One patient was examined with intraoral radiographs at 6 weeks of follow-up due to a delayed soft tissue healing (study VI). Radiographs were also taken after attaching the prosthetic constructions (studies IV, V,

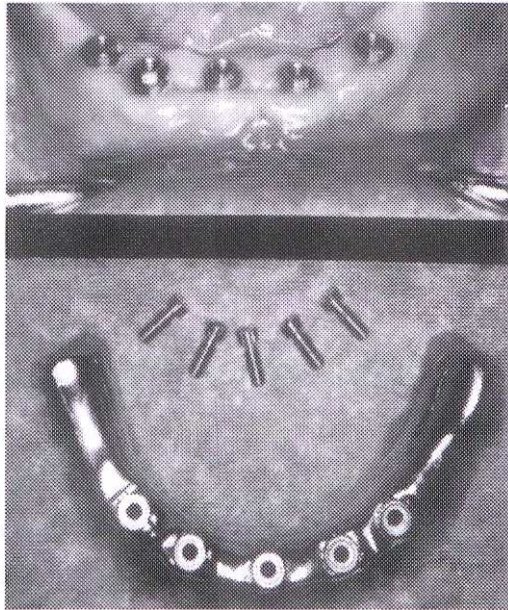

Figure 8. A fixed prosthesis to be connected directly onto implants, without intervening abutments (study VI).

VI) to check the fit of the components at the abutment/prosthesis level. The latter images were used to identify the marginal bone level mesially and distally to all implants, measuring the distance from the reference point of the Mk II implant (study V) or from various reference points (study VI) (Fig. 5). When calculating the marginal bone levels for the conical implants (study VI), a value of 3.5 mm, corresponding to the height of the tapered collar, was subtracted from the registered bone level values. Furthermore, at the one-year check-up (study V) radiographs were obtained and the marginal bone loss was determined during the first year of function.

Statistical analyses

Study I was designed as a descriptive paper and thus, no statistical analyses were performed.

In study IV, mean cutting torque values (E1, E2, E3 and E-total, respectively) of Mk II implants sites were used for the following analyses:

one implant per jaw was randomized and values of maxillae and mandibles were ranked and compared, using the Wilcoxon rank-sum test.

one implant per jaw region was randomized (incisor, canine and premolar) and values of different regions (maxillae and mandibles separately) were compared, using the Friedman's test.

values with standard deviations of failed Mk II implants were compared with the corresponding values of successful Mk II implants. Too few losses were at hand for statistical analyses.

one implant per jaw was randomized and values were plotted against the assessed bone quality score of the corresponding site, using the Spearman's rank correlation test.

In study V, patient (n=9) and Mk II implant site (n=47) mean cutting torque values (E1, E2, E3 and E-total, respectively) were plotted against the corresponding resonance frequency (RF) values.

The patient mean E1-value (n=9) was plotted against the patient mean difference in resonance frequency between implant placement and abutment operation, i.e. against the figure for change in implant/tissue stiffness occurring during healing. All correlation analyses in study V were performed using the Spearman's rank correlation test.

The 47 E1-values were further divided into three subgroups (16+16+15=47) based

on differences in bone density. The mean value for each group was plotted against the corresponding mean RF value at implant placement (n=47), at abutment operation (n=47) and at the one-year follow-up (9+13+14=36). The Student t-test for independent samples was utilized for test of the null hypothesis.

When comparing the mean RF values (all groups included) at implant placement (n=47), at abutment operation (n=47) and at the first annual check-up (n=36), the Student t-test for paired samples was used.

In study VI, the Student t-test for paired samples was used to test the null hypothesis with regard to the change in patient mean RF values (n=15) from implant placement to the connection of the fixed prosthesis.

When comparing the mean marginal bone level values of the three implant designs at 15 weeks, the Student t-test for independent samples was used.

In studies IV, V and VI, a significant difference/correlation was considered for $p \leq 0.05$.

RESULTS

Experimental studies (II, III)

Reliability test (II)

Mean values of true cutting resistance in pig ribs for the three threading modalities (Table 1), as well as for the two investigators, showed no significant differences ($p > 0.05$).

Morphometric analyses of the 0.7 mm corridors along the implant surface for evaluation of sample homogeneity revealed the following values:

total bone area; $50.6\% \pm 6.6\%$; (47.2 - 54.0% with 95% confidence interval)

compact bone area; $29.8\% \pm 7.9\%$; (25.7 - 33.8%)

trabecular bone area; $20.8\% \pm 6.6\%$; (17.4 - 24.2%)

Regarding the repeated bone area measurements in 6 specimens, the precision was calculated to be $\pm 1.12\%$.

When measuring distances from start of the registration to the maximum density and true cutting resistance peaks in upper and lower parts of the test samples, as well as the corresponding distances to the minimum density and cutting resistance peaks along the whole site, the following mean values with 95% confidence intervals were obtained: upper maximum density: 1.07 mm (0.90 - 1.24 mm); upper maximum cutting resistance: 1.11 mm (0.96 - 1.26 mm); lower maximum density: 13.06 mm (12.16 - 13.95 mm); lower maximum cutting resistance: 13.43 mm (12.64 - 14.22 mm); minimum density: 7.22 mm

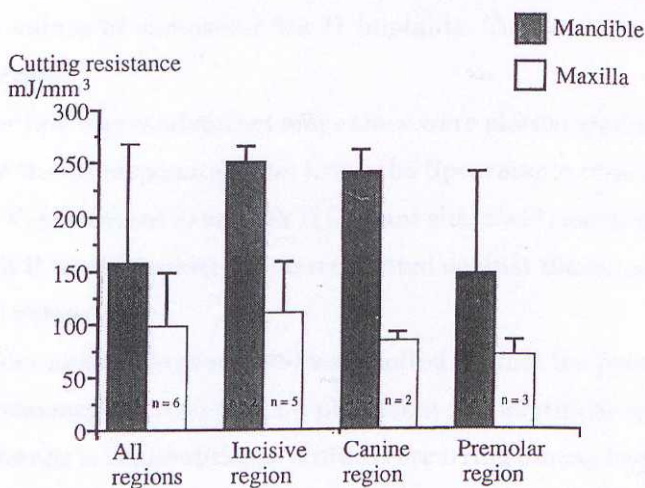

Figure 9. Diagram showing the mean true cutting resistance values in mandibles and maxillae, as well as in different jaw regions (study III).

Table 1. Mean values of bone cutting resistances in pig ribs, expressed in mJ/mm³, and measured for three different tapping procedures

Bone tapping procedures	$\bar{x} \pm SD$
Vertical direction no load (standard)	88.8 ± 29.7*
Deviation 5 degrees no load	89.3 ± 26.9*
Vertical direction 0.5 kg load	79.4 ± 24.0*

* No statistically significant differences existed between any of the values

(5.76 - 8.70 mm); minimum cutting resistance: 7.64 mm (6.56 - 8.72 mm)

A significant correlation ($p < 0.05$) was found between distances to the maximum (lower part) density and cutting resistance peaks, as well as to the corresponding minimum peaks, respectively. Regarding the maximum peaks in the upper part, no significant correlation ($p = 0.16$) was seen, due to two divergent density values.

Applicability test (III)

A significant higher ($p < 0.001$) mean cutting resistance value was seen for mandibles (159.2 ± 103.7 mJ/mm³) compared to maxillae (99.5 ± 49.4 mJ/mm³), although few samples were available for statistical analysis (Fig. 9). There was a tendency towards declining values in posterior direction of both jaws, especially when comparing incisor and premolar regions (Fig. 9). The material was too small for statistical comparisons between different regions.

Specimens from mandibles showed in general a dense and thick outer compact layer with wide trabeculae in the center, while maxillae were characterized by a thin and indistinct compact layer and a central part with thin trabeculae.

A significant higher ($p < 0.001$) mean total bone area value was seen for mandibles ($55.0 \pm 8.2\%$) compared to maxillae ($31.4 \pm 4.3\%$), although few samples were available for statistical analysis (Fig. 10). There was a tendency towards declining values in posterior direction of both jaws, especially when comparing incisor and premolar regions (Fig. 10). The material was, however, too small for statistical comparisons between different regions.

With regard to the amount of compact and trabecular bone, a significant difference ($p < 0.05$) was seen between the two jaws, with a mean ratio (compact/trabecular) of 2.92 in mandibles and 1.97 in maxillae, respectively.

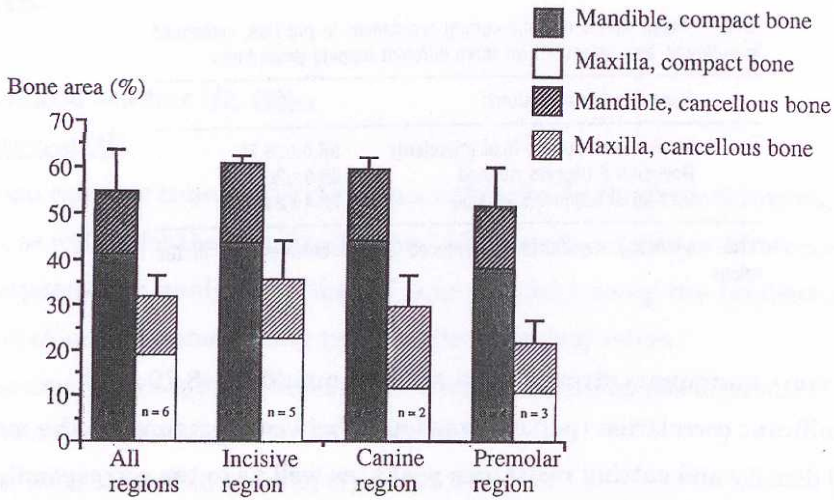

Figure 10. Diagram showing the mean values expressed in percent for total, compact and trabecular bone areas, respectively, of mandibles and maxillae, as well as for different jaw regions (study III).

A significant correlation ($r=0.90$, $p<0.001$) was seen between the bone density and true cutting resistance profiles of each implant site, when the positions of the maximum peaks were measured (Fig. 11).

A significant correlation ($r=0.74$, $p<0.001$) was also seen between values of total bone area and true cutting resistance (Fig. 12).

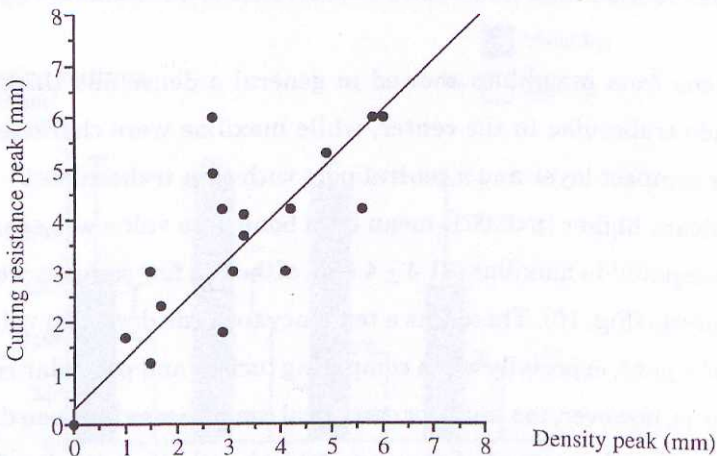

Figure 11. Diagram showing the correlation between peaks of true cutting resistance and bone density of the same site. Eleven sites were recorded at the start of the registration (0 mm)(study III).

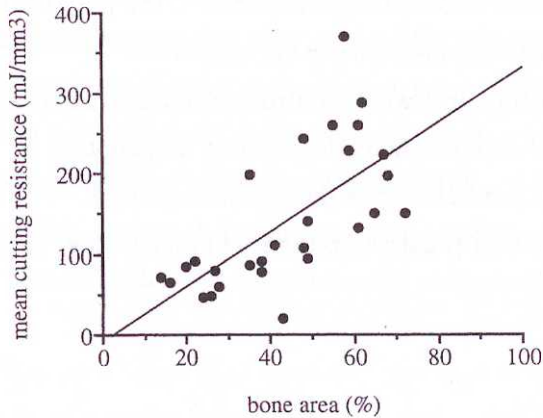

Figure 12. Diagram showing the mean true cutting resistance values of each site correlated with the total bone area of the corresponding site (study III).

Clinical studies (I, IV-VI)

Study I

Out of 4,461 inserted implants, 69 (1.5%) were found mobile in 57 jaws (6.0%) before connection of the prosthetic constructions. Most losses were observed in edentulous maxillae (46/69), and of the losses short 7 mm implants predominated (37/46). Fixtures placed in terminal positions failed to a higher degree (26/536; 4.9%) than in other locations. The corresponding figures for central and intermediate positions were 16/536 (3.0%) and 4/457 (0.9%), respectively. Another 5 implants were lost in partially edentulous maxillae, with no obvious failure pattern concerning size and position.

In mandibles with complete and partial edentulism, 15 and 3 implants were lost, respectively, of which 7 were of the short 7 mm ones. No specific failure location was found in mandibles.

When referring to jaw bone shape, groups D and E, with severe to extreme resorption (Lekholm & Zarb 1985b), showed the highest failure rates for both jaws; 17.4% (23/132) in maxillae and 7.1% (6/85) in mandibles. For 39% of the failures (27/69), there was a statement made in the patient file on either the presence of a bone defect or limited bone volume.

When referring to jaw bone quality, group 4, with poor bone texture (Lekholm & Zarb 1985b), showed the highest failure rate in maxillae: 40.4% (23/57); while group 1, with dense compact bone, represented most failures in mandibles: 13.0% (3/23). For 32%

of the failures (22/69), there was a statement made in the patient file on either lack of initial implant stability or extremely poor bone texture.

The majority of the implants were identified as failures at abutment operation (48/69), while 4 were lost due to infection during healing and another 17 were found mobile after abutment operation but before prostheses connection.

No failure pattern with regard to patient characteristics, such as health, age or gender, was seen.

Study IV

Out of 523 inserted implants, 8 (1.5%) were found mobile in 7 jaws (6.6%) before connection of the prosthetic constructions. Another 18 implants failed during the subsequent 3-year follow-up period, yielding a total loss of 26 implants (5.0%). Most losses were observed in edentulous maxillae (21/26), and of the losses 7 mm standard implants (9/21) and 13 mm Mk II (7/21) predominated. Partially edentulous maxillae were represented with 3 implant losses, while one completely and one partially edentulous mandible each demonstrated one implant failure. With regard to the 420 Mk II implants, of which 412 were subjected to cutting torque measurements during insertion, 14 were lost during the study period (3.3%).

With one fixed prosthesis and one overdenture being lost during the first year, and another fixed prosthesis being removed and replaced by an overdenture during the second year, the prosthesis stability rate of originally inserted constructions ended up on 97.3%.

The altered use of prophylactic antibiotics in the last 35 patients treated, i.e. a reduction from 10 days of administration to a single preoperative dose, was neither connected with an increase in postoperative infections nor an increase in early implant losses.

When referring to jaw bone quality, group 2, with medium bone texture, showed the highest Mk II failure rate: 4.7% (11/236); one failed in bone of group 3 (0.9%); while group 4, with poor bone texture, represented 2.8% (2/72). Of implants others than Mk II, one failed in quality 4: 4.5% (1/22), while 6 and 5 failed in bone of quality 2 and 3, respectively.

Almost all mean values of cutting torque were significantly higher (E1: $p=0.03$; E3: $p=0.003$; E-total: $p=0.004$) in mandibles compared to maxillae, while the corresponding

E2-values were found non-significantly different. A tendency towards declining values from anterior to posterior regions was seen in maxillae, though not in mandibles.

Statistically significant correlations were seen between E1 and bone quality values ($p=0.002$), as assessed according to the Lekholm & Zarb index (1985b), as well as between E2, E3, E-total and bone quality, respectively ($p=0.0001$).

Mean values with standard deviations of the cutting torque obtained for the successful ($n=398$) and failed Mk II implants ($n=14$) were similar.

Study V

Out of the 61 implants inserted (49 Mk II), 2 fixtures (1 Mk II) were found mobile at abutment operation, whereafter no further losses occurred during the study period being 20 months. All the 9 patients studied were provided with fixed prostheses.

When referring to jaw bone quality, 30 sites were assessed as group 4. One implant failed in this bone situation during the study period.

Values of RF and cutting torque (E1, E2, E3 and E-total) were correlated on individual site ($n=47$) as well as on patient level ($n=9$). A relationship between all values was established, though only significant for the patient mean E1- and RF-values ($p=0.036$). Thus, patient mean and individual site E1-values were subjected to further statistical analyses.

Patient mean E1-values were plotted against patient mean difference in RF between implant placement and abutment operation. A significant negative correlation was revealed ($p=0.007$), i.e. the poorer bone texture at implant placement the greater increase in stability of the implant/tissue interface over time.

When analysing the three E1-value categories, comprising 16, 16 and 15 sites, respectively, corresponding to differences in bone resistance at implant placement, mean values (Ncm) with standard deviations were obtained as follows: group 1: 3.4 ± 0.62 ("low bone density"); group 2: 4.5 ± 0.22 ("medium bone density"); and group 3: 6.3 ± 1.18 ("high bone density"). The corresponding figures for RF (Hz) at implant insertion, as well as at abutment operation and at the 1-year follow-up, are presented in Fig. 13.

Significant differences were seen between groups 1 and 2 ($p=0.047$), and groups 1 and 3 ($p=0.002$), respectively, at implant insertion, though not between groups 2 and 3 ($p=0.131$) (Fig. 13). When repeating the analyses for RF values obtained at abutment

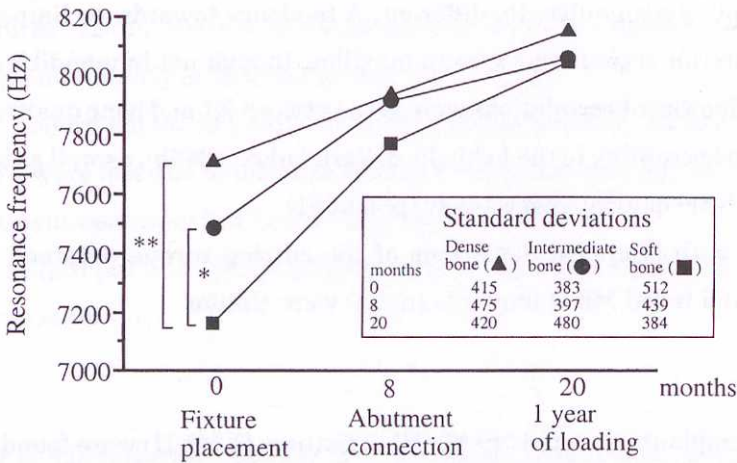

Figure 13. Diagram showing the three groups of implant sites, based on E1-values, plotted against the corresponding resonance frequency values at implant insertion, abutment operation and at first annual check-up (* $p=0.047$, ** $p=0.002$)(study V).

operation and at the first annual check-up, no significant differences were detected between any of the groups.

The mean RF values, obtained for all the MK II implants, increased significantly between implant placement and abutment operation (425 Hz; $p<0.001$), as well as between

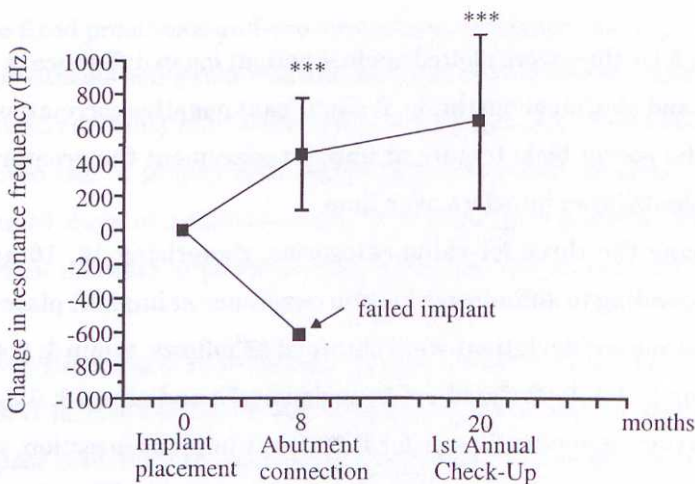

Figure 14. Diagram showing the changes in mean resonance frequency values (with standard deviations) from implant placement to abutment operation and to first annual check-up (***) $p<0.001$). A lowered resonance frequency value of 600 Hz was seen for the failed implant (arrow)(study V).

abutment operation and the 1-year follow-up (225 Hz; $p < 0.001$) (Fig. 14). One Mk II implant was found loose at abutment operation and the RF value was approximately 600 Hz below the corresponding one registered at implant placement (Fig. 14).

The mean marginal bone levels at 8 and 20 months were 0.13 ± 0.20 mm and 1.03 ± 0.29 mm, respectively, below the reference point. The mean marginal bone loss during the first year, thus, was 0.90 ± 0.28 mm.

Study VI

Out of the 75 inserted implants, only one failed during the study period, and therefore all the 15 patients could be provided with fixed prostheses after 15 weeks of healing.

When referring to jaw bone shape, group B, with extensive bone volume, predominated (13/15 patients), while the remaining two patients represented group C.

When referring to jaw bone quality, groups 2 and 3, with medium bone texture, predominated (14/15 patients), while the remaining one patient represented group 4.

A slightly lowered mean value of RF was registered at the 15-week follow-up, which was significantly different ($p = 0.004$) from the value obtained at implant insertion (Fig. 15).

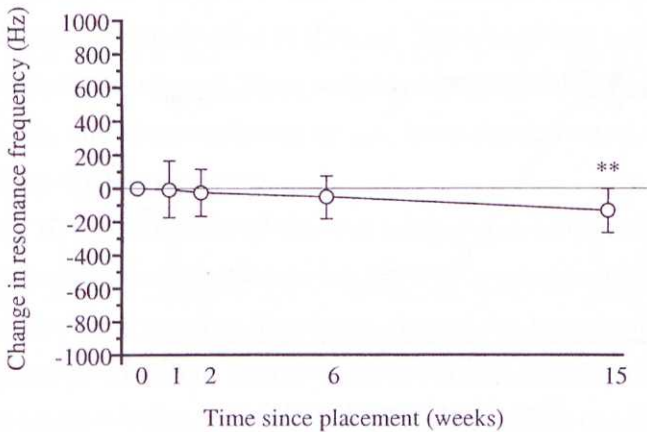

Figure 15. Graph representing the mean change of resonance frequency values (with standard deviations), for all implants throughout the study period (** $p = 0.004$) (study VI).

The RF values of the failed implant were at the 1- and 2-week check-ups similar to the other 4 implants inserted in the same patient, whereas at the 6-week visit, its value dropped by 2,000 Hz. At this time, an excessive marginal bone loss (2-3 mm) was registered radiographically, but the implant was otherwise stable and free of symptoms. First 9 weeks later, the clinical mobility was revealed and the RF value was at this stage further lowered by approximately 300 Hz (Fig. 16).

At the 6 week follow-up, a second patient showed up with 3 implants with decreased RF values, i.e. in the range of 1,000 -1,900 Hz below the corresponding initial values. No clinical signs of failure, such as pain or mobility, were detected. These implants were immediately relieved of preloading from the removable denture and the patient was asked to use the denture at minimum. Nine weeks later, the RF values were either unaltered or slightly increased, and still no signs of clinical mobility were detected. The patient was recalled at 30 weeks, when all the 5 inserted implants were clinically stable and without symptoms. The registered RF values of that visit showed an increase compared to the values obtained at the 15-week assessment.

The mean values of the distance from the implant reference point to the present marginal bone level, did not significantly differ for the 3 implant designs studied at 15 weeks and were found to be 0.65 ± 0.14 mm, 0.66 ± 0.71 mm and 0.38 ± 0.46 mm for self-tapping (conical heads), standard and Mk II implants, respectively.

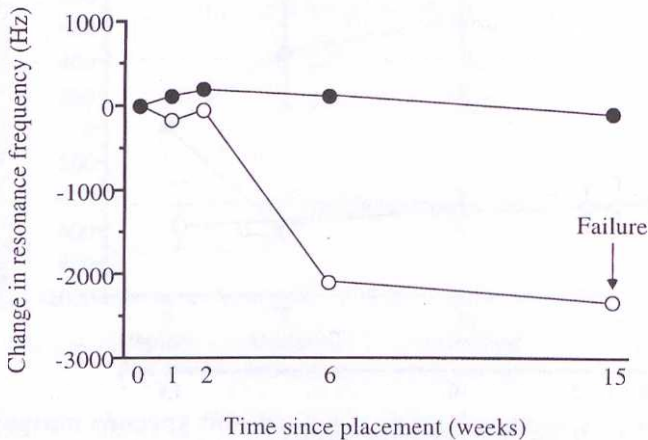

Figure 16. Graphs representing change of resonance frequency values of one failed (white dots) and four successful implants (black dots), of the same patient (study VI).

DISCUSSION

Methodological considerations

In the Johansson & Strid (1994) model, the quality or hardness of bone was revealed during low speed threading by measuring the true cutting resistance, which was obtained by subtracting the friction torque from the total torque. The friction was always found to occur at a part of the screw tap, where the cutting process was already completed. It was seen that the newly cut bone threads were successively worn by the friction portion of the screw tap and the friction torque between a specific bone thread and the tap diminished, as the latter was screwed further into the bone. The authors found, however, a substantial amount of bone material being tightly packed around the tap, exerting a high pressure and resulting in an additional friction between the bone shivers and the bone itself along the cutting portion. While no additional torque related to shiver packing was seen in softer bone, the contribution of the shivers was found to depend linearly for greater bone hardness. In the present studies II and III, this technique was evaluated during threading, using *in vitro* test samples with the effort to obtain similar conditions as described by Johansson & Strid (1994). Thus, the friction torque was subtracted from the total torque, and the remaining true cutting resistance values were used for the subsequent analyses. In studies IV and V, however, mainly self-tapping implants were used with little or no need for threading procedures, and torque values were instead obtained during implant insertion. The *in vivo* primary implant stability was of major concern, and factors contributing to that; i.e. bone hardness and bone shiver packing, were regarded to be of interest. Thus, only the idling speed energy was subtracted from the total torque, and the remaining torque, here denominated cutting torque values, were utilized for further analyses.

In study II, the reliability of the true cutting resistance technique was evaluated. Methodological analyses were executed in pig ribs to test the influence of different hand pressure and deviating tapping directions. A need for homogeneous test samples was therefore at hand and implant furnished sites were analysed with regard to the amount of total, compact and trabecular bone, respectively, within corridors along each side of the sectioned implants. Furthermore, computer calculated positions of density maximum and minimum peaks were established and all measured variables were presented with

mean values, standard deviations and 95% confidence intervals. Homogeneity within a population is statistically difficult to show, though confidence intervals with short ranges indicate such a condition. Based on the morphometric analyses, the samples were regarded acceptably homogeneous and considered adequate for testing of the reliability of the true cutting resistance technique.

The non-significant differences obtained between the true cutting resistance values of the three threading modalities were interpreted as, the technique being neither sensitive to normal differences in hand pressure nor to minor deviations in threading direction. The latter aspect may be explained by the self-acting correction of the threading direction, due to the mobile connection between the screw tap and the connecting piece. Furthermore, registered true cutting resistance values obtained from the two investigators did not differ significantly. Thus, the influence on the outcome of true cutting resistance measurements, due to interindividual differences in surgical performance, was regarded to be negligible.

A possible source of error of the true cutting resistance technique was the cutting ability of individual screw taps, which may have influenced the recorded values. However, Johansson and Strid (1994) tested eight new screw taps (Brånemark System[®]) with regard to equivalence in cutting ability, and the authors showed more or less identical test graphs, when threading in homogeneous materials. In study II, a new screw tap was also used for each of the three threading modalities, while in study III, each of the ten specimens were threaded with a new screw tap. The influence of the taps on the test values were therefore regarded negligible. In study IV and V, cutting torque measurements were conducted during insertion of Mk II implants. A certain deviation in cutting ability of Mk II implants has been demonstrated (Bäck 1999, personal communication), although its impact on registered cutting torque values obtained from various jaw bone textures is considered to be of little importance.

When using the computer software for repeated measurements of the bone area, obtained from microradiographs of the same specimens, reliable and reproducible results were demonstrated. Thus, errors of random were considered to be of little importance.

It may be stated that pig ribs were suitable as test samples when evaluating the true cutting resistance technique. Repeated bone area measurements demonstrated a high precision. The true cutting resistance technique was reliable and registered values were

not influenced by variations in the threading protocol or by interindividual differences.

Cutting torque and bone density measurements

A significant correlation was shown between maximum (lower half of the rib sample) and minimum peaks of density and true cutting resistance, respectively (study II). A similar relationship between obtained cutting resistance values and the radiographic aluminum-referred density was shown by Johansson & Strid (1994), who used bovine bone samples. In the present study, no significant correlation was, however, seen between the maximum (upper half) density and true cutting resistance peaks. A plausible explanation for this outcome may be that the compact bone layer was tangent to and not part of the prepared site of two samples. Therefore, the compact bone may have had an impact on the bone density values, as obtained from the implant corridors, while no such influence on the true cutting resistance values was at hand. A significant correlation between peaks of bone density and true cutting resistance was also shown, when testing the applicability of the true cutting resistance technique in human jaw autopsy specimens, as conducted in study III. This is in agreement with Sugaya (1990), who compared values of cutting torque and the radiographic aluminum-referred bone density in post mortem human jaws. A non-invasive technique to assess the bone density was executed in study IV, using the bone quality index proposed by Lekholm & Zarb (1985b). A significant correlation between bone quality scores (Lekholm & Zarb 1985b) and bone mineral density (BMD), as measured with dual energy X-ray absorptiometry, was established in mandibles by Horner & Devlin (1998a). Thus, the index was used in study IV to assign each implant site a density score, which was plotted against the corresponding cutting torque value of the same site. A significant relationship was demonstrated. Consequently, data from studies II, III and IV have shown, both *in vitro* and *in vivo*, statistically significant correlations between obtained values of true cutting resistance/cutting torque and bone density.

Significant higher mean true cutting resistance values were demonstrated in mandibles as compared to maxillae (study III). Since a significant correlation between values of true cutting resistance and total bone area was established, as well, one conceivable cause for the different values obtained from mandibles and maxillae may be found in the histomorphometric analysis of the same study. While the trabeculae were

normally wider in mandibles, the amount of trabecular bone interfacing with the implants was similar within mandibles and maxillae. The amount of total bone was, however, significantly different, as a result of the more cortical bone seen in mandibles. Consequently, the more and harder the bone the higher the registered torque values, which was also stated by Johansson & Strid (1994). The outcome of the histomorphometric analysis of study III may, as well, facilitate the interpretation of some of the study IV results. In the latter study, the cumulative torque was presented as a mean value for the upper (E1), middle (E2) and lower (E3) third portion, as well as an overall value for the whole implant site (E-total). Significantly higher values of E1, E3 and E-total were demonstrated for mandibles as compared to maxillae, though not, when comparing the E2-values. Since, in the majority of implant sites, E1- and E3-values reflected the resistance of mainly cortical bone in crestal and basal jaw regions, respectively, as well as both these cortical layers had an impact on the E-total-values, mandibles could be expected to exert more resistance than maxillae. However, the E2-values reflected the resistance of mainly trabecular bone, and since similar amounts of trabecular bone were seen in mandibles and maxillae, one plausible explanation to the non-significant difference found between the E2-values was at hand. A second cause for this outcome may be found in connection with the chosen final twist drill diameter. All Mk II sites in maxillae were prepared to a final diameter of 3.0 mm, while all corresponding sites positioned between the mental foramina, were prepared to a final diameter of 3.15 mm. This increase in diameter will reduce the bone resistance in trabecular as well as in cortical passages of the mandibles. The reduction in cortical bone resistance was, however, not sufficient to produce similar E1-, E3- and E-total-values of maxillae and mandibles.

A tendency towards declining cutting torque values in posterior direction was demonstrated for maxillae in both studies III and IV, and a corresponding decrease in total bone area was also shown in study III. The latter is in accordance with the report by Razavi et al (1995), who found histologically increased trabeculation and thicker cortex in the maxillary anterior area, as compared to premolar and molar ones. With regard to mandibles, a similar tendency towards lower cutting torque values in posterior direction was seen in study III, though not established in study IV. A corresponding decrease in total bone area, though not as marked as in maxillae, was also shown in study III. According to von Wowern (1977a), the mandibular trabecular bone was found more dense

and delicately woven in the incisor region, as compared to the premolar one. Furthermore, the trabecular BMD values were significantly higher in anterior compared to posterior sections of mandibles (Lindh et al 1996a). Both latter studies may support the tendency to declining cutting torque values towards posterior regions, as seen in study III. On the other hand, huge variations in trabecular bone volume between mandibles, as well as within sections of mandibles have been demonstrated (von Wowern 1977a, Lindh et al 1997, Ulm et al 1997). This may support the divergent outcome of cutting torque measurements in mandibles, as seen in study IV.

It may be stated that the true cutting resistance/cutting torque technique was applicable to the jaw bone situation both *in vitro* and *in vivo*. Significant correlations between values of bone density and total bone area, respectively, and true cutting resistance were demonstrated. Mandibles displayed more total bone and thus, higher values of cutting torque as compared to maxillae.

Implants and bone quality

It was not possible to identify any lower limit value of cutting torque at which the inserted implants were at risk (study IV). Eleven out of the 14 Mk II implants that failed, were placed in bone judged as quality 2, while one fixture was lost in quality 3. With regard to quality 4 (osteoporosis-like) bone, two out of 72 Mk II implants (2.8%) failed, both being recorded in one maxilla. In 9 maxillae, all sites were judged as quality 4, which revealed a failure rate for such bone in upper jaws of 11.1% (1/9) at 3 years. This is in contrast to the outcome in study I, where 57 maxillae were assigned the quality 4 figure, and 23 of these (40.4%) were involved with implant failures before connection of the prostheses. With regard to mandibles, no losses in quality 4 bone were recorded in study IV, while 2 jaws out of 73 (2.7%) were involved with implant failures in study I. However, differences between the surgical protocols of the two studies were at hand. While in study I, the overall majority of implant sites were completely threaded, or at least the coronal half of sites of low bone density, mainly self tapping Mk II implants were used in study IV. Since threading may have an impact on the primary implant stability obtained in bone of poor texture, with increased risks for rotation or total mobility, the omission of such a procedure has been suggested (Misch 1990, Sennerby 1991, Friberg et al 1992, Friberg 1994a). In a rabbit model, conducted by Ivanoff and coworkers

(1996b), it was also concluded that initial rotation mobility did not lead to inferior integration of unloaded implants, but total mobility resulted in less bone formation around the implants. The authors recommended prolonged healing periods for both situations. In study I, however, healing periods of 6 months (Adell et al 1981) were used for most maxillae, while for the study IV implants placed in bone of low density, an extended healing (8 months) was utilized. Evidence of a time-dependent increase in bone-to-metal contact has been demonstrated histomorphometrically in rabbit bone (Johansson & Albrektsson 1987, Sennerby et al 1992, Ivanoff et al 1996b, Mori et al 1997). An improved implant stability over time, as measured with removal torque, has also been reported (Johansson & Albrektsson 1987, Sennerby et al 1992, Ivanoff et al 1996a). Thus, the omitted threading procedure and the use of prolonged healing periods in study IV, may to a certain extent explain the favourable outcome of Mk II implants in bone of poor texture, as compared to the results obtained from placement of standard implants in study I. Contradictory results are, however, also available in the current literature with regard to implant placement in quality 4 bone. While high failure rates have been reported for implants in such bone situations (Engquist et al 1988, Bass & Triplett 1991, Jaffin & Berman 1991, Jemt 1993, Jemt & Lekholm 1995, Sullivan 1997), encouraging results have been presented by others (Bahat 1993, Venturelli 1996, Friberg et al 1997, Truhlar et al 1997). Successful outcomes of implant treatment have, as well, been demonstrated in patients with established osteoporosis of the jaws (Friberg 1994b, Fujimoto et al 1996, Eder & Watzek 1999).

All posterior non-Mk II sites of quality 4 (additional 22 sites) in study IV, were in general prepared to a final diameter of 3 mm with subsequent insertion of wider diameter implants (4 or 5 mm), in order to improve the primary implant stability. One fixture (10 mm, Ø 4) failed in these sites during the study period of 3 years. In a multicenter study of patients with partial edentulism, a favourable outcome at the 1-year follow-up of 4 mm diameter implants was presented by van Steenberghe et al (1990), which was further confirmed at the 5-year check-up of the same patient material (Lekholm et al 1994). With regard to the 5 mm diameter implants (Langer et al 1993) used in study IV, various results after 1-5 years of function, with higher survival rates in maxillae compared to mandibles, have been reported (Aparicio & Orozco 1998, Ivanoff et al 1999b, Renouard et al 1999).

It may be stated that fixtures placed in bone of quality 4 presented a favourable outcome when being subjected to a modified surgical protocol. By omitting the threading procedure, by using wide diameter implants in standard diameter bone sites and by extending the healing period, the high failure rate in soft bone situations was markedly reduced. Thus, it was not possible to identify a lower limit cutting torque value at which the inserted implants were at risk.

Implants and bone volume

The outcome of study I clearly showed that the overall majority of implant failures was seen in severely resorbed maxillae (shape groups D and E), frequently combined with bone of low density. Thus, 72.5% (37/51) of the registered implant losses in maxillae were 7 mm fixtures. Short implants, as compared to longer ones, have demonstrated higher failure rates in numerous publications (van Steenberghe et al 1990, Bahat 1993, Nevins & Langer 1993, Jemt et al 1996, Wyatt & Zarb 1998). Due to the high number (531 implants) of inserted 7 mm implants in maxillae (study I), the outcome was still favourable with 93% being successfully integrated. Also in mandibles, the 7 mm implants predominated amongst the failures, though more frequently in bone of high density. Thus, 38.9% (7/18) of registered implant losses in mandibles were 7 mm fixtures. Triplett et al (1991) demonstrated, when inserting 7 and 10 mm long fixtures into severely resorbed edentulous mandibles of presumable high density, a somewhat increased failure rate at the one year follow-up of 6.2%. Due to the high number (262 implants) of inserted 7 mm implants in mandibles (study I), the outcome was still favourable with 97.3% being successfully integrated. When considering the outcome of study IV, in which 9 out of the 12 non-Mk II implants that failed were 7 mm long, a reiteration of the higher failure rate seen with short implants was at hand. With regard to Mk II implants, the shortest one used (10 mm), was also associated with the highest failure rate of 5.1% (4/78), although the 13 mm long Mk II implant predominated in number of losses (7 fixtures). In the prospective 3-center study of Mk II implants (Olsson et al 1995), the majority of losses were, as well, associated with the 10 mm long implants after 3 years of function (12.0%). The increased failure rate seen with shorter implants may find its main explanation in the reduced bone-to-implant contact, as compared to longer implants.

In edentulous maxillae, 42 out of 46 failed implants were placed in terminal or

central positions, which roughly concurred with premolar and incisor regions (study I). The low failure rate of implants placed in intermediate positions may be explained by the bone anatomy, which presumably comprised the canine strut with its superior bone support. No similar pattern was seen for early maxillary failures of study IV. With regard to late (after 3 years) implant failures of others than Mk II, 11 out of the 12 losses (all in maxillae) were placed in terminal and central positions, while only one was positioned in the canine region. When considering the Mk II implants in maxillae (study IV), a different outcome was revealed, with 6 out of 12 failures being registered in canine positions. The latter result was influenced by the two complete failures that occurred, comprising 4 implants in canine positions. In mandibles, no typical failure pattern with regard to positions was demonstrated in study I, which may be explained by the rather homogeneous bone volume seen between the mental foramina. In study IV, only two mandibular losses (Mk II implants) were registered during the study period of 3 years.

It may be stated that short implants in maxillae failed to a higher extent than longer ones, irrespective of the surgical protocol used. Maxillary implants in incisor and premolar regions failed more than implants in canine positions. Mandibles did not exhibit typical failure locations.

General remarks on implant results

The obtained early failure rates of implants, i.e. implant losses registered prior to the connection of prostheses, were identical (1.5%) for studies I and IV. The figure compares well with the results of other reports too (Friberg et al 1992, Olsson et al 1995, Sullivan et al 1997). It even exceeds the ones obtained by others (Cox & Zarb 1987, Engquist et al 1988, van Steenberghe et al 1990, Truhlar et al 1997), which becomes more evident, when comparing the figure (1.5%) with the one presented by Esposito et al (1998a). The latter authors used a metanalytic approach, comprising a sample of 16,935 (Brånemark System®), and an early failure rate of 3.6% was presented. One reason for the favourable outcomes of studies I and IV, may be the high number of implants placed at the Brånemark Clinic, which presumably contributed to a good quality and consistent level of treatment.

The majority of failed implants in study I (48/69), and all early failures in study IV (8/8), were diagnosed during the abutment operation. Surprisingly, 17 (14 maxillary) of the study I losses, were considered stable at second stage surgery and yet, they were

found mobile during the prosthetic treatment procedure. It may be hypothesized that the surgeon overloaded the implant and traumatically disrupted the rather weak and newly established osseointegration during abutment operation. Being mechanically tightened deeper into the bone, the implant might have given a false impression of stability. During the subsequent weeks, the compressed bone resorbed and, thus, revealed the implant mobility. Another explanation for the delayed losses could be traumatic overloading due to accidental contacts between implants and opposing teeth during the weeks following abutment operation. Thus, it is important to connect the restorations as soon as possible after abutment operation, thereby protecting the individual implants from accidental overload. In study I, a loss of 4 implants prior to abutment operation was caused by infection (0.09%), while no implants of study IV demonstrated corresponding problems. The altered use of prophylactic antibiotics from 10 days of administration, as executed in study I and for the first 70 patients treated in study IV, to a single one hour preoperative dose, as executed for the last 35 patients included in study IV, was neither afflicted with an increase in postoperative infections nor an increase in the early implant failure rate. While Dent et al (1997) reported on the importance of using preoperative antibiotics to increase the survival rate up to and including second stage surgery, Gynther et al (1998) found no differences between patients with and without antibiotic prophylaxis, with respect to early and late postoperative infection rates or implant survival.

The implant survival rates at 3 years (study IV) of 92.0% and 99.4% for edentulous maxillae and mandibles, respectively, are close to equivalent to the 5-year data reported by Adell et al (1990). The corresponding figures obtained from the prospective 3-center study at 3 years (Olsson et al 1995), were 87.4% and 99.7%, respectively, when figures for Mk II and standard implants were pooled. With regard to partial edentulism (study IV), survival rates of 95.4% and 97.6% for maxillae and mandibles, respectively, have been demonstrated, which compare well with other reports (Bahat 1993, Jemt & Lekholm 1993, Lekholm et al 1994, Wyatt & Zarb 1998, Eckert & Wollan 1998). In study IV, 10 out of 105 patients were involved with implant failures, and out of the 26 losses, 13 (50%) were recorded in two patients, while 21 (80.8%) were diagnosed in 5 patients. This "clustering effect" has been reported on before (Weyant & Burt 1993) and was also found to have a substantial impact on the outcome, as presented by Friberg et al (1997). In the latter study, 9 out of 103 patients were involved with implant failures, and out of the 27

losses, 18 were recorded in 3 patients (66.7%), while 23 (85.2%) were diagnosed in 5 patients.

It may be stated that low early implant failure rates were achieved, irrespective of the surgical protocol used. The majority of early losses were diagnosed at abutment operation. The single dose of preoperative antibiotics was sufficient to maintain low rates of postoperative infections and early implant losses. Failures tended to cluster within few patients.

Cutting torque and resonance frequency measurements

A relationship between obtained values of cutting torque and resonance frequency (RF) at implant placement was found for all E-values in study V. A statistically significant correlation was, however, only found for patient mean E1-values and patient mean RF values. This finding emphasizes the importance of the marginal bone density on implant stability as measured with RF, since the E1-value reflects the bone density of the crestal third of the site. Why the patient mean E1-value, and not the individual site E1-value, showed the closest relationship with RF might be coincidental, or explained by the fact that a mathematical calculation of the mean reduces the variation.

A significant negative correlation was seen between patient mean cutting torque values at the E1-level and change in RF from implant placement to abutment operation, which may be interpreted as the lower values of cutting torque and RF at first stage surgery the greater increase in RF at second stage surgery (study V). This suggests that the tissue response of low density bone was more influential on the secondary implant stability. This relation between bone density and the increase in implant stability over time was further demonstrated by dividing the bone sites into three groups based on the E1-values, which were plotted against the corresponding RF values. Statistically significant differences were seen when comparing groups 1 and 2, and especially, when comparing groups 1 and 3. At abutment operation and at the 1-year follow-up, i.e. 8 and 20 months after implant placement, respectively, no significant differences between the groups were at hand. Thus, implant stability in bone of low density was seen to "catch up" over time with the ones obtained in bone of medium and high densities. The stiffness of the implant/tissue interface was regarded one determinant factor of RF (Meredith et al 1996a), and the change in RF over time was said to reflect the difference in interfacial

stiffness, as a result of bone formation and maturation. Based on the study V results, it may be suggested that a further increase in bone-to-implant contact was more or less important for the implant stability, and this relation seemed to be dependent on the initial bone density present. Consequently, in bone of low density, the increase in bone-to-implant contact as a result of osteogenesis may have had a greater impact on implant stability than the corresponding increase in bone of medium and high density.

It may be stated that a relationship between crestal bone density and primary implant stability was established. With regard to secondary stability, implants inserted in bone of low density approached over time the ones inserted in bone of medium and high density.

Implant stability and duration of healing

When considering the patient mean RF values ($n=9$), a significant increase in implant stability was seen between implant placement and abutment operation, as well as, between abutment operation and the 1-year follow-up (study V). Whether this increase was continuous for the whole study period of 20 months is not known, since measurements were not executed between the abutment operation (8 months) and the 1-year visit (20 months). The bone remodeling effect on implant stability may have been completed already after 9–12 months, which is more in agreement with the findings by Rasmusson et al (1998b). In the latter study implants were placed in two groups of rabbit tibiae, with and without bone grafts, and the RF values increased up to 8-16 weeks after placement. Between 16 and 24 weeks no further change in RF was registered in either of the groups. In rabbits, bone turnover is found somewhat different to humans, and 16 weeks in rabbit bone correspond to 11-13 months in human bone (Roberts et al 1984). However, a progressive tissue response over a long period of time, as suggested in study V, coincides with the view of Brånemark et al (1977), who stated that, after implant insertion, the remodeling period of bone will continue for at least 18 months.

In study VI, patient mean RF values ($n=15$) of mandibular implants slightly decreased (150 Hz) during the study period of 15 weeks. This outcome supports the conclusion of study V that an increase in bone-to-metal contact was found more or less important for the implant stability, and that this relation seemed to be dependent on the initial bone density present. In study VI, the majority of mandibles exhibited bone of high density,

with well defined cortices and dense inner structures. The bone volume also allowed for placement of long implants with presumably high degrees of bone-to-metal contacts. Thus, most of the implant surfaces may have been engaged with supportive bone immediately after placement and additional bone-to-implant contacts, as a result of osteogenesis, did not markedly increase the implant stability.

It may be stated that maxillary implants gained in stability during healing, while anteriorly placed mandibular implants were as stable in the immediate postoperative period as after the recommended healing period of 3 months.

Resonance frequency and marginal bone level changes

Apart from the stiffness of the implant/tissue interface, the height of the implant not being surrounded by bone, was claimed to be a second determinant factor for RF (Meredith et al 1996a). The longer the distance from the transducer to the bone level, the lower the value of RF. A decrease in RF of approximately 250 Hz was found for each one-mm-increase of the correspondent distance (Meredith et al 1996a). Thus, the length of an attached abutment, or loss of marginal bone, will influence the recorded RF value of the corresponding implant. In study VI, it may be assumed that the marginal bone level was situated at the implant reference point (standard and Mk II implants), or 3.5 mm below the reference point (conical head implants) at the time of implant placement. Thus, the observed change in marginal bone level of 0.4-0.7 mm at 15 weeks may explain the lowered (150 Hz) mean RF value from implant placement to the 15 week-registration. With regard to study V, the mean RF value increased significantly (425 Hz) from implant placement to abutment connection. This may be explained by the change in implant/tissue stiffness, since uniform abutments were used (4 mm long) and the change in marginal bone level was assumed to be negligible (0.13 mm). A significant increase (220 Hz) of the mean RF value was also recorded between abutment operation and the 1-year follow-up, despite that a mean marginal bone loss of 0.9 mm had occurred during the same period. Consequently, the change in implant/tissue stiffness seemed to be the most influential factor on the RF values in bone of low density and, yet, of little or no significance in bone of high density.

The radiographic evaluation at bridge insertion (study VI) disclosed similar marginal bone levels, as has previously been reported in other studies of one-stage surgery

procedures (Ericsson et al 1994, Becker et al 1997, Hermans et al 1997). The use of various fixture designs did not reveal any significant differences, which is in accordance with Hermans et al (1997). Consequently, the presence or absence of a fixture/abutment junction had no influence on the marginal bone level 3-4 months after implant placement, which is in contrast to the findings of an experimental investigation executed by Hermann et al (1997). In the Hermans et al (1997) study, however, no such influence could be demonstrated up to 3 years after placement. In a 5-year follow-up study on implants in maxillae, Jemt & Lekholm (1995) found the mean marginal bone levels at conical implants to be at a greater distance from the reference point, as compared to the corresponding values of standard-shaped implants. The conical implants of that study were, however, inserted with the tapered neck portion into the bone, and thus the marginal bone registrations may not be comparable with the ones of study VI.

It may be stated that the observed lowered mean resonance frequency value in mandibles could find an explanation by the mean change in marginal bone levels seen around the corresponding implants. In maxillae, the change in stiffness of the implant/tissue interface, as measured with resonance frequency, was pronounced and the most plausible explanation instead. Implants with and without the fixture/abutment junctions exhibited similar marginal bone levels after 3-4 months.

Resonance frequency as a diagnostic aid

The RF technique proved to be more sensitive in detecting changes in implant stability than the conventional clinical and radiographic techniques. One implant (study VI) exhibited a drastic drop of the RF value from the 2-week to the 6-week registration, in spite of no clinical signs of pain or mobility. The increased bone loss (2-3 mm) seen in relation to the implant at 6 weeks, might only to some extent explain the lowered value of 2,000 Hz, when considering the ratio of 250 Hz/mm reported by Meredith et al (1996a). The RF value indicated a decrease in stiffness of the implant/tissue interface and that the implant was at risk. Nine weeks later the clinical mobility was evident.

In a second patient, values of three implants dropped markedly between 2 and 6 weeks, probably as a result of unfavourable loading from the denture. Based on the experience from the failed implant, the denture was additionally relined in order to avoid a direct contact between the acrylic base and the implants. The patient was also requested

to minimize the use of the prosthesis. During the subsequent weeks, RF values stabilized and even increased slightly. The study period was extended for this patient, and at 6 months after implant placement, a further increase in RF was registered.

It may be stated that implant failures could be predicted, as well as avoided by early detection of low and/or decreasing stability values, when using the RF technique. With regard to implants at risk, efforts should be made to eliminate unfavourable loading and/or to allow for longer healing.

One stage surgery/delayed or immediate loading

Out of the 75 implants inserted in study VI, one implant failed during the study period of 15 weeks, which compares well with the results of other similar reports (Ericsson et al 1994, Bernard et al 1995, Ericsson et al 1997, Hermans et al 1997, Collaert & De Bruyn 1998). Furthermore, the outcome compares well with the ones obtained from studies executing the conventional two-stage procedure (Friberg et al 1992, Olsson et al 1995). A denture-free period of 2 weeks was used in study VI, which may have avoided uncontrolled loading in the early postoperative period. A 10-day denture-free period was used by Randow et al (1999), who reported on patients with edentulous mandibles, in whom permanent fixed constructions were connected within 20 days following implant placement. None of the implants were lost during the follow-up period of 18 months. However, the immediate use of relined dentures has been reported (Henry & Rosenberg 1994, Becker et al 1997). In the mandibular study by Henry & Rosenberg (1994), all implants were successful during the follow-up period of 2 years. In the Becker et al (1997) study, one-stage surgery was performed in upper and lower jaws, revealing success rates at one year of 93.3% and 96.7% for maxillae and mandibles, respectively. A more evenly distributed loading, as exerted by a denture, may be advantageous to patients with a history of bruxism, since grinding on single non-submerged implants in the healing phase may be detrimental. A better and even safer alternative may be the immediate splinting of some implants (Schnitman et al 1990, 1997, Tarnow et al 1997), or all implants (Brånemark et al 1999), when using fixed appliances. In the latter study by Brånemark et al (1999), conducting the novel approach of "the same day teeth", an implant survival rate of 98% after 2 years was demonstrated.

It may be stated that the change of the surgical concept towards the one-stage

approach in anterior mandibles did not reveal any altered rate of early implant failures. Thus, when considering this outcome as well as data from the aforementioned implant stability measurements executed in mandibles, the direct loading concept of implants placed into bone of similar texture may be recommended.

CONCLUSIONS

As the overall conclusion of this thesis it can be stated that jaw bone quality is one most important determinant for implant stability and success. It is therefore considered valuable to have techniques for easy identification of the jaw bone quality of surgical sites during implant placement, as well as for evaluation of implant stability at placement and follow-up. The cutting resistance and resonance frequency techniques currently tested have partly proved to fulfil these requirements. The specific aims thereby being studied have shown:

- An overall early implant failure rate of 1.5% as demonstrated for each of two studies I and IV, and higher failure rates are seen in maxillae as compared to mandibles. When using a standard treatment protocol, maxillary implants in premolar and incisor positions, in connection with limited bone volume and/or poor bone texture, are involved with more losses. Mandibles with bone of limited volume and dense texture represent high failure rates, but do not show any typical failure locations. When using an adapted preparation technique with extended healing periods, no typical early failure patterns of maxillary and mandibular implants with regard to positions, bone volume or bone texture are seen. With regard to late maxillary failures, premolar and incisor positions in connection with bone of limited volume still represent many losses, while no such finding can be demonstrated in bone of poor texture.
- The true cutting resistance technique to be a reliable method, insensitive to differences in hand pressure and tapping directions, as well as to different investigators. A significant correlation can also be seen between values of true cutting resistance and bone density measurements of homogeneous pig rib samples.
- In vitro values of true cutting resistance and total bone area to be higher in mandibles as compared to maxillae, with a tendency towards decreasing values posteriorly in both jaws. Significant correlations are demonstrated between values of true cutting resistance and bone density measurements, as well as between true cutting resistance and total bone area calculations of post mortem human jaws. The true cutting resistance technique

has also proved to be applicable to clinical investigations.

- Clinical values of cutting torque, obtained from mandibles, to be in general higher than the corresponding ones, obtained from maxillae. A tendency towards decreasing values posteriorly can be seen in maxillae, though not in mandibles. A significant correlation is present between values of cutting torque and assessed bone density scores in vivo. Successful and failed implants present similar values of cutting torque and, thus, a lower limit value at which implants are at risk can not be defined.

- A significant correlation between patient mean cutting torque values of the crestal bone and corresponding resonance frequencies. Implants inserted in bone of various densities exhibit different initial stability, as measured with resonance frequency. The increase in resonance frequency during healing and the subsequent period of follow-up is more pronounced for implants placed in bone of low density, and such implants seem to "catch up" with the ones placed in bone of medium to high density by time.

- Implants placed in anterior mandibles to demonstrate no increase in stability during healing, as measured with resonance frequency. The rather lowered patient mean resonance frequency value seen at the end of study period, may be explained by the observed change in marginal bone level. It is suggested that implant failures can be predicted and even avoided by early detection of low and/or decreasing values of resonance frequency. One-stage surgery, as executed in anterior mandibles, exhibits similar favourable implant outcome at 3-4 months as the conventional two-stage technique. A change in the surgical concept towards direct loading seems possible to recommend for implants placed in favourable bone qualities.

CLINICAL IMPLICATIONS

The results of this thesis indicate that the clinical use and understanding of cutting torque measurements may still be somewhat limited, though registered cutting torque values may help the clinician to determine the extension of healing. The rather recent use of the one-stage surgery concept with delayed or immediate loading, makes the cutting torque technique useful in guiding the surgeon whether fixtures can be loaded directly or not. However, the interpretation of obtained data is difficult, since no lower limit value has been identified and, thus, no information is available regarding the possibility to predict failure or success. The objective measure of the bone texture is determined first during low speed threading or implant placement, which may be disadvantageous. Instead this information should be offered to the surgeon before finalizing the implant site preparation, as such data may be useful when coordinating the final drill and implant diameters to achieve the best primary implant stability. The use of a screw tap diameter of 2.7 mm for collecting cutting torque data may be found useful in this respect.

Regarding the clinical use of resonance frequency measurements, this technique also seems to have some limitations, mainly due to that technical improvements of the device still are undertaken. Nevertheless, the resonance frequency analysis has proven to be useful in conjunction with implant placement. Obtained values of resonance frequency may e.g. help to predict which implants are at risk, and by using appropriate measures (load relief, extended healing) it may help to avoid implant failures. In conjunction with the use of the one-stage surgery concept, with implants being accessible to measurements after placement, the resonance frequency technique appears even more attractive, as it may participate in the decision of performing direct loading and may detect declining implant stability during healing or early function.

The outcome of this thesis also imply a need for recommendations how to clinically handle special bone situations. In addition to data obtained from preoperative radiographs, three major clinical signs of poor bone quality/implant instability may be identified during implant placement:

Despite a low pre-set motor torque (20 Ncm), the bone may not offer sufficient resistance to bring about an automatic stop of the motor when the implant has reached its final position. Such an implant may still be kept in the bone site, though an extended

healing period of 1-2 months is recommended, i.e. 4-5 months and 8 months in mandibles and maxillae, respectively.

During cover screw tightening, the force exerted by the manual screw driver may be sufficient to rotate the implant as well. Such an implant may still be kept in the bone site, though an extended healing period of 2-3 months is recommended, i.e. 5-6 months and 9 months in mandibles and maxillae, respectively.

After implant insertion, the fixture mount (being properly connected to the implant) may be moved horizontally or vertically, indicating a total implant mobility. Such an implant ought to be removed and preferably be replaced by a wider implant. As an alternative after removing the implant, a rongeur may be used for collecting bone shivers to be packed into the walls of the site, allowing the previously used implant to be reinserted and to encounter more resistance. Such an implant may still be kept in the bone site, though an extended healing period of 3-4 months is recommended, i.e. 6 months and 10 months in mandibles and maxillae, respectively.

In sites of poor bone texture, as frequently seen in posterior maxillae, an adapted preparation technique, in conjunction with implant diameter variations, is recommended. The twist drill diameter 3.0 mm and the short-peg countersink are the final drills to be used, when inserting implants of diameters 4.0 and 5.0 mm. The short-peg countersink will thereby allow for a widening of the implant entrance to provide accommodation for the 5.0 mm diameter implant. In bone of less bucco-palatal/lingual width, the use of final twist drill diameters 2.7 or 2.85 mm are recommended, with subsequent insertion of standard diameter implants (3.75 mm). Generous healing periods as described above are in general strongly advised in connection to soft bone situations.

ACKNOWLEDGEMENTS

I wish to convey my sincere appreciation and gratitude to:

Lars Sennerby for introducing me into the field of experimental research, for his never failing support, good advice and excellent guidance throughout the work with this thesis.

Ulf Lekholm for initiating this project and for introducing me into the field of clinical research, for always being there when needed and for his excellent guidance throughout the years.

Tomas Albrektsson for clever remarks, genuine support and for creating a warm, humorous and stimulating atmosphere at his department.

Karl-Gustav Strid, Patrik Johansson and Neil Meredith for sharing their inventions with me.

Tomas Bäck for making research data understandable.

Christina Bergström, Kerstin Gröndahl, Torsten Jemt, Bengt Linden and Johan Roos for their valuable assistance as co-authors.

All staff at the Brånemark Clinic, especially the nurses at "charken".

Librarian Karin Darle-Olsson at the Nobel Biocare AB for helping me obtain valuable scientific papers.

Johan Roos for his contribution to the lay-out.

Lena, Calle, Emma and Erik for understanding a husband and a father, who has lately been more often physically present, although his thoughts have been far away .

This work has been supported by grants from the Greta and Einar Asker Foundation for Medical Research, the Wilhelm and Martina Lundgren Research Foundation, the Swedish Medical Research Council, the Eivind and Elsa K:son Sylvan Foundation, the Faculty of Odontology, University of Göteborg, the Brånemark Clinic, Dental Health Care Göteborg, Nobel Biocare AB, Göteborg, Sweden.

REFERENCES

- Adachi JD. Alendronate for osteoporosis. Safe and efficacious nonhormonal therapy. *Can Fam Physician* 1998; 44: 327-332.
- Adell R, Lekholm U, Rockler B, Brånemark P-I. A 15-year study of osseointegrated implants in the treatment of the edentulous jaw. *Int J Oral Surg* 1981; 10: 387-416.
- Adell R, Lekholm U, Gröndahl K, Brånemark P-I, Lindström J, Jacobsson M. Reconstruction of severely resorbed edentulous maxillae using osseointegrated fixtures in immediate autogenous bone grafts. *Int J Oral Maxillofac Impl* 1990; 5: 233-246.
- Adell R, Eriksson B, Lekholm U, Brånemark P-I, Jemt T. A long-term follow-up study of osseointegrated implants in the treatment of totally edentulous jaws. *Int J Oral Maxillofac Impl* 1990; 5: 347-359.
- Albrektsson T, Zarb GA, Worthington P, Eriksson AR. The long-term efficacy of currently used dental implants: a review and proposed criteria of success. *Int J Oral Maxillofac Impl* 1986; 1: 11-25.
- Albrektsson T. A multicenter report on osseointegrated oral implants. *J Prosthet Dent* 1988; 60: 75-84.
- Alhava EM. Bone density measurements. *Calcif Tissue Int* 1991; (Suppl); 49: S21-S23.
- Andersson L, Kurol M. CT scan prior to installation of osseointegrated implants in the maxilla. *Int J Oral Maxillofac Surg* 1987; 16: 50-55.
- Andersson J-E, Svartz K. CT-scanning in the preoperative planning of osseointegrated implants in the maxilla. *Int J Oral Maxillofac Surg* 1988; 17: 33-35.
- Antich PP, Pak CYC, Gonzales J, Anderson J, Sakhaee K, Rubin C. Measurement of intrinsic bone quality in vivo by reflection ultrasound: Correction of impaired quality with slow-release sodium fluoride and calcium citrate. *J Bone Min Res* 1993; 8: 301-311.
- Aparicio C. The use of the Periotest Value as the initial success criteria of an implant: 8-year report. *Int J Periodont Rest Dent* 1997; 17: 151-161.
- Aparicio C, Orozco P. Use of 5-mm-diameter implants: Periotest® values related to a clinical and radiographic evaluation. *Clin Oral Impl Res* 1998; 9: 398-406.
- Arvidsson K, Bystedt H, Frykholm A, von Konow L, Lothigius E. Five-year prospective follow-up report of the Astra Tech Dental Implant System in the treatment of edentulous mandibles. *Clin Oral Impl Res* 1998; 9: 225-234.
- Aspenberg P, Albrektsson T, Thorngren KG. Local application of growth-factor IGF-1 to healing bone. Experiments with a titanium chamber in rabbits. *Acta Orthop Scand* 1989; 60(5): 607-610.

Atwood DA. Postextraction changes in the adult mandible as illustrated by microradiographs of midsagittal sections and serial cephalometric roentgenograms. *J Prosthet Dent* 1963; 13: 810-824.

Atwood DA. Reduction of residual ridges: A major oral disease entity. *J Prosthet Dent* 1971a; 26: 266-279.

Atwood DA, Coy WA. Clinical, cephalometric, and densitometric study of reduction of residual ridges. *J Prosthet Dent* 1971b; 26: 280-295.

Bahat O. Treatment planning and placement of implants in the posterior maxillae: Report of 732 consecutive Nobelpharma implants. *Int J Oral Maxillofac Impl* 1993; 8: 151-161.

Bass SL, Triplett RG. The effects of preoperative resorption and jaw anatomy on implant success. A report of 303 cases. *Clin Oral Impl Res* 1991; 2: 193-198.

Becker W, Lynch SE, Lekholm U, Becker BE, Caffesse R, Donath K. A comparison of ePTFE membranes alone or in combination with platelet-derived growth factors and insulin-like growth factor-1 or demineralized freeze-dried bone in promoting formation around immediate extraction socket implants. *J Periodontol* 1992; 63: 929-940.

Becker W, Becker BE, Caffesse R. A comparison of demineralized freeze-dried bone and autologous bone to induce bone formation in human extraction sockets. *J Periodontol* 1994; 65: 1128-1133.

Becker W, Urist MR, Tucker LM, Becker BE, Ochsenbein C. Human demineralized freeze-dried bone: Inadequate induced bone formation in athymic mice. A preliminary report. *J Periodontol* 1995; 66: 822-828.

Becker W, Urist M, Becker BE, Jackson W, Parry DA, Bartold M, Vincenzzi G, De Georges D, Niederwanger M. Clinical and histologic observations of sites implanted with intraoral autologous bone grafts or allografts. 15 human case reports. *J Periodontol* 1996; 67: 1025-1033.

Becker W, Becker BE, Israelson H, Lucchini JP, Handelsman M, Ammons W, Rosenberg E, Rose L, Tucker LM, Lekholm U. One-step surgical placement of Brånemark implants: A prospective multicenter clinical study. *Int J Oral Maxillofac Impl* 1997; 12: 454-462.

Benson BW, Prihoda TJ, Glass BJ. Variations in adult cortical bone mass as measured by a panoramic mandibular index. *Oral Surg Oral Med Oral Pathol* 1991; 71: 349-356.

Berman CL. Complications. Prevention, Recognition, Treatment. *Dental Clinics North Amer* 1989; 33: 635-663.

Bernard JP, Belser UC, Martinet J-P, Borgis SA. Osseointegration of Brånemark fixtures using a single-step operating technique. A preliminary prospective one-year study in the edentulous mandible. *Clin Oral Impl Res* 1995; 6: 122-129.

Bessho K, Carnes DL, Cavin R, Chen H-Y, Ong JL. BMP stimulation of bone response adjacent to titanium implants in vivo. *Clin Oral Impl Res* 1999; 10: 212-218.

Bill JS, Reuther JF, Dittman W, Kubler N, Meier JL, Pistner H et al. Stereolithography in oral and maxillofacial operation planning. *Int J Oral Maxillofac Surg* 1995; 24: 98-103.

Block MS, Almerico B, Crawford C, Gardiner D, Chang A. Bone response to functioning implants in dog mandibular alveolar ridges augmented with distraction osteogenesis. *Int J Oral Maxillofac Impl* 1998; 13: 342-351.

Blomqvist JE, Alberius P, Isaksson S. Retrospective analysis of one-stage maxillary sinus augmentation with endosseous implants. *Int J Oral Maxillofac Impl* 1996; 11: 512-521.

Blomqvist JE, Alberius P, Isaksson S. Sinus inlay bone augmentation: Comparison of implant positioning after one- or two-staged procedures. *J Oral Maxillofac Surg* 1997; 55: 804-810.

Blomqvist JE. Aspects of maxillary sinus reconstruction with endosseous implants. Thesis. *Swedish Dental Journal* 1998; Suppl 130.

Bostrom MPG, Aspenberg P, Jeppsson C, Salvati EA. Enhancement of bone formation in the setting of repeated tissue deformation. *Clin Orthop* 1998; no 350; 221-228.

Boyne PJ, Marx RE, Nevins M, Triplett G, Lazaro E, Lilly LC, Alder M, Nummikowski P. A feasibility study evaluating rhBMP-2/absorbable collagen sponge for maxillary sinus floor augmentation. *Int J Periodont Rest Dent* 1997; 17: 11-25.

Breine U, Brånemark P-I. Reconstruction of alveolar jaw bone. An experimental and clinical study of immediate and preformed autologous bone grafts in combination with osseointegrated implants. *Scand J Plast Reconstr Surg* 1980; 14: 23-48.

Brunski JB. Review paper. Biomechanical factors affecting the bone-dental implant interface. *Clin Mater* 1992; 10: 153-201.

Bryant SR. The effects of age, jaw site, and bone condition on oral implant outcomes. *Int J Prosthodont* 1998; 11(5): 470-490.

Brånemark P-I, Hansson BO, Adell R, Breine U, Lindström J, Hallen O, Öhman A. Osseointegrated implants in the treatment of the edentulous jaw. Experience from a 10-year period. *Scand J Plast Reconstr Surg* 1977; II: Suppl 16.

Brånemark P-I, Adell R, Albrektsson T, Lekholm U, Lindström J, Rockler B. An experimental and clinical study of osseointegrated implants penetrating the nasal cavity and maxillary sinus. *J Oral Maxillofac Surg* 1984; 42: 497-505.

Brånemark P-I, Zarb GA, Albrektsson T, eds.: *Tissue-Integrated Prostheses: Osseointegration in Clinical Dentistry*. Chicago: Quintessence Publishing Co, 1985.

Brånemark P-I, Engstrand P, Öhrnell L-O, Gröndal K, Nilsson P, Hagberg K, Darle C, Lekholm U. Brånemark Novum®: A new treatment concept for rehabilitation of the edentulous mandible. Preliminary results from a prospective clinical follow-up study. *Clin Impl Dent Rel Res* 1999; 1: 2-16.

Buckingham SHW, Jeffcott LB, Anderson GA, McCartney RN. In vivo measurement of bone quality in the horse: estimates of precision for ultrasound velocity measurement and single photon absorptiometry. *Med & Biol, Eng & Comp* 1992; 30: 41-45.

Buser D, Weber HP, Brägger U, Balsiger C. Tissue integration of one-stage ITI implants: 3-year results of a longitudinal study with hollow-cylinder and hollow-screw implants. *Int J Oral Maxillofac Impl* 1991; 6: 405-412.

Buser D, Dahlin C, Schenk RK. *Guided bone regeneration in implant dentistry*. Chicago: Quintessence Publishing Co, Inc; ISBN 0-86715-249-4, 1994: 31-100.

Buser D, Mericske-Stern R, Bernard JP, Behneke A, Behneke N, Hirt HP, Belser UC, Lang NP. Long-term evaluation of non-submerged ITI implants. Part 1: 8-year life table analysis of a prospective multi-center study with 2359 implants. *Clin Oral Impl Res* 1997; 8: 161-172.

Cawood JI, Howell RA. A classification of the edentulous jaws. *Int J Oral Maxillofac Surg* 1988; 17: 232-236.

Chamay A, Tschantz P. Mechanical influences in bone remodeling. Experimental research on Wolff's law. *J Biomechanics* 1972; 5: 173-180.

Clelland NC, Lee JK, Bimbenet OC, Gilat A. Use of an axisymmetric finite element method to compare maxillary bone variables for a loaded implant. *J Prosthodont* 1993; 2: 183-189.

Collaert B, De Bruyn H. Comparison of Brånemark fixture integration and short-term survival using one-stage or two-stage surgery in completely and partially edentulous mandibles. *Clin Oral Impl Res* 1998; 9: 131-135.

Compston JE. Review. Osteoporosis. *Clin Endocrinol* 1990; 33: 653-682.

Cortellini P, Bowers GM. Periodontal regeneration of intrabony defects: An evidence-based treatment approach. *Int J Periodont Rest Dent* 1995; 15: 128-145.

Corten FG, van't Hof MA, Buijs WC, Hoppenbrouwers P, Kalk W, Corstens FH. Measurements of mandibular bone density ex vivo and in vivo by dual-energy X-ray absorptiometry. *Arch Oral Biol* 1993; 38(3): 215-219.

Cox JF, Zarb GA. The longitudinal clinical efficacy of osseointegrated dental implants: A 3-year report. *Int J Oral Maxillofac Impl* 1987; 2: 91-100.

Dao TT, Anderson JD, Zarb GA. Is osteoporosis a risk factor for osseointegration of dental implants? *Int J Oral Maxillofac Impl* 1993; 8: 137-144.

Denissen H, Verhey H, de Blicck J, Corten F, Klein C, van Lingen A. Dual X-ray absorptiometry for alveolar bone: precision of peri-implant mineral measurements *ex vivo*. *J Periodontal Res* 1996; 31(4): 265-270.

Dent D, Olson J, Farish S, Bellome J, Casino A, Morris H, Ochi S. The influence of preoperative antibiotics on success of endosseous implants up to and including stage II surgery: A study of 2,641 implants: *J Oral Maxillofac Surg* 1997; 55: 19-24.

Derhami K, Wolfaardt JF, Dent M, Faulkner G, Grace M. Assessment of the Periotest device in baseline mobility measurements of craniofacial implants. *Int J Oral Maxillofac Impl* 1995; 10: 221-229.

Devge C, Tjellström A, Nellström H. Magnetic resonance imaging in patients with dental implants: A clinical report. *Int J Oral Maxillofac Impl* 1997; 12: 354-359.

Donath K, Breuner G. A method for the study of undecalcified bones and teeth with attached soft tissues. *J Oral Pathol* 1982; 11: 318-326.

Donovan MG, Dickerson NC, Hanson LJ, Gustafson RB. Maxillary and mandibular reconstruction using calvarial bone grafts and Brånemark implants. A preliminary report. *J Oral Maxillofac Surg* 1994; 52: 588-594.

Dougherty G. Quantitative CT in the measurements of bone quantity and bone quality for assessing osteoporosis. *Med Eng Phys* 1996; 18(7): 557-568.

Doyle M, Rabin H, Suri J. Fractal analysis as a means for the quantification of intramandibular trabecular bone loss from dental radiographs. *Biostereometric Tech Appl* 1990; 1380: 227-235.

Duckmanton NA, Austin BW, Lechner SK, Klineberg IJ. Imaging for predictable maxillary implants. *Int J Prosthodont* 1994; 7(1): 77-80.

Eckerdal O, Kvint S. Presurgical planning for osseointegrated implants in the maxilla. A tomographic evaluation of available bone and morphological relations in the maxilla. *Int J Oral Maxillofac Surg* 1986; 15: 722-726.

Eckert S, Wollan P. Retrospective review of 1,170 endosseous implants placed in partially edentulous jaws. *J Prosthet Dent* 1998; 79: 415-421.

Eder A, Watzek G. Treatment of a patient with severe osteoporosis and chronic polyarthritis with fixed implant-supported prosthesis: A case report. *Int J Oral Maxillofac Impl* 1999; 14: 587-590.

Engquist B, Bergendal T, Kallus T, Linden U. A retrospective multicenter evaluation of osseointegrated implants supporting overdentures. *Int J Oral Maxillofac Impl* 1988; 3: 129-134.

Ericsson I, Randow K, Glantz P-O, Lindhe J, Nilner K. Clinical and radiographic features of submerged and nonsubmerged titanium implants. *Clin Oral Impl Res* 1994; 5: 185-189.

Ericsson I, Randow K, Nilner K, Petersson A. Some clinical and radiographical features of submerged and non-submerged titanium implants. A 5-year follow-up study. *Clin Oral Impl Res* 1997; 8: 422-426.

Esposito M, Hirsch J-M, Lekholm U, Thomsen P. Biological factors contributing to failures of osseointegrated oral implants. (I). Success criteria and epidemiology. *Eur J Oral Sci* 1998a; 106: 527-551.

Esposito M, Hirsch J-M, Lekholm U, Thomsen P. Biological factors contributing to failures of osseointegrated oral implants. (II). Etiopathogenesis. *Eur J Oral Sci* 1998b; 106: 721-764.

Flora L, Hassing GS, Parfitt AM, Villanueva AR. Comparative skeletal effects of two diphosphonates in dogs. *Metab Bone Dis Relat Res* 1980; 2(Suppl): 389-407.

Friberg B, Gröndahl K, Lekholm U. A new self-tapping Brånemark implant: clinical and radiographic evaluation. *Int J Oral Maxillofac Impl* 1992; 7: 80-85.

Friberg B. Bone quality evaluation during implant placement. Academic dissertation for the degree of master of dental science. University of Göteborg, Göteborg, Sweden. 1994a.

Friberg B. Treatment with dental implants in patients with severe osteoporosis. A case report. *Int J Periodont Rest Dent* 1994b; 14: 349-353.

Friberg B, Nilsson H, Olsson M, Palmquist C. Mk II: the self-tapping Brånemark implant: 5-year results of a prospective 3-center study. *Clin Oral Impl Res* 1997; 8: 279-285.

Fujimoto T, Niimi A, Nakai H, Ueda M. Osseointegrated implants in a patient with osteoporosis: A case report. *Int J Oral Maxillofac Impl* 1996; 11: 539-542.

Greenfield MA. Current status of physical measurements of the skeleton. *Med Phys* 1992; 19: 1349-1357.

Grynepas MD, Holmyard D. Changes in quality of bone mineral on aging and in disease. *Scanning Microsc* 1988; 2(2): 1045-1054.

Gröndahl K, Ekestubbe A, Gröndahl HG, Johnsson T. Reliability of hypocycloidal tomography for the evaluation of the distance from the alveolar crest to the mandibular canal. *Dentomaxillofac Radiol* 1991; 19: 200-204.

Gröndahl K, Ekestubbe A, Gröndahl HG. Radiography in Oral Endosseous Prosthetics. Publ. Nobel Biocare AB, P.O. Box 5190, S-402 26 Göteborg, Sweden 1996: ISBN 91-630-4471-4.

Gröndal K, Lekholm U. The predictive value of radiographic diagnosis of implant instability. *Int J Oral Maxillofac Impl* 1997; 12: 59-64.

Gynther GW, Köndell P-Å, Moberg L-E, Heimdahl A. Dental implant installation without antibiotic prophylaxis. *Oral Surg Oral Med Oral Pathol Oral Radiol Endod* 1998; 85: 509-511.

Hailey D, Sampietro-Colom L, Marshall D, Rico R, Granados A, Asua J. The effectiveness of bone density measurements and associated treatments for prevention of fractures. *Int J Tech Assessm Health Care* 1998; 14(2): 237-254.

Hans D, Fuerst T, Lang T, Majumdar S, Lu Y, Genant HK, Glüer C. How can we measure bone quality? *Bailliere's Clin Rheum* 1997; 11: 495-515.

Henry P, Rosenberg I. Single-stage surgery for rehabilitation of the edentulous mandible: Preliminary results. *Impl Report* 1994; 6: 15-22.

Henry P, Laney WR, Jemt T, Harris D, Krogh P, Polizzi G, Zarb GA, Herrmann I. Osseointegrated implants for single-tooth replacement: A prospective 5-year multicenter study. *Int J Oral Maxillofac Impl* 1996; 11: 450-455.

Heo SJ, Sennerby L, Odersjö M, Granström G, Tjellström A, Meredith N. Stability measurements of craniofacial implants by means of resonance frequency analysis. A clinical pilot study. *J Laryngol Otol* 1998; 112: 537-542.

Hermann JS, Cochran DL, Nummikoski PV, Buser D. A radiographic evaluation of unloaded nonsubmerged and submerged implants in the canine mandible. *J Periodontol* 1997; 68: 1117-1130.

Hermans M, Durdu F, Herrmann I, Malevez C. The applicability of a one step operative technique a.m. Brånemark. A preliminary prospective study in the edentulous mandible. The 6th International Symposium on Periodontics & Restorative Dentistry, June 5-8, 1997, Westin Hotel, Boston, MA, USA (poster presentation).

Hessling KH, Neukam FW, Scheller H, Günay H, Schmelzeisen R. Die extreme Atrophie des Ober- und Unterkiefers: Klinische Gesichtspunkte bei der Versorgung mit endossalen Implantaten. *Z Zahnärztl Implantol* 1990; 6: 35-39.

Hirschmann PH. Magnetic resonance imaging: a possible alternative to CT prior to dental implants. *Br Dent J* 1998; 184: 603-607.

Horner K, Devlin H. The relationships between two indices of mandibular bone quality and bone mineral density measured by dual energy X-ray absorptiometry. *Dentomaxillofac Radiol* 1998a; 27(1): 17-21.

Horner K, Devlin H. The relationship between mandibular bone mineral density and panoramic radiographic measurements. *J Dent* 1998b; 26(4): 337-343.

Hoshaw SJ, Brunski JB, Cochran GVB. Mechanical loading of Brånemark implants affects interfacial bone modeling and remodeling. *Int J Oral Maxillofac Impl* 1994; 9: 345-360.

Ilizarov GA. The tension-stress effect on the genesis and growth of tissues: Part I. The influence of stability of fixation and soft-tissue preservation. *Clin Orthop* 1989a; 238: 249-281.

Ilizarov GA. The tension-stress effect on the genesis and growth of tissues: Part II. The influence of the rate and frequency of distraction. *Clin Orthop* 1989b; 239: 263-285.

Isaksson S. Evaluation of three bone grafting techniques for severely resorbed maxillae in conjunction with immediate endosseous implants. *Int J Oral Maxillofac Impl* 1994; 9: 679-688.

Isidor F. Loss of osseointegration caused by occlusal load of oral implants. A clinical and radiographic study in monkeys. *Clin Oral Impl Res* 1996; 7: 143-152.

Ivanoff C-J, Sennerby L, Lekholm U. Influence of mono- and bicortical anchorage on the integration of titanium implants. A study in the rabbit tibia. *Int J Oral Maxillofac Surg* 1996a; 25: 229-235.

Ivanoff C-J, Sennerby L, Lekholm U. Influence of initial implant mobility on the integration of titanium implants. An experimental study in rabbits. *Clin Oral Impl Res* 1996b; 7: 120-127.

Ivanoff C-J, Sennerby L, Johansson C, Rangert B, Lekholm U. Influence of implant diameters on the integration of screw implants. An experimental study in rabbits. *Int J Oral Maxillofac Surg* 1997; 26: 141-148.

Ivanoff C-J, Gröndal K, Bergström C, Lekholm U, Brånemark P-I. Influence of bicortical or monocortical anchorage on maxillary implant stability. A 15-year retrospective study of Brånemark System implants. *Int J Oral Maxillofac Impl* 1999a; accepted for publication.

Ivanoff C-J, Gröndahl K, Sennerby L, Bergström C, Lekholm U. Influence of variations in implant diameters: A 3- to 5-year retrospective clinical report. *Int J Oral Maxillofac Impl* 1999b; 14: 175-182.

Ivanoff C-J. On surgical and implant related factors influencing integration and function of titanium implants. Experimental and clinical aspects. Thesis. Department of Biomaterials/Handicap Research, Göteborg University, Göteborg, Sweden. 1999c.

Jacobs R, Ghyselen J, Koninckx P, van Steenberghe D. Long-term bone mass evaluation of mandible and lumbar spine in a group of women receiving hormone replacement therapy. *Eur J Oral Sci* 1996; 104(1): 10-16.

- Jaffin RA, Berman CL. The excessive loss of Brånemark fixtures in type IV bone: A 5-year analysis. *J Periodont* 1991; 62: 2-4.
- Jeffcoat MK. Osteoporosis: a possible modifying factor in oral bone loss. *Ann Periodontol* 1998; 3(1): 312-321.
- Jemt T. Failures and complications in 391 consecutively inserted fixed prostheses supported by Brånemark implants in edentulous jaws: A study of treatment from the time of prosthesis placement to the first annual checkup. *Int J Oral Maxillofac Impl* 1991; 6: 270-276.
- Jemt T. Implant treatment in resorbed edentulous upper jaws. A three-year follow-up study on 70 patients. *Clin Oral Impl Res* 1993; 4: 187-194.
- Jemt T, Lekholm U. Oral implant treatment in posterior partially edentulous jaws: A 5-year follow-up report. *Int J Oral Maxillofac Impl* 1993; 8: 635-640.
- Jemt T, Pettersson P. A 3-year follow-up study on single implant treatment. *J Dent* 1993; 21: 203-208.
- Jemt T, Lekholm U. Implant treatment in edentulous maxillae: a 5-year follow-up report on patients with different degrees of jaw resorption. *Int J Oral Maxillofac Impl* 1995; 10: 303-311.
- Jemt T, Chai J, Harnett J, Heath MR, Hutton JE, Johns RB, McKenna S, McNamara DC, van Steenberghe D, Taylor R, Watson RM, Herrmann I. A 5-year prospective multi-center follow-up report on overdentures supported by osseointegrated implants. *Int J Oral Maxillofac Impl* 1996; 11: 291-298.
- Jemt T, Lekholm U. Measurements of bone and frame-work deformations induced by misfit of implant superstructures. A pilot study in rabbits. *Clin Oral Impl Res* 1998; 9: 272-280.
- Jemt T, Bäck T, Pettersson A. Precision of CNC-milled titanium frameworks for implant treatment in the edentulous jaw. *Int J Prosthodont* 1999; 12: 209-215.
- Jensen J, Sindet-Pedersen S. Autogenous mandibular bone grafts and osseointegrated implants for reconstruction of the severely atrophied maxilla. A preliminary report. *J Oral Maxillofac Surg* 1991; 49: 1277-1287.
- Jensen J, Sindet-Pedersen S, Oliver AJ. Varying treatment strategies for reconstruction of maxillary atrophy with implants. Results in 98 patients. *J Oral Maxillofac Surg* 1994; 52: 210-216.
- Jensen OT. Site classification for the osseointegrated implant. *J Prosthet Dent* 1989; 61: 228-234.

Jensen OT, Schulman LB, Block MS, Iacono VJ. Report of the Sinus Consensus Conference of 1996. *Int J Oral Maxillofac Impl* 1998; 13(suppl): 11-32.

Jensen OT. The sinus bone graft. Quintessence Publishing Co, Inc; ISBN 0-86715-343-1, 1999: 31-47.

Johansson C, Albrektsson T. Integration of screw implants in the rabbit: A 1-year follow-up of removal torque of titanium implants. *Int J Oral Maxillofac Impl* 1987; 2: 69-75.

Johansson P, Strid K-G. Assessment of bone quality from cutting resistance during implant surgery. *Int J Oral Maxillofac Impl* 1994; 9: 279-288.

Jonsson R. Metoder för benmineralbestämning in vivo. Rapport för statens beredning för utvärdering av medicinsk metodik (SBU). Rapport KFANÅL 1994; 2: 1-31.

Kahnberg K-E, Nyström E, Bartholdsson L. Combined use of bone grafts and Brånemark fixtures in the treatment of severely resorbed maxillae. *Int J Oral Maxillofac Impl* 1989; 4: 297-304. Desjardins RP, Tolman DE. Prosthetic-surgical reconstruction of the severely resorbed maxilla with iliac bone grafting and tissue-integrated prostheses. *Int J Oral Maxillofac Impl* 1987; 2: 155-166.

Klemetti E, Kolmakov S, Heiskanen P, Vainio P, Lassila V. Panoramic mandibular index and bone mineral densities in postmenopausal women. *Oral Surg Oral Med Oral Pathol* 1993a; 75(6): 774-779.

Klemetti E, Vainio P, Lassila V, Alhava E. Trabecular bone mineral density of mandible and alveolar height in postmenopausal women. *Scand J Dent Res* 1993b; 101(3): 166-170.

Klemetti E, Vainio P, Lassila V, Alhava E. Cortical bone mineral density in the mandible and osteoporosis status in postmenopausal women. *Scand J Dent Res* 1993c; 101(4): 219-223.

Klemetti E, Vainio P, Lassila V. Mineral density in the mandibles of partially and totally edentate postmenopausal women. *Scand J Dent Res* 1994a; 102(1): 64-67.

Klemetti E, Vainio P, Kroger H. Muscle strength and mineral densities in the mandible. *Gerodont* 1994b; 11(2): 76-79.

Klemetti E, Kolmakov S, Kroger H. Pantomography in assessment of the osteoporosis risk group. *Scand J Dent Res* 1994c; 102(1): 68-72.

Klemetti E, Kolmakov S. Morphology of the mandibular cortex on panoramic radiographs as an indicator of bone quality. *Dentamaxillofac Radiol* 1997; 26(1): 22-25.

Klinge B, Johansson CB, Albrektsson T, Hallström H, Engdahl T. A new method to obtain bone biopsies at implant sites peri-operatively: technique and bone structure. *Clin Oral Impl Res* 1995; 6: 91-95.

Krekmanov L. A modified method of simultaneous bone grafting and placement of endosseous implants in the severely atrophic maxilla. *Int J Oral Maxillofac Impl* 1995; 10: 682-688.

Kribbs PJ, Chesnut CH, Ott SM, Kilcoyne RF. Relationship between mandibular and skeletal bone in a population of normal women. *J Prosthet Dent* 1990; 63(1): 86-89.

Langer B, Langer L, Herrmann I, Jörneus L. The wide fixture: A solution for special bone situations and a rescue for the compromised implant. Part 1. *Int J Oral Maxillofac Impl* 1993; 8: 400-408.

Law AN, Bollen AM, Chen SK. Detecting osteoporosis using dental radiographs: a comparison of four methods. *J Am Dent Assoc* 1996; 127(12): 1734-1742.

Ledgerton D, Horner K, Devlin H, Worthington H. Panoramic mandibular index as a radiomorphometric tool: an assessment of precision. *Dentomaxillofac Radiol* 1997; 26: 95-100.

Lekholm U, Adell R, Brånemark P-I. Complications. In: Brånemark P-I, Zarb GA, Albrektsson T, eds.: *Tissue-Integrated Prostheses: Osseointegration in Clinical Dentistry*, Chicago, Quintessence Publ Co, 1985a: 233-240.

Lekholm U, Zarb GA. Patient selection and preparation. In: Brånemark P-I, Zarb GA, Albrektsson T, eds.: *Tissue-Integrated Prostheses: Osseointegration in Clinical Dentistry*, Chicago, Quintessence Publ Co, 1985b: 199-209.

Lekholm U. The Brånemark implant technique: A standardized procedure under continuous development. In: Laney WR, Tolman DE, eds.: *Tissue Integration in Oral, Orthopedic & Maxillofacial Reconstruction*, Mayo Medical Center, Rochester, Minnesota, Quintessence Books, 1990: 194-199.

Lekholm U, van Steenberghe D, Herrmann I, Bolender C, Folmer T, Gunne J, Henry P, Higuchi K, Laney WR, Lindén U. Osseointegrated implants in the treatment of partially edentulous jaws: A prospective 5-year multicenter study. *Int J Oral Maxillofac Impl* 1994; 9: 627-635.

Lekholm U. The surgical site. In: Lindhe J, Karring T, Lang NP, eds.: *Clinical Periodontology and Implant Dentistry*. 3rd ed. Copenhagen: Munksgaard 1997: 890-905.

Lekholm U, Gunne J, Henry P, Higuchi K, Linden U, Bergström C, van Steenberghe D. Survival of the Brånemark implant in the partially edentulous jaw. A 10 year prospective multicenter study. *Int J Oral Maxillofac Impl* 1999a; in press.

Lekholm U, Wannfors K, Isaksson S, Adielsson B. Oral implants in combination with bone grafts. A 3-year retrospective multicenter study using the Brånemark implant system. *Int J Oral Maxillofac Surg* 1999b; 28: 181-187.

Lindh C, Nilsson M, Klinge B, Petersson A. Quantitative computed tomography of trabecular bone in the mandible. *Dentomaxillofac Radiol* 1996a; 25: 146-150.

Lindh C, Petersson A, Rohlin M. Assessment of the trabecular pattern before endosseous implant treatment: diagnostic outcome of periapical radiography in the mandible. *Oral Surg Oral Med Oral Pathol Oral Radiol Endod* 1996b; 82: 335-343.

Lindh C, Petersson A, Klinge B, Nilsson M. Trabecular bone volume and bone mineral density in the mandible. *Dentomaxillofac Radiol* 1997; 26: 101-106.

Lind M. Growth factor stimulation of bone healing. Effects on osteoblasts, osteotomies, and implant fixation. Thesis. Faculty of Health Sciences, University of Aarhus, Denmark. *Acta Orthop Scand* 1998; 69: Suppl 283.

Listgarten MA. Soft and hard tissue response to endosseous dental implants. *Anat Rec* 1996; 245(2): 410-425.

Lockington TJ, Bennett GC. Osteoporosis and the jaws: questions remain to be answered. *Gerodont* 1994; 11(2): 67-75.

Lundgren AK. On factors influencing guided regeneration and augmentation of intramembraneous bone. Thesis. Department of Biomaterials/Handicap Research, Göteborg University, Göteborg, Sweden. 1999.

Lundgren D, Lundgren AK, Sennerby L. The effect of mechanical intervention on jaw bone density. An experimental study in the rabbit. *Clin Oral Impl Res* 1995; 6: 54-59.

Lundgren S, Rasmusson L, Sjöström M, Sennerby L. Simultaneous or delayed placement of titanium implants in free autogenous iliac bone grafts. Histological analysis of the bone graft-titanium interface in 10 consecutive patients. *Int J Oral Maxillofac Surg* 1999; 28: 31-37.

Lynch SE, Buser D, Hernandez RA, Weber HP, Stich H, Fox CH, Williams RC. Effects of the platelet-derived growth factor/insulin-like growth factor-1 combination on bone regeneration around titanium dental implants. Results of a pilot study in beagle dogs. *J Periodontol* 1991; 62: 710-716.

Läkemedelsverket 1:97. Behandling av osteoporos - Rekommendationer. Särtryck ur Information från Läkemedelsverket 1:97.

Majumdar S, Weinstein RS, Prasad RR. Application of fractal geometry techniques to the study of trabecular bone. *Med Phys* 1993; 20(6): 1611-1619.

Marcus R. Endogenous and nutritional factors affecting bone. *Bone* 1996; 18(1), Suppl: 11S-13S.

Martin RB. Determinants of the mechanical properties of bone. *J Biomechanics* 1991; 24: 79-88.

Marx RE, Carlson ER, Eichstaedt RM, Schimmele SR, Strauss JE, Georgeff KR. Platelet-rich plasma: Growth factor enhancement for bone grafts. *Oral Surg Oral Med Oral Pathol Oral Radiol Endod* 1998; 85(6): 638-646.

Matteson SR, Deahl ST, Alder ME, Nummikoski PV. Advanced imaging methods. *Crit Rev Oral Biol Med* 1996; 7(4): 346-395.

McClung M, Clemmesen B, Daifotis A, Gilchrist NL, Eisman J, Weinstein RS, Fuleihan G el-H, Reda C, Yates AJ, Ravn P. Alendronate prevents postmenopausal bone loss in women without osteoporosis. A double-blind, randomized, controlled trial. Alendronate Osteoporosis Prevention Study Group. *Ann Intern Med* 1998; 128(4): 253-261.

Mellonig JT, Bowers GM, Bright RW, Lawrence JJ. Clinical evaluation of freeze-dried bone allografts in periodontal osseous defects. *J Periodontol* 1976; 47: 125-132.

Melton LJ. Epidemiology of osteoporosis: Predicting who is at risk. *Annals New York Acad Sci* 1990; 295-306.

Meredith N, Alleyne D, Cawley P. Quantitative determination of the stability of the implant-tissue interface using resonance frequency analysis. *Clin Oral Impl Res* 1996a; 7: 261-267.

Meredith N, Rasmusson L, Sennerby L, Alleyne D. Mapping implant stability by resonance frequency analysis. *Med Sci Res* 1996b; 24: 191-193.

Meredith N, Shagaldi F, Alleyne D, Sennerby L, Cawley P. The application of resonance frequency measurements to study the stability of titanium implants during healing in rabbit tibia. *Clin Oral Impl Res* 1997a; 8: 234-243.

Meredith N, Book K, Friberg B, Jemt T, Sennerby L. Resonance frequency measurements of implant stability in-vivo. A cross-sectional and longitudinal study of resonance frequency measurements on implants in the edentulous and partially dentate maxilla. *Clin Oral Impl Res* 1997b; 8: 226-233.

Meredith N, Friberg B, Sennerby L, Aparicio C. Relationship between contact time measurements and PTV values when using the Periotest to measure implant stability. *Int J Prosthodont* 1998; 11: 269-275.

Mericske-Stern R, Milani D, Mericske E, Olah A. Periotest measurements and osseointegration of mandibular ITI implants supporting overdentures. A one-year longitudinal study. *Clin Oral Impl Res* 1995; 6: 73-82.

Misch CE. Density of bone: Effect on treatment plans, surgical approach, healing and progressive bone loading. *Int J Oral Impl* 1990; 6: 23-31.

Mori H, Manabe M, Kurachi Y, Nagumo M. Osseointegration of dental implants in rabbit bone with low mineral density. *J Oral Maxillofac Surg* 1997; 55: 351-361.

Nevins M, Mellonig JT. Enhancement of the damaged edentulous ridge to receive dental implants: A combination of allograft and Gore-Tex membrane. *Int J Periodont Rest Dent* 1992; 12: 97-111.

Nevins M, Langer B. The successful application of osseointegrated implants to the posterior jaw: A long-term retrospective study. *Int J Oral Maxillofac Impl* 1993; 8: 428-432.

Nyström E, Kahnberg K-E, Gunne J. Bone grafts and Brånemark implants in the treatment of the severely resorbed maxilla: A 2-year longitudinal study. *Int J Oral Maxillofac Impl* 1993; 8: 45-53.

Oda T, Sawaki Y, Ueda M. Alveolar ridge augmentation by distraction osteogenesis using titanium implants: an experimental study. *Int J Oral Maxillofac Surg* 1999; 28: 151-156.

Olivé J, Aparicio C. The Periotest method as a measure of osseointegrated oral implant stability. *Int J Oral Maxillofac Impl* 1990; 5: 390-400.

Olsson M, Friberg B, Nilsson H, Kultje C. Mk II-A modified self-tapping Brånemark implant: 3-year results of a controlled prospective pilot study. *Int J Oral Maxillofac Impl* 1995; 10: 15-21.

Orenstein IH, Tarnow DP, Morris HF, Ochi S. Factors affecting implant mobility at placement and integration of mobile implants at uncovering. *J Periodontol* 1998; 69(12): 1404-1412.

Palou ME, McQuade MJ, Rossmann JA. The use of ultrasound for the determination of periodontal bone morphology. *J Periodontol* 1987; 58(4): 262-265.

Palmer RM, Smith BJ, Palmer PJ, Floyd PD. A prospective study of Astra single-tooth implant. *Clin Oral Impl Res* 1997; 8: 173-179.

Pinholt EM, Haanaes HR, Roervik M, Donath K, Bang G. Alveolar ridge augmentation by osteoinductive materials in goats. *Scand J Dent Res* 1992; 100: 361-365.

Pinholt EM, Haanaes HR, Donath K, Bang G. Titanium implant insertion into dog alveolar ridges augmented by allogenic material. *Clin Oral Impl Res* 1994; 5: 213-219.

Quintero G, Mellonig JT, Gambill V. A six-month clinical evaluation of decalcified freeze-dried bone allograft in human periodontal defects. *J Periodontol* 1982; 53: 726-730.

Quirynen M, Lamoral Y, Dekeyser C, Peene P, van Steenberghe D, Bonte J, Baert A. The CT scan standard reconstruction technique for reliable jaw bone volume determination. *Int J Oral Maxillofac Impl* 1990; 5: 384-389.

Quirynen M, Naert I, van Steenberghe D. Fixture design and overload influence marginal bone loss and fixture success in the Brånemark® system. *Clin Oral Impl Res* 1992; 3: 104-111.

- Randow K, Ericsson I, Nilner K, Petersson A, Glantz P-O. Immediate functional loading of Brånemark dental implants. An 18-month clinical follow-up study. *Clin Oral Impl Res* 1999; 10: 8-15.
- Rangert BR, Sullivan RM, Jemt TM. Load factor control for implants in the posterior partially edentulous segment. *Int J Oral Maxillofac Impl* 1997; 12: 360-370.
- Rasmusson L, Meredith N, Sennerby L. Measurements of stability changes of titanium implants with exposed threads subjected to barrier membrane induced bone augmentation. An experimental study in the rabbit tibia. *Clin Oral Impl Res* 1997; 8: 316-322.
- Rasmusson L. On implant integration in membrane-induced and grafted bone. Thesis. Department of Biomaterials/Handicap Research and Department of Oral & Maxillofacial Surgery, Göteborg University, Göteborg, Sweden. 1998a.
- Rasmusson L, Meredith N, Kahnberg K-E, Sennerby L. Stability assessments and histology of titanium implants placed simultaneously with autogenous onlay bone in the rabbit tibia. *Int J Oral Maxillofac Surg* 1998b; 27: 229-235.
- Rasmusson L, Meredith N, Kahnberg K-E, Sennerby L. Effects of barrier membranes on bone resorption and implant stability in onlay bone grafts. An experimental study. *Clin Oral Impl Res* 1999a; 10: 267-277.
- Rasmusson L, Meredith N, Cho IH, Sennerby L. The influence of simultaneous versus delayed placement on the stability of titanium implants in onlay bone grafts. A histologic and biomechanic study in the rabbit. *Int J Oral Maxillofac Surg* 1999b; 28: 224-231.
- Razavi R, Zena RB, Khan Z, Gould AR. Anatomic site evaluation of edentulous maxillae for dental implant placement. *J Prosthodont* 1995; 4(2): 90-94.
- Reilly DT, Burstein AH. Review article. The mechanical properties of cortical bone. *J Bone Joint Surg* 1974; 56A: 1001-1022.
- Renouard F, Arnoux J-P, Sarment DP. Five-mm-diameter implants without a smooth collar: Report on 98 consecutive placements. *Int J Oral Maxillofac Impl* 1999; 14: 101-107.
- Roberts WE, Smith RK, Zilberman Y, Mozsary PG, Smith RS. Osseous adaptation to continuous loading of rigid endosseous implants. *Am J Orthod* 1984; 86(2): 95-111.
- Rutherford RB, Sampath TK, Reuger DC, Taylor TD. Use of bovine osteogenic protein to promote rapid osseointegration of endosseous dental implants. *Int J Maxillofac Impl* 1992; 7: 297-301.
- Sailer HF, Kolb E. Application of purified bone morphogenetic protein (BMP) in cranio-maxillo-facial surgery. BMP in compromised surgical reconstructions using titanium implants. *J Craniomaxillofac Surg* 1994; 22(1): 2-11.

Schnitman PA, Wöhrle PS, Rubenstein JE. Immediate fixed interim prostheses supported by two-stage threaded implants: Methodology and results. *J Oral Impl* 1990; XVI: 96-105.

Schnitman P, Wöhrle P, Rubenstein J, DaSilva J, Wang N-H. Ten-year results for Brånemark implants immediately loaded with fixed prostheses at implant placement. *Int J Oral Maxillofac Impl* 1997; 12: 495-503.

Schulte W, Lucas D, Mühlbradt L, Scholz F, Bretsch J, Frei D, Gudat II, Knig M, Markl M, Quante F, Schief D, Topkaya A. Periotest - ein neues Verfahren und Gerät zur Messung der Function des Parodontiums. *Zahnärztl Mitt* 1983; 73: 1229.

Schwartz Z, Somers A, Mellonig JT, Carnes DL, Wozney JM, Dean DD, Cochran DL, Boyan BD. Addition of human recombinant bone morphogenetic protein-2 to inactive commercial human demineralized freeze-dried bone allograft makes an effective composite bone inductive implant material. *J Periodontol* 1998; 69: 1337-1345.

Sennerby L, Carlsson GE, Bergman B, Warfvinge J. Mandibular bone resorption in patients treated with tissue-integrated prostheses and in complete-denture wearers. *Acta Odontol Scand* 1988; 46: 135-140.

Sennerby L. On the bone tissue response to titanium implants. Thesis. Department of Handicap Research, Göteborg University, Göteborg, Sweden. 1991.

Sennerby L, Thomsen P, Ericsson L. A morphometric and biomechanic comparison of titanium implants inserted in rabbit cortical and cancellous bone. *Int J Oral Maxillofac Impl* 1992; 7: 62-71.

Sennerby L, Roos J. Surgical determinants of clinical success of osseointegrated oral implants: A review of the literature. *Int J Prosthodont* 1998; 11: 408-420.

Sennerby L, Meredith N. Resonance frequency analysis: Measuring implant stability and osseointegration. *Compendium* 1998; 19: 493-502

Sennerby L, Meredith N. Diagnostic de la stabilite d'un implant par l'analyse de sa frequence de resonance. *Implant* 1999; 5: 1-8.

Smith RA. The effect on TGF- β 1 on osseointegration. *CDA J* 1995; 23: 49-53.

Starck WJ, Epker BN. Failure of osseointegrated dental implants after diphosphonate therapy for osteoporosis. A case report. *Int J Oral Maxillofac Impl* 1995; 10: 74-78.

Strid K-G. Radiographic results. In: Brånemark P-I, Zarb GA, Albrektsson T, eds.: *Tissue-Integrated Prostheses: Osseointegration in Clinical Dentistry*, Chicago, Quintessence Publ Co, 1985: 187-198.

Stulberg BN, Bauer TW, Watson JT, Richmond B. Bone quality. Roentgenographic versus histologic assessment of hip bone structure. *Clin Orthop Rel Res* 1989; 240: 200-205.

Sturtridge W, Lentle B, Hanley DA. Prevention and management of osteoporosis: consensus statements from the Scientific Advisory Board of the Osteoporosis Society of Canada. 2. The use of bone density measurements in the diagnosis and management of osteoporosis. *CMAJ* 1996; 155(7): 924-929.

Sugaya K. Study on method for examining bone quality for dental implant. Relationship between cutting force and bone mineral content. *Shikwa Gakuho* 1990; 90: 607-633 (Engl abstr).

Sullivan DY, Sherwood RL, Mai TN. Preliminary results of a multicenter study evaluating a chemically enhanced surface for machined commercially pure titanium implants. *J Prosthet Dent* 1997; 78: 379-386.

Sundén S, Gröndal K, Gröndal H-G. Accuracy and precision in the radiographic diagnosis of clinical instability in Brånemark dental implants. *Clin Oral Impl Res* 1995; 6: 220-226.

Taguchi A, Tanimoto K, Ogawa M, Sunayashiki T, Wada T. Effect of size of region of interest on precision of bone mineral measurements of the mandible by quantitative computed tomography. *Dentomaxillofac Radiol* 1991; 20(1): 25-29.

Taguchi A, Tanimoto K, Sueti Y, Otani K, Wada T. Oral signs as indicators of possible osteoporosis in elderly women. *Oral Surg Oral Med Oral Pathol Oral Radiol Endod* 1995; 80(5): 612-616.

Taguchi A, Sueti Y, Ohtsuka M, Otani K, Tanimoto K, Ohtaki M. Usefulness of panoramic radiography in the diagnosis of postmenopausal osteoporosis in women. Width and morphology of inferior cortex of the mandible. *Dentomaxillofac Radiol* 1996; 25(5): 263-267.

Tallgren A. The continuing reduction of the residual alveolar ridges in complete denture wearers: A mixed-longitudinal study covering 25 years. *J Prosthet Dent* 1972; 27: 120-132.

Tammisalo E, Hallikainen D, Kanerva H, Tammisalo T. Comprehensive oral X-ray diagnosis: Scanora® multimodal radiography. A preliminary description. *Dentomaxillofac Radiol* 1992; 21: 9-15.

Tarnow DP, Emtiaz S, Classi A. Immediate loading of threaded implants at stage 1 surgery in edentulous arches: Ten consecutive case reports with 1- to 5-year data. *Int J Oral Maxillofac Impl* 1997; 12: 319-324.

Teerlinck J, Quirynen M, Darius P, van Steenberghe D. Periotest®: An objective clinical diagnosis of bone apposition toward implants. *Int J Oral Maxillofac Impl* 1991; 6: 55-61.

Tolman DE. Reconstructive procedures with endosseous implants in grafted bone. A review of the literature. *Int J Oral Maxillofac Impl* 1995; 10: 275-294.

Traxler M, Ulm C, Solar P, Lill W. Sonographic measurement versus mapping for determination of residual ridge width. *J Prosthet Dent* 1992; 67: 358-361.

Tricio J, van Steenberghe D, Rosenberg D, Duchateau L. Implant stability related to insertion torque force and bone density: An in vitro study. *J Prosthet Dent* 1995; 74: 608-612.

Triplett RG, Mason ME, Alfonso WF, McAnear JT. Endosseous cylinder implants in severely atrophic mandibles. *Int J Oral Maxillofac Impl* 1991; 6: 264-269.

Triplett RG, Schow SR. Autologous bone grafts and endosseous implants: Complementary techniques. *J Oral Maxillofac Surg* 1996; 54: 486-494.

Trisi PR, Rao W. Bone classification: clinical-histomorphometric comparison. *Clin Oral Impl Res* 1999; 10: 1-7.

Truhlar RS, Morris HF, Ochi S, Winkler S. Assessment of implant mobility at second-stage surgery with the Periotest: DICRG interim report no.3. Dental Implant Clinical Research Group. *Impl Dent* 1994; 3(3): 153-156.

Truhlar RS, Farish SE, Scheitler LE, Morris HF, Ochi S. Bone quality and implant design-related outcomes through stage II surgical uncovering of Spectra-System root form implants. *J Oral Maxillofac Surg* 1997; 55: 46-54.

Ulm CW, Solar P, Blahout R, Matejka M, Gruber H. Reduction of the compact and cancellous bone substances of the edentulous mandible caused by resorption. *Oral Surg Oral Med Oral Pathol* 1992; 74(2): 131-136.

Ulm CW, Kneissel M, Hahn M, Solar P, Matejka M, Donath K. Characteristics of the cancellous bone of edentulous mandibles. *Clin Oral Impl Res* 1997; 8(2): 125-130.

Urbani G, Lombardo G, Santi E, Consolo U. Distraction osteogenesis to achieve mandibular vertical bone regeneration: A case report. *Int J Periodont Rest Dent* 1999; 19: 321-331.

Urist M. Bone formation by autoinduction. *Science* 1965; 150: 893-899.

Van Oosterwyck H, Duyck J, Vander Sloten J, Van der Perre G, De Cooman M, Lievens S, Puers R, Naert I. The influence of bone mechanical properties and implant fixation upon bone loading around oral implants. *Clin Oral Impl Res* 1998; 9: 407-418.

van Steenberghe D, Quirynen M, Calberson L, Demanet M. A prospective evaluation of the fate of 697 consecutive intra-oral fixtures ad modum Brånemark in the rehabilitation of edentulism. *J Head & Neck Pathol* 1987; 6: 53-58.

van Steenberghe D, Lekholm U, Bolender C, Folmer T, Henry P, Herrmann I, Higuchi K, Laney W, Linden U, Åstrand P. The applicability of osseointegrated oral implants in the

- rehabilitation of partial edentulism: A prospective multicenter study on 558 fixtures. *Int J Oral Maxillofac Impl* 1990; 5: 272-281.
- van Steenberghe D. Oral implants. *Curr Opin Dent* 1991; 1: 138-145.
- Venturelli A. A modified surgical protocol for placing implants in the maxillary tuberosity: Clinical results at 36 months after loading with fixed partial dentures. *Int J Oral Maxillofac Impl* 1996; 11: 743-749.
- von Wowern N. Variations in the structure within the trabecular bone of the mandible. *Scand J Dent Res* 1977a; 85: 613-622.
- von Wowern N. Variations in bone mass within the cortices of the mandible. *Scand J Dent Res* 1977b; 85: 444-455.
- von Wowern N, Stoltze K. Sex and age differences in bone morphology of mandibles. *Scand J Dent Res* 1978; 86: 478-485.
- von Wowern N, Lyager Storm T, Olgaard K. Bone mineral content by photon absorptiometry of the mandible compared with that of the forearm and the lumbar spine. *Calcif Tissue Int* 1988; 42: 157-161.
- von Wowern N, Harder F, Hjorting-Hansen E, Gotfredsen K. ITI implants with overdentures: a prevention of bone loss in edentulous mandibles? *Int J Oral Maxillofac Impl* 1990; 5(2): 135-139.
- Wallach S, Feinblatt JD, Avioli LV. Editorial. The bone "quality" problem. *Calcif Tissue Int* 1992; 51: 169-172.
- Watson EL, Katz RV, Adelezzi R, Gift HC, Dunn SM. The measurement of mandibular cortical bone height in osteoporotic vs. non-osteoporotic postmenopausal women. *Spec Care Dentist* 1995; 15(3): 124-128.
- Weyant RJ, Burt BA. An assessment of survival rates and within-patient clustering of failures for endosseous oral implants. *J Dent Res* 1993; 72: 2-8.
- Wilding RJ, Slabbert JC, Kathree H, Owen CP, Crombie K, Delport P. The use of fractal analysis to reveal remodelling in human alveolar bone following the placement of dental implants. *Arch Oral Biol* 1995; 40(1): 61-72.
- Williamson RA. Rehabilitation of the resorbed maxilla and mandible using autogenous bone grafts and osseointegrated implants. *Int J Oral Maxillofac Impl* 1996; 11: 476-488.
- Worthington P, Bolender CL, Taylor TD. The Swedish system of osseointegrated implants: problems and complications encountered during a 4-year trial period. *Int J Oral Maxillofac Impl* 1987; 2: 77-84.

Wyatt C, Zarb GA. Treatment outcomes of patients with implant-supported fixed prostheses. *Int J Oral Maxillofac Impl* 1998; 13: 204-211.

Yan J, Xiang W, Baolin L, White FH. Early histologic response to titanium implants complexed with bovine bone morphogenetic protein. *J Prosthet Dent* 1994; 71(3): 289-294.

Zabalegui J, Gil JA, Zabalegui B. Magnetic resonance imaging as an adjunctive diagnostic aid in patient selection for endosseous implants: Preliminary study. *Int J Oral Maxillofac Impl* 1990; 5: 283-288.

Zarb GA, Jansson T. Prosthodontic procedures. In: Brånemark P-I, Zarb GA, Albrektsson T, eds.: *Tissue-Integrated Prostheses: Osseointegration in Clinical Dentistry*, Chicago, Quintessence Publ Co, 1985: 241-282.

Zarb GA, Schmitt A. The longitudinal clinical effectiveness of osseointegrated dental implants: The Toronto study. Part III: Problems and complications encountered. *J Prosthet Dent* 1990; 64: 185-194.

Zarb GA, Albrektsson T. Osseointegration: A requiem for the periodontal ligament? *Int J Periodont Rest Dent* 1991;11: 88-91.

Åstrand P, Almfeldt I, Brunell G, Hamp S-E, Hellem S, Karlsson U. Non-submerged implants in the treatment of the edentulous lower jaw. A 2-year longitudinal study. *Clin Oral Impl Res* 1996a; 7: 337-344.

Åstrand P, Nord P-G, Brånemark P-I. Titanium implants and onlay bone graft to the atrophic edentulous maxilla. *Int J Oral Maxillofac Surg* 1996b; 25: 25-29.

Åstrand P, Engquist B, Dahlgren S, Engquist E, Feldmann H, Gröndahl K. Astra Tech and Brånemark System implants: A prospective 5-year comparative study. Results after one year. *Clin Impl Dent Rel Res* 1999; 1: 17-26.

På grund av upphovsrättsliga skäl kan vissa ingående delarbeten ej publiceras här.
För en fullständig lista av ingående delarbeten, se avhandlingens början.

Due to copyright law limitations, certain papers may not be published here.
For a complete list of papers, see the beginning of the dissertation.



GÖTEBORGS UNIVERSITET

[Illegible text block]

[Illegible section header]

- [Illegible list of items]

[Illegible text block]

[Illegible text block]

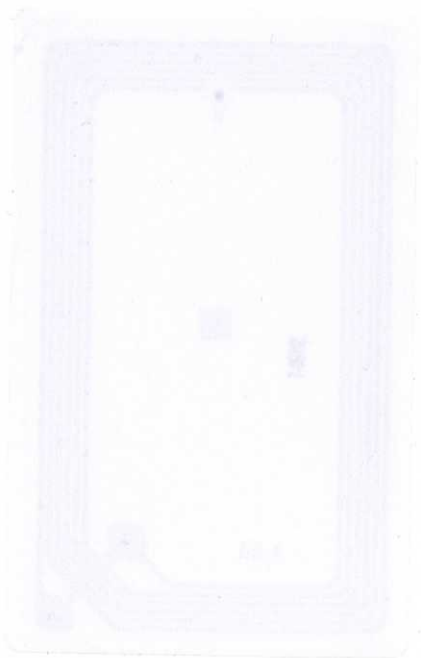

Cover design by Dr. Johan Roos.