



School of Business,
Economics and Law
GÖTEBORG UNIVERSITY



SIR-C Swedish Intermodal Transport
Research Centre

The Heuristics Intermodal Transport Model Calculation System

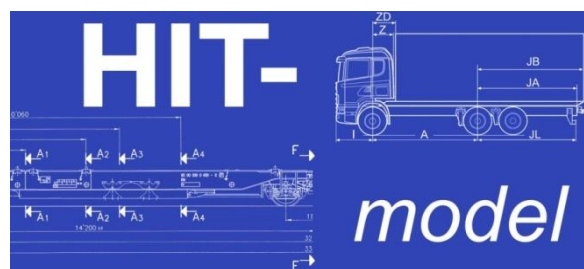

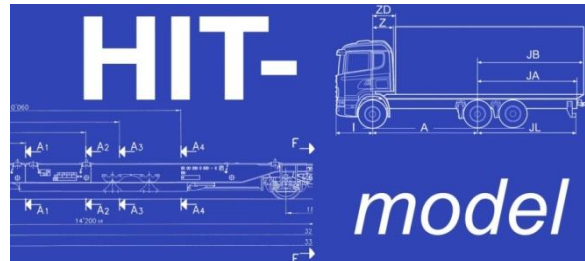

March 2011

This report is a part of the project “Strategic modelling of combined transport between road and rail in Sweden” funded by the Swedish Road Administration, Vägverket, and the Swedish Rail Administration, Banverket, through the Swedish Intermodal Transport Research Centre, Sir-C.

Jonas Flodén
Department of Business Administration
School of Business, Economics and Law
University of Gothenburg
P.O. Box 610
SE 405 30 Göteborg
Sweden

E-mail: jonas.floden@handels.gu.se
URL: <http://www.handels.gu.se/fek/logistikgruppen>
Telephone: +46-(0)31-786 51 31

The Heuristics Intermodal Transport Model Calculation System

Intermodal transport is by many considered to be a possible solution to increased transport needs of the future and also to be a way of reducing the negative impacts of transport such as emission, land use, and congestion. In Swedish as well as in European transport policy, goals have been expressed about increasing the market shares of intermodal transport.

However, increasing the market share of intermodal transport calls for increased knowledge about which strategies are optimal/satisfying for the continued development of the intermodal transport system. This knowledge is required at different levels such as the transport policy level, the operators' level, and the shippers' level. There is a need for answers to questions about which market shares are possible in total, for regions, and for transport links; what an optimal system design looks like in terms of transport links, train frequencies, and train sizes; where intermodal terminals and road connections should be located; what rolling stock should be used; and how pick-up and distribution areas around terminals should be drawn. These answers are needed in terms of realistic, strategic scenarios that point to viable roads for the development of intermodal transport. The scenarios provide information that is necessary for the design of effective transport policy, for operators' investments and system designs, for the formulation of business missions and strategies by operators, and for the choice of transport solutions for shippers. Model tools designed specifically for analysing intermodal transport in the way described above and producing the output described above do not exist in the market.

A computer based analysis and decision support model for Swedish domestic and border crossing intermodal transport has been developed at The School of Business, Economics and Law at University of Gothenburg. The Heuristics Intermodal Transport model HIT-Model, is a user friendly model that can be run on an ordinary desktop PC. The model takes its starting point in a competitive situation between traditional all-road transport and intermodal transport, where the theoretical potential of intermodal transport is determined by how well it performs in comparison with all-road transport. The computer based model is aimed at being capable of giving answers to the questions mentioned above under different conditions concerning total demand for transport, cost structures, relative price changes, transport vehicle capacity, and transport vehicle performance etc. The model considers the competitive situation between different modes of transport in the market.

This project aims at supplying the model with user interface and a sufficiently broad and relevant empirical data base making it possible to make the various types of analyses that were described above. To collect all the data that is needed for every single analysis is not efficient, since the same data to a large extent will be required for different types of use of the model, and since data collection is time consuming and expensive.

This report contains of four parts. The parts are designed to be read both as one report and individually as separate reports. Some overlap might therefore occur between the parts in order to make the separate reports also possible to read as stand-alone reports.



Table of contents

Part One User Guide

1	INTRODUCTION	5
1.1	MODEL HEURISTICS	5
1.2	MODEL BACKGROUND	6
1.3	TECHNICAL OVERVIEW	6
1.3.1	Model size allowed	7
1.3.2	Model run times	7
1.4	WHAT IS HEURISTICS?	7
1.5	DEFINITION OF TERMS AND CONCEPTS	8
1.5.1	All-road transport	8
1.5.2	Combined transport	8
1.5.3	Demand occurrence	8
1.5.4	Demand point	8
1.5.5	Intermodal transport	8
1.5.6	Intermodal terminal	8
1.5.7	ITU	8
1.5.8	Transport link	8
1.5.9	Train route	9
1.5.10	Train loop	9
1.5.11	Transshipment	9
1.5.12	Terminal	9
1.5.13	Terminal handling	9
2	USER INTERFACE IN MICROSOFT ACCESS	10
2.1	WHAT IS A DATABASE?	10
2.2	USER INTERFACE TECHNICAL INFORMATION	10
2.2.1	Field sizes	11
3	USING THE HIT-MODEL	12
3.1	WORKING WITH THE USER INTERFACE	12
3.2	USER INTERFACE STRUCTURE	17
3.3	HIT-MODEL CONTROL FUNCTIONS	17
3.4	GENERAL DATA	19
4	INPUT DATA	20
4.1	TRANSPORT NETWORK AND DEMAND	20
4.1.1	Geographical locations	20
4.1.2	Transport Demand	21
4.1.3	Road distances	22
4.1.4	Rail distances	23
4.1.5	Terminal Areas	23
4.2	COST AND ENVIRONMENT	23
4.2.1	Lorries	24
4.2.2	Train Types	26

4.2.3	Terminal Data	27
4.2.4	Common Fixed Costs	27
4.3	SETTINGS AND TRANSPORT FRAMEWORK	28
4.3.1	Time periods	28
4.3.2	Allowed Train Loops	33
4.3.3	Allowed Lorries	35
4.3.4	Control Parameters	36
5	OUTPUT DATA	38
5.1	SUMMARY DATA	38
5.1.1	User interface	38
5.2	INTERMODAL TRANSPORT DEMAND	38
5.2.1	User interface	40
5.3	ALL-ROAD TRANSPORT DEMAND	40
5.3.1	User interface	42
5.4	TRAIN SYSTEM DATA	42
5.4.1	User interface	42
6	ANALYSES AND THE HIT-MODEL AS A CALCULATION MODEL	43
6.1	ANALYSES	43
6.2	THE HIT-MODEL AS A CALCULATION MODEL	43
6.2.1	Mixing calculations and heuristics	43
6.2.2	GIS visualisation tool	44
7	FILE FORMATS	45
7.1	INPUT DATA	45
7.2	TRANSPORT NETWORK AND DEMAND	45
7.2.1	Transport Demand	45
7.2.2	Road Distances	45
7.2.3	Rail Distance	46
7.2.4	Terminal Areas	46
7.3	COST AND ENVIRONMENT	47
7.3.1	All-Road Lorry Types	47
7.3.2	Intermodal Transport Lorry Types	47
7.3.3	Train Types	48
7.3.4	Terminal Handling Data	49
7.3.5	Common Fixed Costs	50
7.4	SETTINGS AND TRANSPORT FRAMEWORK	50
7.4.1	Time periods	50
7.4.2	Allowed Train Loops	51
7.4.3	Allowed Lorries	52
7.4.4	Control Parameters	53
7.5	OUTPUT DATA	53
7.5.1	Summary data	53
7.5.2	Intermodal Transport Demand	55
7.5.3	Road Transport Demand	56
7.5.4	Train System Data	58
8	LIST OF VARIABLES AND CONSTRAINTS	60

Part Two Suggested Input Data

1.	Introduction	4
2.	Road costs	5
2.1.	Operating costs	5
2.2.	Environment	6
3.	Rail costs	7
3.1.	Rail capacity	7
3.2.	Engine costs	8
3.3.	Empty wagon costs	8
3.4.	Using wagon costs	9
3.5.	Environment	9
3.6.	Social economic costs	11
4.	Terminal costs	13
4.1.	Social economic costs	13
5.	Demand for transport	15
5.1.	The commodity flow survey	15
5.2.	The transport operators	15
5.3.	Combining sources	16
6.	References	18

Part Three GIS visualisation tool

1. Introduction	5
2. Principles of visualisation of flows in cartography	6
3. Installing the ETGeoWizard extension	11
System requirements	
Installation process	
Loading ETGeoWizards extention into ArcGIS	
4. How to generate lines between nodes	13
Introduction	
Preparing inputs	
Generate lines from the input data	
5. How to Visualize flows and create maps	18
Modify lines	
Create a map layout for printing	
6. Future developments	22
References	23
Appendix	24

Part Four Heuristics

1	HEURISTICS MANUAL	4
1.1	MODEL BACKGROUND	4
1.2	MODEL CONCEPT AND PROBLEMS THE MODEL CAN SOLVE	4
1.3	WHAT IS HEURISTICS?	5
1.4	BASIC HEURISTICS	5
1.5	DEFINITION OF TERMS AND CONCEPTS	6
1.5.1	All-road transport	6
1.5.2	Combined transport	6
1.5.3	Demand point	6
1.5.4	Demand occurrence	6
1.5.5	Intermodal transport	6
1.5.6	Intermodal terminal	7
1.5.7	ITU	7
1.5.8	Transport link	7
1.5.9	Train route	7
1.5.10	Train loop	7
1.5.11	Transshipment	8
1.5.12	Terminal	8
1.5.13	Terminal handling	8
2	HEURISTICS	9
2.1	JENSEN PRINCIPLES	9
2.2	THE HIT-MODEL	10
2.3	FRAMEWORK CALCULATIONS	10
2.4	MODAL CHOICE	12
2.4.1	Lowest Cost System	13
2.4.2	Maximum Weight Transfer	17
2.5	END CALCULATIONS AND OUTPUT	19
2.6	A CALCULATED EXAMPLE	19
3	TIME	23
3.1	DELIVERY TIME WINDOWS	24
3.2	TIME WINDOW OVERLAP	24
3.3	COMPARATIVE DELIVERY TIME GAPS	25
3.4	DEPARTURE TIME WINDOWS	26
3.5	COMPARATIVE DEPARTURE TIME GAPS	26
3.6	OPERATING WINDOW	27
4	SIMPLIFIED FLOW CHART	29
5	DETAILED FLOW CHART	32
6	REFERENCES	37

MANUAL

User Guide

The Heuristics Intermodal Transport Model

HIT-Model

v. 1.0

Jonas Flodén

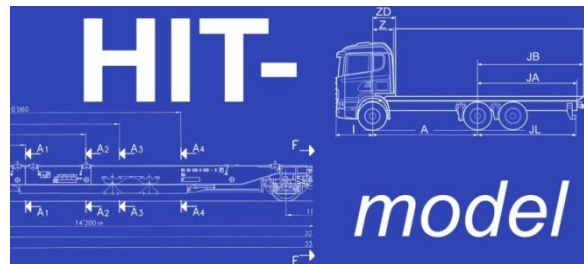

Jonas Flodén
Department of Business Administration
School of Business, Economics and Law
University of Gothenburg
P.O. Box 610
SE 405 30 Göteborg
Sweden

E-mail: jonas.floden@handels.gu.se
URL: <http://www.handels.gu.se/fek/logistikgruppen>
Telephone: +46-(0)31-786 51 31

Table of Contents

1	INTRODUCTION	5
1.1	MODEL HEURISTICS	5
1.2	MODEL BACKGROUND	6
1.3	TECHNICAL OVERVIEW	6
1.3.1	<i>Model size allowed</i>	7
1.3.2	<i>Model run times</i>	7
1.4	WHAT IS HEURISTICS?	7
1.5	DEFINITION OF TERMS AND CONCEPTS	8
1.5.1	<i>All-road transport</i>	8
1.5.2	<i>Combined transport</i>	8
1.5.3	<i>Demand occurrence</i>	8
1.5.4	<i>Demand point</i>	8
1.5.5	<i>Intermodal transport</i>	8
1.5.6	<i>Intermodal terminal</i>	8
1.5.7	<i>ITU</i>	8
1.5.8	<i>Transport link</i>	8
1.5.9	<i>Train route</i>	9
1.5.10	<i>Train loop</i>	9
1.5.11	<i>Transshipment</i>	9
1.5.12	<i>Terminal</i>	9
1.5.13	<i>Terminal handling</i>	9
2	USER INTERFACE IN MICROSOFT ACCESS	10
2.1	WHAT IS A DATABASE?	10
2.2	USER INTERFACE TECHNICAL INFORMATION	10
2.2.1	<i>Field sizes</i>	11
3	USING THE HIT-MODEL	12
3.1	WORKING WITH THE USER INTERFACE	12
3.2	USER INTERFACE STRUCTURE	17
3.3	HIT-MODEL CONTROL FUNCTIONS	17
3.4	GENERAL DATA	19
4	INPUT DATA	20
4.1	TRANSPORT NETWORK AND DEMAND	20
4.1.1	<i>Geographical locations</i>	20
4.1.2	<i>Transport Demand</i>	21
4.1.3	<i>Road distances</i>	22
4.1.4	<i>Rail distances</i>	23
4.1.5	<i>Terminal Areas</i>	23
4.2	COST AND ENVIRONMENT	23
4.2.1	<i>Lorries</i>	24
4.2.2	<i>Train Types</i>	26
4.2.3	<i>Terminal Data</i>	27
4.2.4	<i>Common Fixed Costs</i>	27
4.3	SETTINGS AND TRANSPORT FRAMEWORK	28
4.3.1	<i>Time periods</i>	28
4.3.2	<i>Allowed Train Loops</i>	33

4.3.3	<i>Allowed Lorries</i>	35
4.3.4	<i>Control Parameters</i>	36
5	OUTPUT DATA	38
5.1	SUMMARY DATA.....	38
5.1.1	<i>User interface</i>	38
5.2	INTERMODAL TRANSPORT DEMAND	38
5.2.1	<i>User interface</i>	40
5.3	ALL-ROAD TRANSPORT DEMAND.....	40
5.3.1	<i>User interface</i>	42
5.4	TRAIN SYSTEM DATA.....	42
5.4.1	<i>User interface</i>	42
6	ANALYSES AND THE HIT-MODEL AS A CALCULATION MODEL	43
6.1	ANALYSES	43
6.2	THE HIT-MODEL AS A CALCULATION MODEL.....	43
6.2.1	<i>Mixing calculations and heuristics</i>	43
6.2.2	<i>GIS visualisation tool</i>	44
7	FILE FORMATS	45
7.1	INPUT DATA.....	45
7.2	TRANSPORT NETWORK AND DEMAND	45
7.2.1	<i>Transport Demand</i>	45
7.2.2	<i>Road Distances</i>	45
7.2.3	<i>Rail Distance</i>	46
7.2.4	<i>Terminal Areas</i>	46
7.3	COST AND ENVIRONMENT	47
7.3.1	<i>All-Road Lorry Types</i>	47
7.3.2	<i>Intermodal Transport Lorry Types</i>	47
7.3.3	<i>Train Types</i>	48
7.3.4	<i>Terminal Handling Data</i>	49
7.3.5	<i>Common Fixed Costs</i>	50
7.4	SETTINGS AND TRANSPORT FRAMEWORK	50
7.4.1	<i>Time periods</i>	50
7.4.2	<i>Allowed Train Loops</i>	51
7.4.3	<i>Allowed Lorries</i>	52
7.4.4	<i>Control Parameters</i>	53
7.5	OUTPUT DATA	53
7.5.1	<i>Summary data</i>	53
7.5.2	<i>Intermodal Transport Demand</i>	55
7.5.3	<i>Road Transport Demand</i>	56
7.5.4	<i>Train System Data</i>	58
8	LIST OF VARIABLES AND CONSTRAINTS	60

1 Introduction

This user guide contains a practical guide to using the Heuristics Intermodal Transport model, the HIT-model. It contains the necessary types of input data and their format. It also covers the use of the user interface in Microsoft Access. The heuristics principle used in the HIT-model can be found in the manual entitled “Heuristics”.

The Heuristics Intermodal Transport model takes its starting point in a competitive situation between traditional all-road transport and intermodal transport, where the potential of intermodal transport is assumed to be determined by how well it performs in comparison with all-road transport. The model can also be used as a calculation tool to calculate the costs and environmental effects of a given transport system. The optimisation and calculation functions can also be mixed, where some parts of the transport system design are given by the input data and the remaining parts are optimised.

A transport buyer is supposed to select the mode of transport that offers the best combination of transport quality, cost, and environmental effects. Intermodal transport is also required to match, or outperform, the delivery times offered by all-road transport.

Given a certain demand for transport, the model determines the most appropriate modal split, sets train time tables, type and number of trains, number of rail cars, type of load carriers, etc. and calculates business economic costs, social economic costs and the environmental effects of the transport system. The heuristics can further be controlled by a number of control parameters in order to adjust the behaviour and modal choice of the model. The model is flexible and can be used to test different suggested system layouts, conduct sensitivity analyses, and to test the effect of the intermodal transport system on specific factors, e.g. changed taxes, regulations or infrastructure investments. The model is useful for both large scale national transport systems and small individual transport systems. The model is programmed in C++ and the model size is only limited by available computer memory. Output from the model is the modal choice for each demand occurrence with departure time, arrival time, train departure used, position on train, type of lorry used, number of lorries used, business economic cost, social economic cost, and environmental impact (CO₂, CO, SO₂, NO_x, PM, HC, energy consumption and a monetary estimation). If all-road transport is selected, the model also shows the reason why intermodal transport could not be selected (e.g. violated time constraint, economic constraint, etc.). The suggested train system output presents time tables, train lengths, business economic costs, social economic costs and environmental impact.

1.1 Model heuristics

Very briefly, the heuristics work by comparing the transport cost and quality between intermodal transport and direct road transport. The heuristics first determine the best lorry type to use in intermodal transport and direct road transport, respectively. The heuristics then take the demand occurrence with the highest potential cost saving and try to send it by intermodal transport. If there is no available train capacity, the heuristics check whether it is economically possible to “finance” a new train capacity and still have cost savings compared to direct road transport. The heuristics also consider whether the demand for several departures on the train loop can finance new capacity. If possible, the heuristics insert the new capacity and make it available for the entire train loop. This continues until the economic constraints are violated. The heuristics also check that the delivery time

by intermodal transport is the same, or faster, than that with direct road transport. A full description of the heuristics can be found in the manual “Heuristics”.

1.2 Model background

The Heuristics Intermodal Transport model, the HIT-model, was developed as a part of Jonas Flodén’s doctoral thesis, *Modelling Intermodal Freight Transport – The potential of combined transport in Sweden* (2007)¹. The thesis was presented in the Department of Business Administration at the School of Business, Economics and Law at Göteborg University, Göteborg, Sweden (<http://www.handels.gu.se>).

1.3 Technical Overview

The Heuristics Intermodal Transport model consists of two main parts, the actual calculations model and a user input and output interface. The calculation model is programmed in C++ in the Microsoft Visual Studio.NET 2003 and runs in a DOS window. The user interface is implemented in Microsoft Access. The interface contains database functions to store and format the input and output data and to perform basic analyses of the data. Data is transferred between the two parts by using text files. The input data is formatted into text files by the user interface, which are then read by the calculation model. The output data from the calculation model is formatted into text files by the calculation model, which are then read by the user interface. It is also possible to use other software besides the current user interface to create and read the text files, as long as it follows the same file format. The file formats are available in chapter 7. The model also has a visualisation tool, implemented in the standard Geographical Information System (GIS) software ArcGIS.

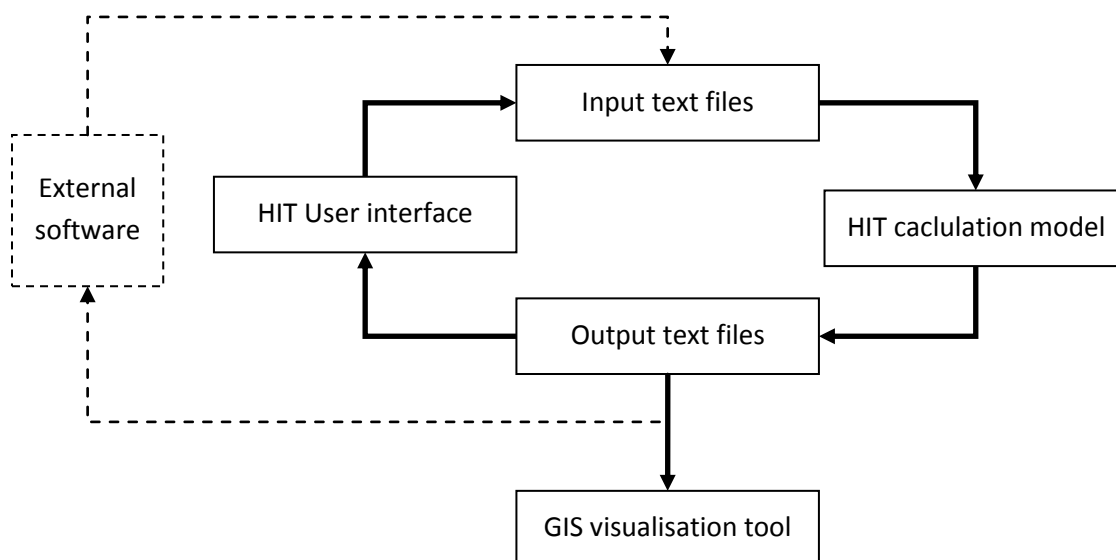

Figure 1 HIT model parts

¹ Flodén, J., 2007, *Modelling intermodal freight transport : the potential of combined transport in Sweden*, Doctoral thesis, Department of Business Administration, School of Business, Economics and Law at University of Gothenburg, BAS Publishing, Göteborg, <http://hdl.handle.net/2077/17141>

The HIT model can be accessed by authorised users from a remote desktop connection to the servers at the School of Business, Economics and Law at the University of Gothenburg.

Microsoft Access 2007, or a later version, is required to run the user interface, and ArcGIS Desktop is required to run the visualisation tool.

1.3.1 Model size allowed

The model is designed to be limited only by the available computer memory. However, computer programs always contain constraints to some extent. The current C++ program is built to be flexible and dynamically allocates memory and resizes the storage structure when needed. However, some constraints are set when the source code is compiled into a running program. For example, the variable that contains lorry type numbers (used to identify the type of lorry, e.g. a trailer lorry is called type 2) is a “short unsigned int” (holds positive integer numbers) with a maximum storage capacity (i.e. the largest number the variable can hold) of 65 535, which means that 65 535 different types of lorries can be used (the variable identifies lorry types, not individual lorries). The variable could easily be extended to, e.g., an “unsigned int” to hold 4 294 967 295, just by changing a few lines in the source code. The possible model size is thus unlimited, but might require the program to be recompiled if extreme models should be run. Since a computer always reserves memory space for the largest possible number in a variable, all computer programs are compiled to hold no more than the expected variable sizes in order to avoid wasting memory. Model recompiling cannot be performed by the model user, as it requires access to the model source code. The maximum variable size allowed in the current compilation of the HIT-model is stated for each input parameter in this user guide. Note that changing the maximum variable size in the source code might require the variables types and validation rules in the user interface in Microsoft Access to be changed.

1.3.2 Model run times

The model run times will, naturally, depend on the size of the transport system being modelled. However, the model run times in previously tested systems have been fairly short. A tested transport system of 500 000 lines of transport demand and 2 000 transport links required between 10 and 25 minutes run time (excluding reading and saving input/output data in the user interface), depending on the settings used in the HIT-model². In general, the more shipments there are, the more train departures that are available to choose from, and the longer the train loops are, the longer the runtimes will be in the model. However, the most important factor is the number of shipments (defined as “demand occurrences” in chapter 1.5).

1.4 What is heuristics?

The HIT-model is a heuristic model. Heuristic models are based around a number of principles, or rules of thumb, that are used to meet the objective of the model. A heuristic model is more flexible and faster than a traditional mathematical optimisation model. When the words optimisation, optimum, etc. are used in this manual, they should be interpreted as indicating the best heuristics solution possible according to the heuristic principles in the model. These are described in the manual called “Heuristics”.

² The model was run on an ordinary desk top PC, an HP Compaq dc7600, 3 GHz Intel Pentium 4 processor and 1 GB RAM memory.

1.5 Definition of Terms and Concepts

Some terms and concepts used in the HIT-model needs to be defined.

1.5.1 All-road transport

The traditional road transport system.

1.5.2 Combined transport

Intermodal transport, where the major part of the journey is by rail, inland waterways or sea and any initial and/or final leg carried out by road is as short as possible.

1.5.3 Demand occurrence

The amount of goods to be transported from demand point A to demand point B at a given time. The demand points are the origin and destination of the goods. The time is the time when the goods is ready to be dispatched.

1.5.4 Demand point

A geographical location that has a demand for transport, e.g. a municipality.

1.5.5 Intermodal transport

The movement of goods in one and the same loading unit or vehicle which uses two or more modes of transport successively without handling the goods themselves in changing modes.

1.5.6 Intermodal terminal

A transshipment centre where goods are transferred between different modes of transport, e.g. from rail transport to road transport. A terminal normally also contains storage facilities for ITUs waiting to be picked up by the next mode, e.g. waiting for the next train to arrive at the terminal.

1.5.7 ITU

Intermodal Transport Unit (ITU). Containers, swap bodies and semi-trailers suitable for intermodal transport. Also known as the load carrier, load(ing) unit or unit load.

1.5.8 Transport link

The connection from A to B, i.e. the origin and the destination for the demand occurrences. Note that A to B and B to A are two different transport links. There can be several demand occurrences on a transport link. See Figure 2.

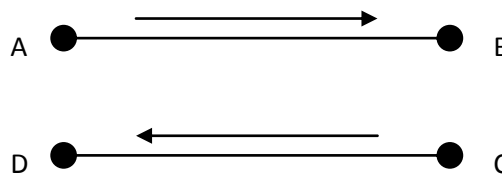

Figure 2 Transport link A to B and transport link C to D

1.5.9 Train route

The connection between two intermodal transport terminals, e.g. from terminal X to terminal Y and from terminal Y to terminal X. Note that X to Y and Y to X are the same train route. See Figure 3.

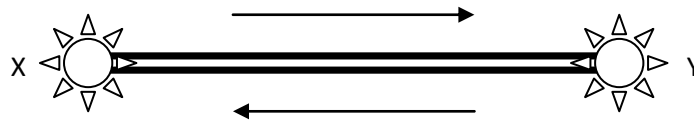

Figure 3

Figure 3 Train route XY

1.5.10 Train loop

A train loop is the movement of a physical train, e.g. depart X at time 1, arrive Y at time 2, depart Y at time 3, arrive X at time 4, etc. See Figure 4. There can be several train loops on one train route and one train loop can operate on several train routes. A train loop must consist of at least one train departure, but normally consists of several train departures. A train departure is the departure of the train from a terminal at a certain point in time

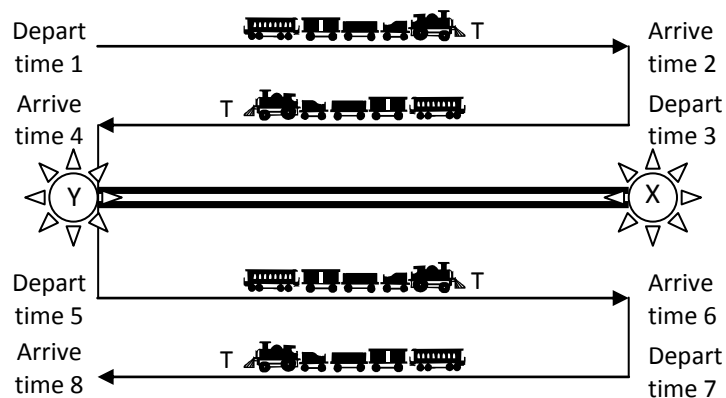

Figure 4 Train loop T

1.5.11 Transshipment

See terminal handling.

1.5.12 Terminal

See Intermodal terminal.

1.5.13 Terminal handling

Activities performed at an intermodal terminal to transfer an ITU between different modes.

2 User interface in Microsoft Access

The user interface has been developed using the software Microsoft Office Access, and requires Microsoft Access to run. Microsoft Office Access is a common standard database software and is a part of the Microsoft Office software family. A database software is specially designed to handle and structure large amounts of data. Microsoft Access is widely available and, on many computers, the software has been automatically installed together with the other parts of the Office family, e.g. Microsoft Word and Excel. The user interface has been developed in version 2007 of Microsoft Access and can be found in the file *HIT-model.accdb*. The intention of this user guide is not to give detailed instructions on how to use Microsoft Access in general, but to focus on the specific HIT-model user interface. Manual and user guides for Microsoft Access in general can be found in any number of books and on the Microsoft homepage³.

2.1 What is a database?

A database is a collection of data stored together and related to each other. In a database, data is stored in tables, called files. Each table contains a number of columns, also called fields, e.g. weight, time or a geographical destination. Each row in the table represents a record, e.g. all data concerning a geographical location or a type of lorry. Each table consists of a collection of records, e.g. all geographical locations. For example, the table for the demand for transport contains the fields Origin, Destination, Time and Weight. Each record will represent one individual demand occurrence. Together, all records will form the Demand table. The tables can then be linked to together to form a database, e.g. linking demand for transport to geographical locations.

Databases are specifically designed to handle large amounts of data. Since the data is related to each other, it is possible to conduct analyses linking different tables and fields together. It is also possible to sort and select records matching certain criteria, e.g. find all demand occurrences from Stockholm with a weight over 20 tonnes and that are sent by train.

2.2 User interface technical information

The security setting must be set to allow macros to be run in order for the user interface to work properly. Normally, Microsoft Access will ask about the security settings when opening a database containing macros. In the HIT-model, macros are used to load and save data from the calculation model. Macros can be disabled if loading and saving of data to the calculation model is not required. The security setting for macros in Microsoft Access can be set in Access Trust Center, which can be found under the Access options menu.

The calculation model uses a dot (.) as decimal point, unlike the Swedish standard which uses comma (,). When using Microsoft Access, or other software, to generate the input files, it must be remembered that most programs adapt the decimal point to the local system settings, e.g. a comma instead of a decimal point in Sweden. In Microsoft Access, these settings can be changed in the Options menu.

When modelling large transport systems, the amount of data that needs to be entered can be large. It is possible to import data from other databases, Excel files or text files directly into Microsoft

³ <http://office.microsoft.com/access>

Access. This can be done under the *External data* tab in Access. See any Microsoft Access book, help file or user guide for more instructions.

2.2.1 Field sizes

There is a limit on the size of the numbers that can be stored in a field in a Microsoft Access database. The field sizes used in the user interface have been set to match the field sizes allowed in the calculation part of the HIT-model. See chapter 8. If the available field sizes in Access do not exactly match the field size in the calculation model, then a validation formula has been included that shows a warning if the user tries to input a unallowable value. There is a difference in how computers store integer values and decimal values. This applies both to the Access interface and the calculation model. See chapter 10.

Decimal input values are displayed as ordinary decimal numbers in the forms. However, if the advanced user should look at the underlying tables, decimal numbers are shown using scientific notation, e.g. 5.89E-03 instead of 0.00589. The reason for this is that there is a bug in Microsoft Access, causing it to cut all decimal values to two decimals when exporting to a text file⁴, e.g. 2.543368 is exported as 2.54. However, when exporting as a scientific value, then all decimals are included. Note that this only applies when exporting data from Microsoft Access. When reading output data files into Access from the calculation model, then all decimals are read.

⁴ Microsoft support document *Exporting to Text File Truncates to Two Decimals Places*
<http://support.microsoft.com/kb/208408/en-us>

3 Using the HIT-model

The HIT-model is operated from the user interface, accessed through the remote desktop connection.

3.1 Working with the user interface

The user interface contains a number of screens with buttons and fill-in forms, so-called Forms. The forms are intended to simplify the use and input of data. However, the data can also be viewed as the original Tables, where the data is displayed as a table similar to how it would look in Excel. The user interface also uses a number of Queries and Macros. A Query is a question asked to the database, e.g. to find some specific data, calculate something, combine data from several tables, etc. A macro automates a number of tasks in the user interface, e.g. load and save input data files. The macros are activated through buttons in the forms. All tables, forms, queries and macros can also be accessed directly through the menus in Microsoft Access. The menus are, as in all Microsoft Office programs, accessible through a number of tabs at the top of the screen.

Note that when working with a database, any changes in the data are automatically saved directly when a table or form is closed.

The user interface is opened by the file *HIT-model.accdb*. Normally, the computer will display a security warning at the top of the screen when opening the user interface. Select *Enable this content* to use the full user interface. See chapter 2.2.

Microsoft Access uses a *Navigation Pane* to the left of the screen to navigate between different forms, queries, tables etc. See Figure 5. The user interface has been designed so that a normal user only needs to use forms in the database. If the Navigation Pane does not open automatically when the database is opened, it can be opened by clicking on the small arrow in the top left side of the screen.

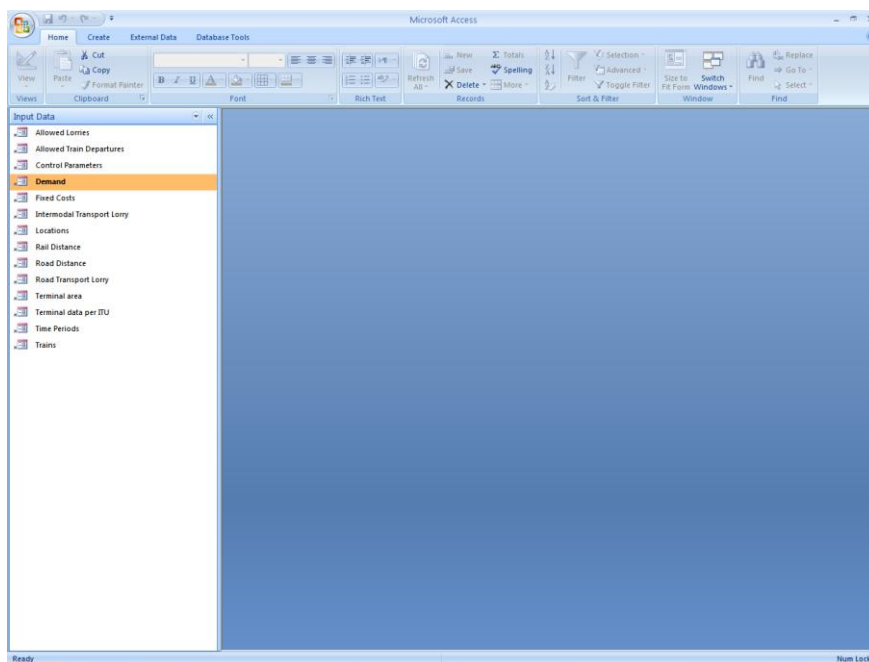

Figure 5 Microsoft Access main screen

The Navigation Pane contains links to a number of forms in the user interface. The forms are organised in groups. Click on the small down arrow on the top of the Navigation Pane to select between the different groups. See Figure 6. The menu shown is divided in two parts. The top part, *Navigate to Category*, selects between different main categories. Select the HIT-model to work with the HIT-model user interface. The bottom part, *Filter by Group*, selects which sub-group to work with. The sub-groups in the HIT-model are:

- Input data
- General data
- Output data
- HIT-Model Control Functions
- Analyses

Click on any sub-group to select it.

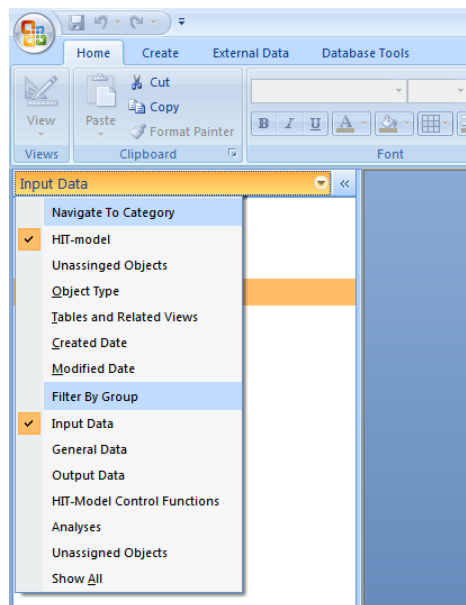

Figure 6 Close-up on Navigation Pane with open menu

When a sub-group has been selected, the Navigation Pane shows the available forms for that subgroup. See Figure 7.

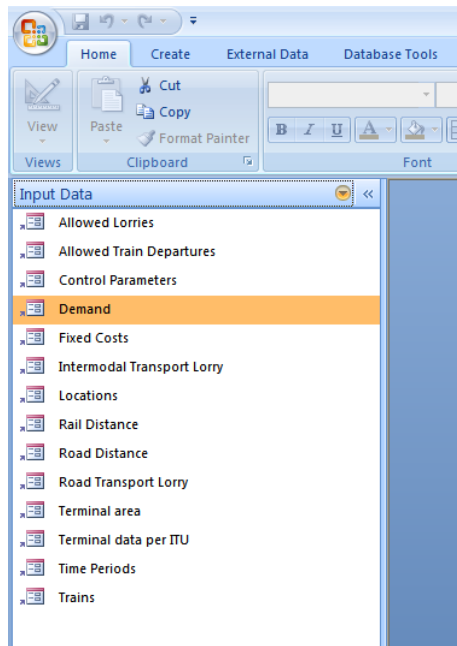

Figure 7 Close-up on Navigation Pane with sub-group Input data

Click on any of the forms to open it. As an example, the form to input demand data is shown in Figure 8. Each form will be explained in detail in the following chapters. Each form will be opened as a new window in Microsoft Access. Note that previously opened windows are not automatically closed when a new window is opened. The user must remember to close unwanted windows, since a large number of open windows will slow down the program. The windows can be managed by the button *Switch Windows* in the Microsoft Access *Home*-tab.

The form consists of fill-in boxes where input data can be reviewed and input⁵. Some forms contains sub-forms where data from other forms are displayed. In the form in Figure 8, sub-forms are used to display additional data for the geographical locations. At the bottom of the screen are the record selectors⁶. To change records, either use the keyboard keys *Page Up* and *Page Down*, or the left and right arrows in the record selector. The arrow with a straight vertical line at the end selects the last or first record in the database. The arrow with a yellow star adds a new empty record to the database.

⁵ Large amount of data can be imported directly into Microsoft Access using Excel or any other general data file. See any book on Microsoft Access for further instructions.

⁶ A record is a group of connected data, e.g. a demand occurrence or data for a geographical location. For example, in an address book, the data concerning each person (e.g. name, address, telephone number) would be considered a record.

Figure 8 Example of a form

Each form can also be viewed as a table or as pivot chart or graphs. The button near the top left corner selects between different views. See Figure 9.

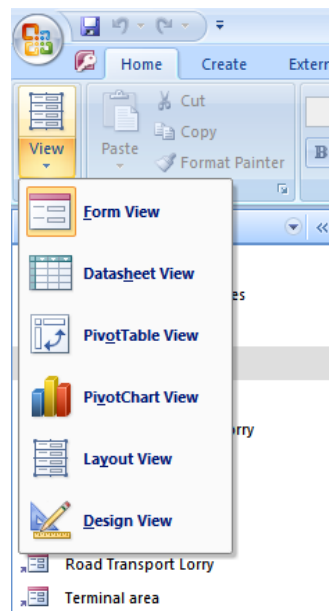

Figure 9 Select different views

Form View is the normal view to work with the database. *Datasheet View* displays the data as a table. See Figure 10.

From	To	Time	Weight
643	428	1	3
180	1480	2	22
114	20	6	980
114	44	6	980
114	44	7	305
1486	704	7	136
1486	716	7	136
1486	692	7	136
1486	740	7	136
1486	788	7	136
114	20	7	305
1486	812	7	136
114	44	10	183
114	20	10	183
1486	692	10	1480
1486	716	10	1480
1486	812	10	1480
1486	704	10	1480
1486	740	10	1480
1486	788	10	1480
114	40	13	980
114	20	13	180
114	44	13	180
1486	808	14	136
1486	700	14	136
114	16	14	305
1486	784	14	136
1486	736	14	136
114	40	14	305
1486	712	14	136
114	12	17	980
114	36	17	980
114	36	18	305
114	12	18	305
114	32	18	980
1486	708	18	136
114	6	18	980
180	181	18	222
1486	804	18	136
1486	756	18	136

Figure 10 Data sheet view

The data can also be displayed as a pivot table or pivot graph by selecting that view. A pivot view displays data summarised into groups, e.g. total demand per destination. A pivot table or pivot chart is created by dragging and dropping the field names in the appropriate boxes displayed on the screen when selecting a pivot view. Figure 11 shows a pivot table of the demand table where From and To destination⁷ are on the X and Y axis and the weight are shown for each time and summarised in the table.

From	Time	8	12	16	20	32	36	40	44	181	428
114	6					980				980	
114	7					305				305	
114	10					183				183	
114	13					180			980	180	
114	14				305				305		
114	17			980				980			
114	18		980	305			980	305			
114	19		305				305				
114	20					1880					1880
114	21				183					183	
114	27				183	180			183	180	
114	29		183								
114	35			180					180		
114	37			180							
114	40				1880					1880	
114	53				1880			1880			
114	56		1880					1880			
114	Total		3528	3528	2548	3528	1285	3528	3528	3528	
180	2										222
180	18										222
180	20										222
180	232										23
180	Total										245
643	1										
643	Total										
1482	23										100
1482	111										121
1482	Total										221
1486	7										

Figure 11 Pivot table of the demand form

⁷ The destinations are identified by an ID-number.

It is also possible to sort and filter the data in all views. This is done in the *Sort & Filter* area in the *Home* tab. All other Access functions can, naturally, be used in the user interface. A user can thus create any number of queries, tables, graphs, views etc. to further analyse the database. Microsoft Access is a very powerful program that analyses databases and can answer most questions related to the data and how the data is connected to itself. It is highly recommended for a user to further study the capabilities of Access. See any Microsoft Access book, help file or user guide for more information on how to use Microsoft Access.

3.2 User interface structure

The user interface consists of five sub-groups of forms. The groups are Input data, General data, Output data, HIT-model control functions and Analyses. The groups are selected in the Navigation Pane on the left side of the screen. Input data and output data groups consists of the input data to the model and the output data from the model. The analyses group consists of aggregations, links between different output data, summaries etc. The general data group consists of data that is used in the user interface but is not input in the calculation mode, e.g. name and addresses of locations. The data in this group is voluntary. The group HIT-model control functions consists of functions to control the model, e.g. to start the calculation model, save files etc. Each group is explained in more detail in the following chapters.

3.3 HIT-model control functions

The control function consist of one form with a number of buttons to run the calculation model, load and save data and display the summary data file. See Figure 12. The calculation model is run by pressing the big *Run Calculation Model* button at the top of the screen. This will display a black DOS window showing the progress of the calculations. See Figure 13. Remember to first save the input data to the calculation model by pressing the *Export all data to model runs* button below. This will save all input data in the Input group to the text files used by the calculation mode. See chapter 7.1. Any previous input data text files will be automatically deleted. After the calculation model has finished, the output data can be loaded into the user interface by pressing the *Load all data from model run* button. This will read the output text files from the calculation model and import them into the user interface database. All previous output data in the user interface will be automatically deleted. Each individual input and output file can also be saved or imported by pressing the buttons at the lower part of the screen. See chapter 7 for a definition of each file.

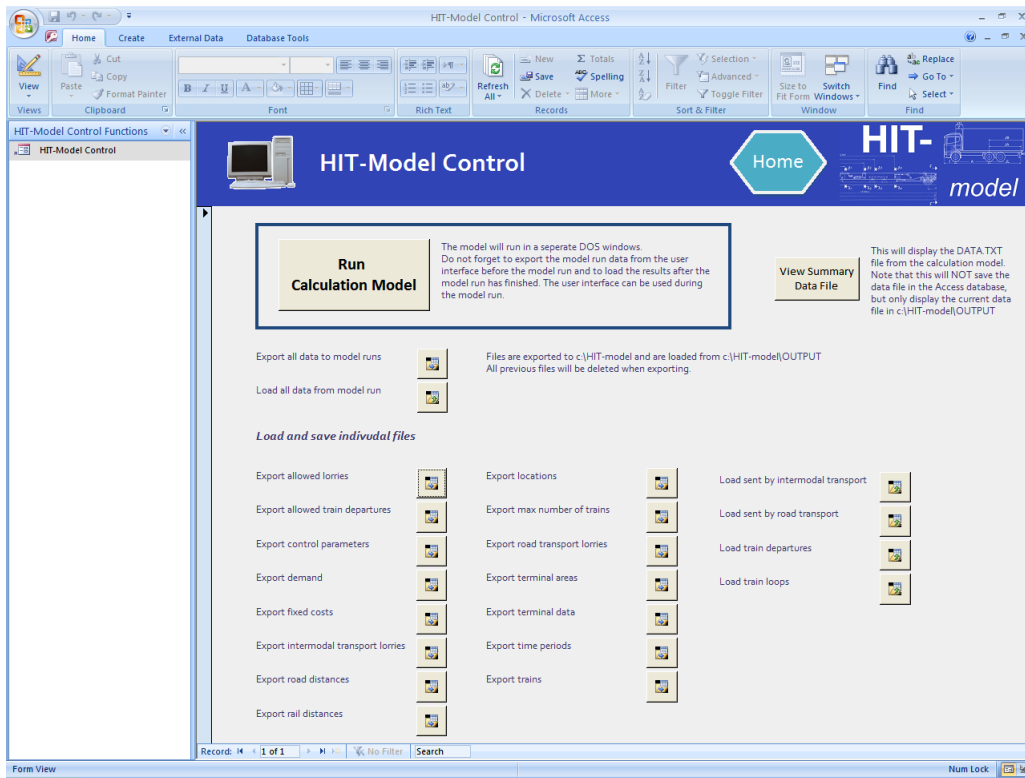

Figure 12 HIT-model control form

The calculation model also outputs a summary data file. This file contains a short summary of the model run, including model run date, run time, parameter settings used, modal split and summary output results for key variables. The file also contains warnings if anything has affected the model heuristics. See chapter 7.5.1. The summary data file is imported into the user interface, but can also be displayed by pressing the *View Summary Data File* button for a quick overview of the latest model run. This displays the current file on the hard drive and not the file loaded into to user interface.

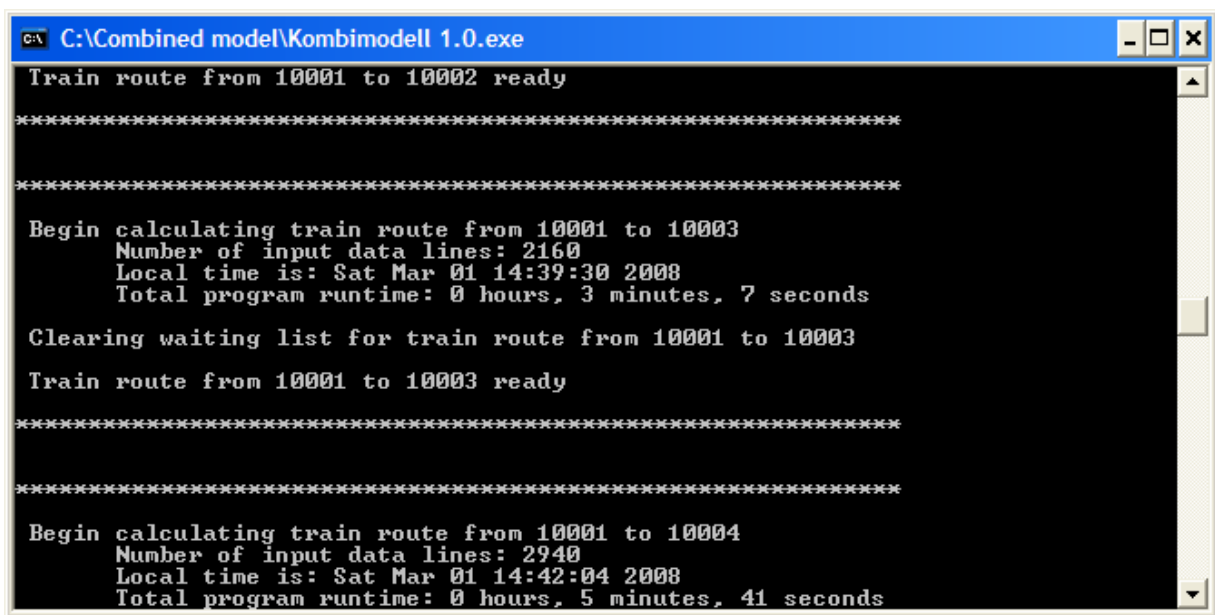

Figure 13 Calculation model window

3.4 General data

The general data group contains the data used in the user interface to simplify the use of the interface by, e.g. displaying the full name of a geographical location instead of just the number used in the calculation model. The data in the general data group is thus not used in the calculation model and is voluntary to input. The group consists of five forms:

- Demand Locations
- Locations
- Number of Days in Model Run
- Terminals and Train Routes

The Demand Locations form shows data concerning each demand location, e.g. full name, address, municipality code, addresses etc. The Terminals form shows similar information for each terminal. The demand locations and terminals are combined in the Locations form, which shows all locations in one form. More fields can be added to the table in Microsoft Access, if necessary. All train routes are shown in the Train routes form. The Number of Days in Model Run shows the number of days that the model run covers. This is used in the user interface to calculate output data per day, e.g. cost per day.

4 Input data

This chapter covers the input data used in the HIT-model. The user interface group Input data consists of 15 forms. The data in this chapter is used by the calculation model. Brief descriptions of the input variables and how to use the user interface are given here. A description of the file names and file format are given in chapter 7.1. There is also a list of all variables in chapter 8. The variable sizes shown are for the current compilation of the HIT-model and can be changed. For details, see chapter 1.3.1.

The input data consists of

- transport demand
- road distances
- rail distances
- terminal areas
- terminal data
- train types
- all-road lorry types
- intermodal transport lorry types
- allowed train loops
- allowed lorries
- time periods
- control parameters

4.1 Transport network and demand

The basis for the HIT-model is the transport network and the demand for transport. The transport network defines the geographical parameters to which the transport system has to be confined. The transport network is defined by the number of geographical locations between which there is a demand for transport.

4.1.1 Geographical locations

The geographical locations in the HIT-model are each identified by a unique integer number. Their geographical position is determined by its distance to other geographical locations, e.g. location A is 50km from location B and 25 km from location C. Thus, the HIT-model uses a pre-calculated table of distances between all geographical locations. The geographical locations used in the model are demand points and terminals. A demand point is a geographical location that has a demand for transport.

The geographical locations are identified and input into the model when transport demand, distances and terminals are input into the model. Thus, as soon as a geographical location is used in the input data, it is also added to the model. There is no separate input list of locations.

The transport links are input and made available in the model when the distances are input.

4.1.1.1 User Interface

Although the calculation part of the HIT-model does not use a separate input list for geographical locations, the user interface contains such lists for analyses and record purposes. The lists are explained in chapter 3.4 General data. Note that the data from these tables are never input in the

calculation model, but are only used to identify the geographical locations in analyses, etc. The use of these tables are voluntary.

4.1.1.2 Constraints

Each geographical location must have a unique number. Note that the same number series is used for both demand points and terminals. Thus, a demand point and a terminal cannot have the same number. The numbers are set by the user.

Distances must be input between all geographical locations used. See chapter 4.1.3 and 4.1.4.

The range of numbers that can be used to identify a geographical location are integer numbers from 1 to 65 535. Terminal locations can only use numbers from 1 to 21 474. See chapter 4.2.4.2.

4.1.2 Transport Demand

Transport demand is the demand for transport. It is input as:

- origin
- destination
- weight to transport
- time ready for transport

This is the demand for which the modal split shall be determined. This is called a demand occurrence and can represent anything from an individual shipment to an aggregation of shipments, depending on the modelling needs and data quality available. For example, smaller shipments in the general cargo system might be included after they have been collected and aggregated to larger shipments (since this phase is the same for both intermodal transport and all-road transport) while in other situations it might be more appropriate to aggregate all demands on a common geographical level. Note that the model does not aggregate or combine any demand occurrences. Each demand occurrence is treated separately and sent by separate lorries, even if they are sent on the same transport link at the same time.

The sending and receiving locations represent the geographical locations between which the required goods should be transported. The time can be set freely to any value for each demand occurrence. This is the time the demand occurrence is ready to depart from the sending location. Any weight equivalent can be used as long as lorry capacity is defined in the same unit, as the model converts the demand occurrence to a number of lorries.

During the model run, each demand occurrence can be split between several different train departures, and also between all-road transport and intermodal transport. However, an individual lorry and its ITUs cannot be split, since this is not realistic. Thus, all ITUs on a lorry are kept together.

The geographical locations are input using positive integer numbers. See chapter 4.1. Demand is input using positive integer numbers and time is input using decimal numbers. Note that time is input using a decimal system. Half past ten in the evening (i.e. 10.30 p.m.) is input as 22.5 (if hours are used to measure time). A continuous time numbering is used over all days in the modelling period, i.e. at 8 a.m., day two is input as 32 (24 hours + 8 hours). This is to simplify the mathematical calculations. More about time in the HIT-model can be found in chapter 4.3.1.

4.1.2.1 Constraints

The largest number that can be used to represent demand is 4 294 967 295⁸. Note that the largest number that can be used when using the user interface in Microsoft Access is 2 147 483 647.

Time is input using a decimal system with non-negative values.

4.1.2.2 User Interface

Demand is input in the Demand form. The form contains the demand variables, but also a link to the Locations form to show additional data for each location. The bottom half of the form shows the data from the Locations forms. See Figure 14.

Figure 14 The Demand form

4.1.3 Road distances

The distance is input between all geographical locations used in the model. This is used to calculate transport times and distance dependent costs. The data is input as

- to location
- from location
- distance

The location is input using the integer location numbers described in chapter 4.1. Distance is input using a positive integer number. Note that the distance between A and B and between B and A are input as two separate distances, which might be different. Remember that road distances must also be input to and from the terminals for all locations.

⁸ This is for each demand occurrence. The HIT-model also calculates some summary values, e.g. total demand on each train departure, total demand sent by intermodal transport etc. These variables also have the same storage capacity. Trying to store a larger number in the variables will cause them to overflow and contain a random number. However, these summary variables do not affect the heuristics in any way

4.1.3.1 User Interface

Road distances are input in the Road Distance form. As with the demand form, the bottom half of the screen shows additional information about the locations.

4.1.3.2 Constraints

A distance must be input between all locations used in the model and in both directions, even if no transport demand exists on that transport link⁹. This includes inputting the distance to and from the same location as 0.

The largest number that can be used as a distance is 4 294 967 295. Note that the largest number that can be used when using the user interface in Microsoft Access is 2 147 483 647.

4.1.4 Rail distances

Rail distances are input between all terminals in the model. The distance is used to calculate transport times and distance-dependent cost. As with road distances, the data is input to and from the destination and the distance. The input of rail distances follows the same principle as for road distances, described in chapter 4.1.3.

4.1.4.1 User Interface

Rail distances are input in the Rail Distance form. As with the demand form, the bottom half of the screen shows additional information about the locations.

4.1.4.2 Constraints

A distance must be input between all terminals in the model and in both directions. This includes inputting the distance to and from the same terminal to 0.

The largest number that can be used as a distance is 4 294 967 295. Note that the largest number that can be used when employing the user interface in Microsoft Access is 2 147 483 647.

4.1.5 Terminal Areas

The terminal area is the terminal to which each demand point is assigned. Normally, this would be the closest terminal. The intermodal transport from that demand point is always sent through that terminal. The terminal area is input as the number of the demand point and the number of the terminal it is assigned to. The terminal number is input as a positive integer.

4.1.5.1 User Interface

The terminal area is input in the Terminal Area form. The bottom half of the screen shows additional information about the locations.

4.1.5.2 Constraints

Each demand point must be assigned to a terminal. Terminals can be identified by integer numbers from 1 to 65 535.

4.2 Cost and Environment

Costs in the transport industry can, as in most other industries, be divided into fixed costs and variable costs. Furthermore, the costs can be allocated to specific cost units, e.g. a lorry, or considered as common shared costs for the entire system, e.g. general administration. The HIT-

⁹ The calculation model uses the structure created by the distance data to store and find all geographical data.

model follows this division into fixed and variable costs, and common and separable costs. Separable costs are input for lorries and trains as costs variable by time and distance. Separable costs are also input per terminal handling. Fixed and common costs are input for entire transport systems or train routes. Costs are input for both business economic costs and societal economic costs. The societal economic cost evaluation takes into consideration the effects of transport on all parts of the society, e.g. the external cost of pollution. Society, in this perspective, includes not only the government and public sectors, but all citizens and companies in society.

Note that if an economic cost optimisation is performed, then social economic costs do not necessarily have to be input, and vice versa. The HIT-model only considered either business economic costs or social economic costs in the heuristic optimisation process. The other costs are only calculated as optional output data.

The HIT-model also calculates the environmental effects of the transport system. The environmental effects are calculated for

- carbon dioxide (CO₂)
- carbon monoxide (CO)
- sulphur dioxide (SO₂)
- nitrogen oxides (NO_x)
- particles (PM)
- hydrocarbons (HC)
- energy consumption

The effects are calculated according to the same principle as for the economic costs described above. They are all considered to be distance dependent, except for terminal handling, which is considered to be incurred instantly.

The fact that emissions can be treated in the same way as costs makes it possible to enact direct environmental optimisations simply by switching variables in the input data, e.g. by inputting CO₂ emission data in the cost variables. The emission variables can also be used to represent any other distance dependent emission. The emissions mentioned above are only the names of the variables. The costs and environmental data are input using decimal numbers.

4.2.1 Lorries

The type of lorry being used has grown increasingly important when comparing road transport and intermodal transport. The introduction of longer and heavier lorries has, for example, increased the competitiveness of all-road transport, since the added marginal cost of running a bigger lorry is rather small. This also means that it has become important to include the type of lorry in the modelling. The HIT-model can handle a large number of different lorry types. The HIT-model heuristics will, in brief¹⁰, select the best type of lorry to use for all-road transport and the best lorry type to use for intermodal transport from a list of allowed lorry types. The selection is made for each individual demand occurrence. The lorry type selected is the type that gives the lowest total transport cost for the current demand occurrence. An integer number of lorries are used, i.e. if the capacity of 1.2 lorries is needed to transport the demand occurrence, then 2 lorries are used. For

¹⁰ See the manual entitled Heuristics for a full description.

example, if a demand occurrence requires 1.4 lorries of type A at a cost of 50 each (i.e. cost 100) or 1.7 lorries of type B at a cost of 60 each (i.e. cost 120), then 2 type A lorries are selected as the best lorry option. It is possible to include constraints on the number and types of lorries that are available for a certain demand occurrence at a certain time. See chapter 4.3.3.

The lorries are input with their:

- loading capacity
- business economic cost per distance unit
- business economic cost per time unit
- societal cost per distance
- societal cost per distance
- average speed
- the environmental effects
- lorry type number
- length on rail car (for intermodal lorries)

Each lorry type is identified by a type number. The type number is used in the output data to identify the lorry type selected by the HIT-model. For intermodal transport lorries, the length that the ITUs on one lorry occupy on a rail car is also included. The need for rail cars is represented in the model by the length of the rail car required by each lorry type. This will also make it possible to give a better representation of the requirements of different ITUs in the rail system, since the lengths required are separate from the actual length of the ITU. A heavy ITU could, for example, be defined as needing the length of an entire rail car to represent weight restrictions. Similarly, a trailer could be defined as using an entire rail car even if the trailer itself is shorter, as is normally the case with trailers. ITUs with a low load factor¹¹ or low-density goods will also be better represented. Note that the length required is for all ITUs on the lorry, as the ITUs on a lorry are not allowed to be separated between different trains.

The HIT-model used two separate lists for all-road transport lorries and intermodal transport lorries. If the same lorry type is used in both all-road transport and intermodal transport, it must be input for both modes. The lorry type number must be unique for each transport mode, but the same number can be used in the different modes.

Note that the costs and environmental effects incurred at the terminals are input for each terminal, see chapter 4.2.3.

Speed, loading capacity, lorry type and length required on rail car are input using a positive integer values¹². All other data is input using decimal numbers.

4.2.1.1 User Interface

The lorries used for all-road transport and the lorries for intermodal transport are input in two different forms. The forms are the Road Transport Lorry and the Intermodal Transport Lorry.

¹¹ A low load factor can be represented by stating a lower maximum load for lorries in certain transport relations and time periods.

¹² Length must use an integer value, e.g. centimeters, since an exact number is needed to match the available train capacity. See chapter 0.

4.2.1.2 Constraints

The largest allowed lorry type number and lorry speed is 65 535. Each intermodal transport lorry type and an all-road lorry type must be given a unique number. Note that the number series are separate, so the same number can be used for both all-road lorries and intermodal transport lorries.

The largest allowed loading capacity and length required on a rail car are 4 294 967 295. Positive numbers must be used. Note that the largest number that can be used when using the user interface in Microsoft Access is 2 147 483 647.

4.2.2 Train Types

The train types are input as:

- business economic cost
- societal economic cost
- capacity
- the environmental effect
- speed
- train type number

Capacity is set as maximum train length. Cost data divided into:

- cost for new train
- new empty rail car unit on train
- transporting something on a rail car unit

The costs for using a new train are divided into three steps. First, the costs to add a new train to a train loop; second, the costs to add a new rail car to the train; and third, the costs to use the rail car, i.e. run the rail car with something loaded on it. Since the model shall be able to determine the number of trains and train lengths that should be used, a correct cost representation to use in the modal choice must include the obvious fact that it is more expensive to add a new train (with a single rail car) to a train loop than to add the new rail car to an already existing train¹³. This cost structure enables the model to represent the higher cost (per rail car) to run a short train and ensures that no trains are added to the model until the start-up costs for the new train are compensated. This is particularly important when running long train loops, as any new train is assumed to be inserted on the entire train route, thus incurring high start-up costs for a long train loop. The three cost levels are aggregated to form the total cost¹⁴. Costs are input as both business economic costs and societal economic costs. Cost and emissions are input as decimal numbers. Capacity, speed and train type numbers are input as integer numbers.

4.2.2.1 User Interface

Train data is input in the Trains form.

¹³ This can also be seen by the stepwise increasing cost curve in the heuristics. See the manual entitled Heuristics for a full description.

¹⁴ The cost to run a train with ten rail cars, of which seven are loaded, is thus: Cost for new train + cost for new rail car * 10 + cost to use a rail car * 7.

4.2.2.2 Constraints

Speed and train type number can be any integer number between 0 and 65 535. The largest allowed maximum capacity is 4 294 967 295. Note that the largest number that can be used when using the user interface in Microsoft Access is 2 147 483 647. The data must be input for each train type used in the input train timetables. See chapter 4.3.2.

4.2.3 Terminal Data

The costs and environmental data for the activities at each terminal are also input in the model. Handling costs are input for each lorry type at the terminal. Note that the data represents the total cost to handle one lorry at the terminal, and could thus include the handling costs for several ITUs, if the lorry consists of more than one ITU. The data input are the:

- fixed cost per terminal handling, in business economic cost
- fixed cost per terminal handling, in societal economic cost
- the environmental effect

The common fixed terminal costs, e.g. general administration and land rent, are input as a common fixed cost. See chapter 4.2.4. Cost and emission data are input as decimal numbers. The terminal number is input as a positive integer.

Terminal capacity is not considered, since the necessary terminal capacity can be calculated from the output of the model. It is assumed in the model that the terminal has the capacity to handle all ITUs without delay. The needed terminal capacity will thus be an output from the model and not a constraint.

4.2.3.1 User Interface

The terminal data is input in the Terminal Data per Lorry form. Each view of the form inputs the data for one lorry type at one terminal. Additional information about the terminal is shown to the left on the screen. A list of all the lorries, and their data, that have been input on the current terminal are shown at the bottom of the screen.

4.2.3.2 Constraints

Terminals can be identified by integer numbers from 1 to 65 535. Data must be input for each lorry type occurring at the terminal.

4.2.4 Common Fixed Costs

The common fixed costs are input as:

- business economic common fixed costs
- societal economic common fixed costs
- environmental effect

The data is input for each train route, or the entire system if a total system optimisation is selected. In the event that common fixed costs are present in the intermodal transport system that cannot be allocated to individual ITUs, these costs must be considered jointly for the rail transport system, e.g. rent for a terminal. These fixed costs must be added to the aggregated transport system costs as a lump sum at the start of the model run, since the modal choice is based on the aggregated cost and cost saving. These costs are thus never allocated to individual ITUs. If an optimisation for each train

route is selected, the common costs must be separated for each train route¹⁵. Thus, if several train routes use the same shared fixed resources, e.g. several train routes using the same terminal, a division of the common fixed costs among them must be done externally in the model input. The costs must, therefore, be known at the start of the model run¹⁶. If a total system optimization is selected, then the heuristics consider the total aggregated costs for the entire system. No division between different train routes is necessary, however, because data can be input separately for each train route and will then be summed up by the HIT-model. Costs and emission data are input as decimal numbers.

Train routes are input as integer numbers. Train route numbers are defined as the number of the two terminals involved in the train route, starting with the smallest number. E.g. the train route between terminals 10003 and 10001 is called 1000110003. This number format is automatically generated within the HIT-model and must be followed in the input data.

4.2.4.1 User Interface

The common fixed costs are input in the form Fixed Costs. At the bottom of the screen is additional information about the train route.

4.2.4.2 Constraints

Train routes can be identified by integer numbers from -2 147 483 648 to +2 147 483 647 and must follow the format described in chapter 4.2.4. This means that the largest number use for terminal locations can be 21 474¹⁷.

Fixed terminal costs must be input for all terminals, but they can be input as zero.

4.3 Settings and Transport Framework

There are a number of settings that can be made to define the framework for the transport system and to control the behaviour of the model.

4.3.1 Time periods

The time periods are used to compare delivery times. The modal choice in the HIT-model is based around the fact that the intermodal transport must match or outperform the delivery times offered by all-road transport, while also offering a lower transport cost. See chapter 1.1.

Time has become an increasingly important factor in the transport industry. However, the importance of on-time deliveries should not be confused with a need for faster transport. The transport company often has an agreed time window within which the delivery should be made, e.g. between 9 a.m. and 9.30 a.m., or at sometime during the day. The time windows can vary greatly in length. Short time windows often create planning and capacity constraints when receiving the goods, e.g. a limited number of loading docks and personnel, where the important aspect is the on-time delivery and not the transport time. It is thus important to know exactly when the goods will arrive,

¹⁵ It should be noted that this is conflict with the basic definition of a common cost as a cost that cannot be separated.

¹⁶ If the model output should result in that no combined transport is used on a train route where a fixed terminal cost is inserted, a new allocation of the fixed costs should be done and the model re-run with the fixed costs removed for that train route and no combined transport allowed for the train route.

¹⁷ 83 648 can be used for one of the terminals if the other one is less than 21 747.

but less important to know, e.g., if it is in the morning or in the afternoon¹⁸. Thus, there is a difference between the agreed delivery time window and the greater potential time window in which the delivery time window can be situated, e.g. the delivery should be made sometime during the next day (potential time window) and it is agreed to that the material should be delivered between 9.00 and 9.30 (delivery time window). The agreed delivery time window is a matter of negotiation between the transport company and receiving company. From a modelling perspective it is the greater potential time period that is of interest.

There is also a difference between delivery times (i.e. when the goods is delivered to the receiver) and transport times (i.e. the time needed to perform the actual transport) which is very important to include in the modal choice in the model. An overnight transport might, for example, arrive at the receiver at 4 a.m., but if the receiving company is closed and cannot receive the shipment until 8 a.m., then the delivery time must be regarded as 8 a.m. This is particularly important when comparing road transport and intermodal transport in Sweden, since much of the competition occurs on overnight transport. The longer transport times in intermodal transport, compared to all-road transport, can be absorbed by the later delivery times.

One of the modal choice criteria in the HIT-model is that intermodal transport must match or outperform the delivery times in all-road transport. The comparison is, thus, relative to all-road transport. However, as shown above, a comparison between the delivery times cannot be made directly minute by minute, as it is not often that e.g. 5 minutes matters to a delivery. . A later delivery by intermodal transport is, thus, not necessarily a delay, but can in many cases be regarded as an equivalent delivery time. Three alternative modelling methods will be used to represent this: delivery time windows, time overlap or comparative delivery time gaps. The methods can be used individually or simultaneously.

Note that the time periods used to define the allowed lorries are set as completely separate from the time periods used to compare delivery and departure times. Thus, the allowed lorry types must not in any way follow the time periods used to compare delivery and departure times. See chapter 4.3.3.

4.3.1.1 Delivery Time Windows

Delivery times are compared by means of user defined delivery time windows for each transport relation. A time window is a certain time period, e.g. from 8 am to 10 am. User defined means that it is set by the model user in the input data. This means that if intermodal transport can deliver a shipment in the same time window as all-road transport, then the transport modes are considered to have equivalent delivery times. As the modal choice requires intermodal transport to match or outperform all-road transport, intermodal transport is also allowed to arrive in a previous time period¹⁹. In Figure 15, both all-road transport and intermodal transport can deliver the shipment within the same time window. Road transport delivers first, but intermodal transport also delivers before the end of the time period. Thus, both modes have equivalent delivery times for the shipment; the intermodal transport must match the modal choice criteria or outperform the delivery time by which all-road transport delivers.

¹⁸ Naturally, there are goods flows where the exact delivery time is important, e.g. in JIT-flows for the car industry.

¹⁹ In reality, earlier delivery times could always be arranged to match later all-road delivery simply by delaying the goods at the terminal.

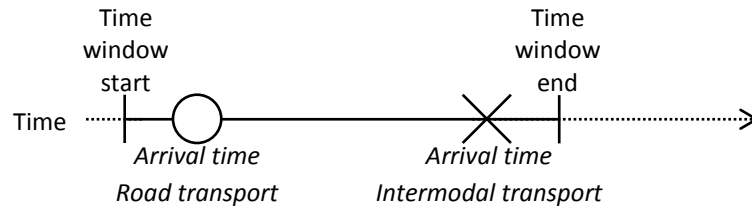

Figure 15 Delivery time windows

4.3.1.2 Time window overlap

The delivery time windows can further be set to allow an overlap between two time windows. This is done independently of the time windows above. The overlap is a period of time between two adjacent time windows that is shared between the windows. When all-road transport arrives in a time window, this time period is extended with the overlap, i.e. extending the allowed time window for intermodal transport²⁰. See Figure 16 where intermodal transport and all-road transport are considered to have equivalent delivery times.

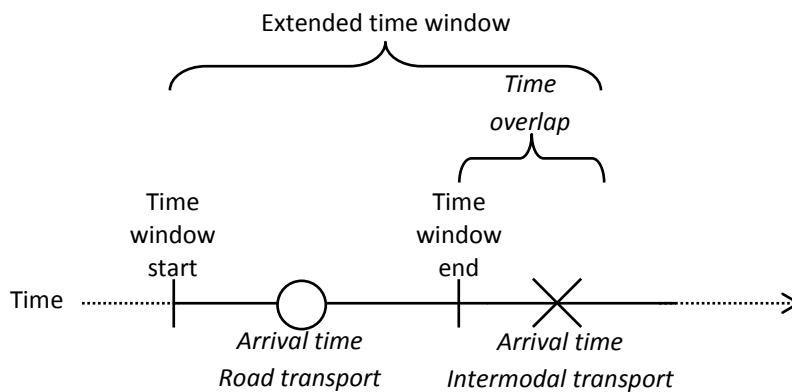

Figure 16 Time window overlap

4.3.1.3 Comparative Delivery Time Gaps

The comparative time gaps make a direct comparison between the exact delivery time by all-road transport and the delivery time by intermodal transport. If intermodal transport can arrive inside a user defined²¹ time gap by means of the all-road delivery time, then the delivery time of intermodal transport will be considered equivalent. Earlier delivery by intermodal transport is always allowed. A time gap is a certain period of time, e.g. one hour. This takes into account the fact that the acceptance of a later delivery time is probably greater if it is only a slight difference from the delivery time of the road transport system. Figure 17 shows an example of where intermodal transport delivers within the comparative time gap and is thus considered equivalent to all-road transport.

²⁰ The difference by using the time overlap compared to just extending the time period is that all-road transport arriving inside the time overlap from a previous time period (e.g. at the X in Figure 16) makes the entire coming time period allowed for intermodal transport, which would not have been the case if the time windows had been extended. The time overlap is thus shared between the time periods.

²¹ The time gaps are set for each of the time windows used for the delivery time windows, i.e. the time window the all-road transport arrives in determines which comparative time gap to use. If only the comparative time gaps should be used, then the time windows should be shorter than the gaps used.

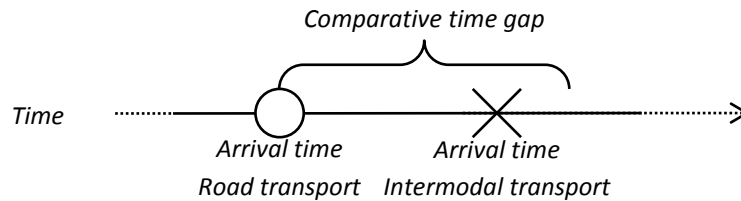

Figure 17 Comparative delivery time gaps

The comparative time gaps can also be used in combination with the delivery time windows to reduce the marginal effects when, for example, a shipment is disqualified from intermodal transport for arriving five minutes after the end of a long delivery time window, but is still only delivered slightly later than all-road transport. If both delivery time windows and comparative time gaps are used simultaneously, it is enough that one of them is satisfied in order for the delivery time to be considered equivalent to all-road transport.

4.3.1.4 Departure Time Windows

Similar modelling is also used for the departure times. The departure time for all-road transport is given by the input data, i.e. the time for the demand occurrence. However, it is unrealistic to assume that the shipper does not have any flexibility in adjusting the departure time, especially since the departure times set in the input data are most often expected to be based on average statistics²². Intermodal transport is dependent on meeting the train's departure times at the terminal, and since normally there only are a few departures per day, the departure time from the demand point becomes very important. The model must, therefore, be given some flexibility in order to adjust the departure time from the sending demand point to match the available train departures. Departure time windows and comparative departure time gaps, similar to the time windows and gaps used when comparing delivery times, will therefore be used. The methods can be used individually or simultaneously. The time windows and gaps used are the same as for the arrival calculations.

The intermodal transport departure times from the sending demand point can be adjusted inside a user defined departure time window. Later departure times for intermodal transport are always allowed²³. See Figure 18 where both intermodal transport and all-road transport have equivalent departure times.

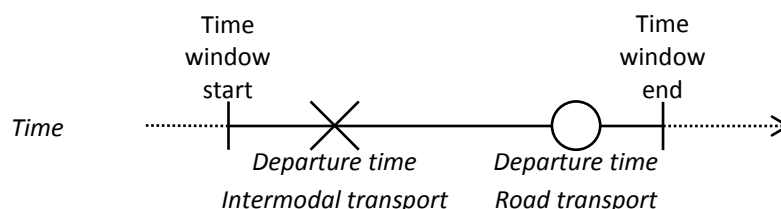

Figure 18 Departure time windows

²² Data availability makes this the most likely option. However, the model could also be used by a transport operator or shipper with detailed flow data.

²³ In reality, later departure times could always be arranged to match all-road departures simply by departing the same time as all-road transport and allowing the goods to wait at the terminal.

As with the delivery time windows, a shared overlap time period between two adjacent time windows can be used. The shared overlap is considered to belong to the time periods that leave the greatest time window for intermodal transport.

4.3.1.5 Comparative Departure Time Gaps

A comparative departure time gap allows intermodal transport to depart earlier than all-road transport as long as it is within the time gap. Later departure times for intermodal transport are always allowed. See Figure 19 where the model has determined that an earlier departure time for intermodal transport is more appropriate, e.g. to catch an early train at the terminal. The suggested departure time is within the allowed time gap. Thus, the suggested departure time is allowed.

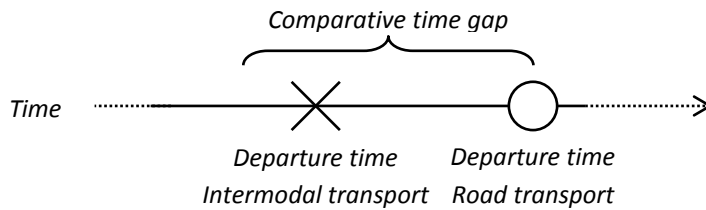

Figure 19 Comparative departure time gap

4.3.1.6 Operating window

Together, the time periods, time overlap and time gaps form an allowed time window for intermodal transport in which to operate, i.e. the time window between the earliest allowed departure time and latest allowed delivery time. Two examples of operating windows using only time periods and time gaps can be seen in Figure 20.

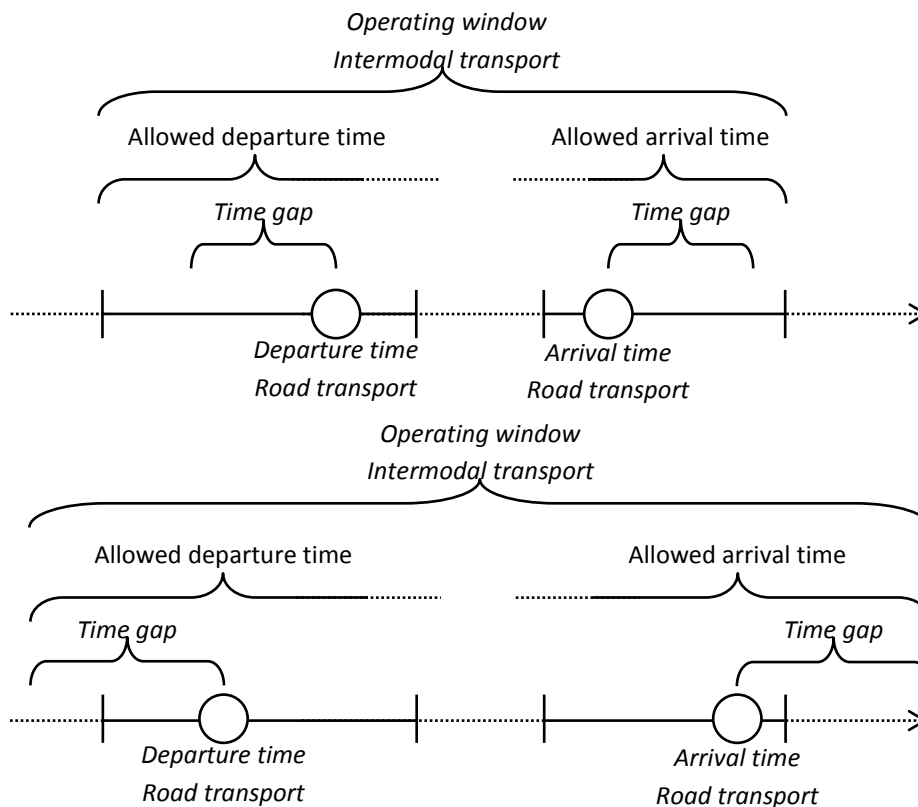

Figure 20 Examples of operating windows for intermodal transport

The figure shows both the time windows and the comparative time gaps. In the first example, the comparative time gaps are within the allowed time windows. The operating window thus follows the time windows, since they provide a more generous operating window. The time gaps will then not affect the operating window. In the second example, the comparative time gaps stretch outside the time windows. The time windows are then disregarded, and the operating window follows the comparative time gaps²⁴.

The time system in the model is implemented using a continuous time scale. Each demand occurrence and train departure can freely, and independently of each other, be set to any time. The time windows and time gaps can also be defined individually for each transport link and time. A decimal system is, for mathematical simplicity, used for all time measurements, e.g. 1 hour and 30 minutes are calculated as 1.5 hours. Note that the model itself does not use any running clock, continuous or discrete.

4.3.1.7 User Interface

The time periods are input in the Time Periods form. Each view shows one time period for one transport link. The bottom of the screen shows all time periods input for that transport link.

4.3.1.8 Constraints

Time is input as a non-negative decimal value²⁵. It is not recommended to use extremely large numbers to represent time (more than 15 significant digits). Due to how decimal numbers are handled in computers, see chapter 8, the accuracy will be reduced for larger numbers.

Origin and destination are input as an integer number between 1 and 65 535.

Each transport link must have at least one time period, and it must start at time 0²⁶. Note that very long time periods will increase model runtime and computer memory requirements, as the number of possible train departures that a demand occurrence can use will increase, i.e., more departures need to be checked for each demand occurrence.

When assigning the overlap in the time periods, remember to not set the departure time gap and overlap for the first time period at numbers so large that the time might be negative, e.g. if the demand departs starting at 1 and the time gap is set to 2, then the result would be time -1, which is not allowed. The early time gap and overlap from departure must be set to zero for the time period starting at 0, or the time will be negative.

4.3.2 Allowed Train Loops

The number of trains to be used and their departure time are also an important aspect of designing an intermodal transport system. The train time table can be input directly if it is known. See below. However, the HIT-model can also determine the time table to be used. To let the model freely and exactly decide all train departures and time tables is a very complicated problem, and is not necessary for strategic implications. It is satisfactory to determine roughly the best departure time for a train, rather than the exact second. This is particularly the case since the use of time periods

²⁴ Naturally, the selection between time windows or time gaps can be mixed, e.g. that time windows are used to set the allowed departure time and time gaps are used to set the allowed arrival time.

²⁵ It is possible to run the HIT-model with negative time numbering, but then the time dependant costs will become earnings during the negative time periods, i.e. a negative cost.

²⁶ It is possible to select any positive number as a starting time in the HIT-model, but zero is recommended.

and time gaps allows the departure and arrival time of the demand to be adjusted to match the train's departure time. Train departure times are, therefore, handled by giving the model a number of allowed train loops to choose from. A number of suggested train loops are input to the model and the model decides which of these loops are to be used and how long the train on each loop should be. By selecting an evenly distributed number of possible train loops, a satisfactory train system can be calculated. The model can also be set to allow several trains on the same train loop (a given number, a minimum number, a maximum number or an unlimited number), as an alternative way to model several train loops close to one another. This also reduces the model run time. It is not recommended to run the model with too many loops close together, as this level of detail is too high for a strategic purpose.

The allowed train loops are the possible train departures and train loops that the model can choose from. Each train departure is input with

- departure times
- train type
- number of trains allowed on the loop (a given number of trains, a minimum number of trains, a maximum number of trains or an unlimited number of trains)
- a train loop number

Departures with the same train loop number are considered to be performed by the same train and thus are kept together in the model. When the heuristics determine if a new train capacity should be added to a train loop, they consider the cost savings from the entire train loop (i.e. all departures performed by the train). Also, when a new capacity is added to a train, it is made available to all departures on the train loop. See the manual entitled Heuristics for a further description.

Train loop number, train types and number of trains are input as positive integers. Note that the HIT-model accepts any input time table, i.e. it does not check whether the train loops are feasible.

It is recommended that the train departures be kept together in closed train loops (from A to B to A to...) with the same number of rail cars in both directions, in order to avoid problems with unbalanced flows. If, for some reason, the model should need to be run without closed loops, this can be modelled by simply inputting each departure as a separate "train loop" in the input data. Unbalanced flows would otherwise result in an unrealistic accumulation of rail cars in one end of the flow and a shortage of rail cars in the other end. The cost of returning the rail cars must affect the intermodal transport system, as this is a direct effect of transferring goods to the intermodal transport system. These empty haulage costs are thus represented by using closed train loops, i.e. the same train length in both directions. The specialised intermodal transport rail cars also have a limited usage outside the intermodal transport system. This also simplifies the cost calculations for the rail transport and eliminates the need to consider shunting between trains. Train loops operating on several train routes, e.g. A to B to C to B to D, etc. can also be run in the model. However, train route optimisation can then naturally not be used, since the train routes affect each other.

When using closed train loops where the train capacity is made available to the entire train loop, it is necessary that both directions of the train route are given an equal representation in the input data

set²⁷. A higher cost saving in one direction would otherwise be over- or under-represented. A train should thus, if possible, run A to B as many times as it runs B to A, i.e. “close” the loop. This can also be achieved by running the model over an extended period of time so that the effects of unbalanced flows are negligible. This can be a preferable strategy if it is difficult to “close” all loops in a train system at the same time.

4.3.2.1 User Interface

The allowed train loops are input in the form Allowed Train Departures. The bottom of the screen shows all other input departures in the same train loop to the left and all input departures on the train route on the right.

4.3.2.2 Constraints

Train loop number, train types and number of trains must be an integer number between 0 and 65 535. Train loop numbers must be unique, even if they are on different train routes.

Time must not be a negative value.

If the train loop is short or the time windows are generous, it is possible that a demand occurrence, potentially, could be sent by two consecutive departures on the same train loop, i.e. both departures meets the time constraints. The HIT-model will only consider the first of these departures²⁸.

4.3.3 Allowed Lorries

It is also possible to restrict the types of lorries that can be used between two destinations. If, for example, it is known that a certain type of lorry is not used on a route, the HIT-model can be restricted from choosing that lorry type. This can also be used to model the ways that different types of cargo require different types of lorries²⁹.

This, also, makes it possible to ban a certain transport mode for a certain transport link by simply not allowing any lorries for that mode on the transport link. The model will, then, disregard the modal choice rules and assign the demand to the sole allowed transport mode. The necessary train capacity is automatically inserted, if the only allowed mode is intermodal transport³⁰). This gives a restricted optimization, where the remainder of the HIT-model operates according to the modal choice rules. This option can also be used in order to use the HIT-model as a calculation tool, where the costs and emissions of an already-known transport system are calculated. The input data is then designed to only contain the allowed lorries, according to an already known modal split. The option to use the HIT-model as a cost calculation tool is explained more in chapter 6.2

The allowed lorries can be defined individually for each transport link (A to B), transport mode and time period. The time periods can also be set freely for each transport link. Note that no comparative cost for all-road transport is calculated when a demand occurrence is forced to use intermodal

²⁷ Assume that direction A-B has a cost saving of 100 and direction B-A has a cost saving of 10. If A-B is run twice and B-A is run once, then the total cost saving for the loop is 210. If B-A is run twice and A-B is run once, then the total cost saving is 120.

²⁸ The cost saving from the demand occurrence would be counted double if this was allowed.

²⁹ Extra, parallel, transport links (A-B) are defined for the different types of cargo, with different allowed lorries. The demand is then divided between the links.

³⁰ Demand assigned to combined transport are sent with the first train to depart after the demand has arrived at the terminal. Alternative trains are not considered, since there are no all-road transport alternative to use to determine what trains are allowed.

transport (i.e. when no all-road lorry is allowed), since there are no all-road lorries allowed to calculate the comparative cost. This will affect the aggregated cost saving.

The allowed lorries are input as the lorry types that are allowed to be used between two demand points and the time window they are allowed. See chapter 4.3.1 for a description on the use of time periods. Data is input both for all-road lorries and intermodal transport lorries. The time period is input as the start of the period when these lorries are allowed. The time period (and allowed lorries) runs until a new time period start is input. E.g. if lorry type 1 is input as allowed from time period 10, this lorry type is then allowed until a new time period start is input for the same origin and destination. The time periods can thus be set individually for each transport link. For example, if lorry type 3 should be allowed between time 10 and 20, and lorry type 4 should be allowed between time 15 and 20, then lorry type 3 must first be input with time period start 10. After that lorry 4, it must be input with time period start 15. This starts a new time period, and the previously allowed lorry 3 is not allowed any more, and must be input again as allowed for time period start 15.

Note that the departure time of a demand occurrence can be adjusted in time; see chapter 4.3.1. The list of allowed lorries refers to the original departure time of the demand occurrence.

4.3.3.1 User Interface

The allowed lorries are input in the form Allowed Lorries. The bottom of the form shows all input allowed lorries for the current time period and transport link to the left, and all input allowed lorries for the transport link to the right.

4.3.3.2 Constraints

Origin and destination are input as an integer number between 1 and 65 535. Time is input as a decimal value. Note that at least one time period must be input for each transport link and mode³¹. The earliest time period must start at time 0. If the input value BOTH is used together with a specific lorry type number, then that type number must exist for both all-road lorries and intermodal lorries.

4.3.4 Control Parameters

Parameters are used to control the behaviour of the model. Five specific control parameters are used, in addition to the control possibilities made possible by varying the general input data as described above.

The *optimisation type parameter* selects whether business economic data should be used in the calculations or if social cost data should be used. Note that this only affects the data used in the heuristics process. Both types of data are always calculated in the model output.

The *system optimisation parameter* decides if the model should try to optimise the system according to each train route or according to the entire transport system, i.e. the entire system in the input dataset³². See the manual “Heuristics”.

The *maximum transfer or lowest cost parameter* decides whether the model should try to find the system with the lowest total cost or the system that transfers the most goods to intermodal

³¹ To allow all lorry types for the entire model run, just input all lorry types allowed at time period start 0, for each mode.

³² Note that this means that large cost savings in one part of the transport system will help fund unprofitable transports in other parts of the system, if a maximum transfer of goods is also selected.

transport without an increase in total system cost. When the lowest cost optimisation is selected, only demands that provide positive cost savings are met by intermodal transport³³. When trying to transfer as many goods as possible without an increase in total system costs, demands with negative cost savings can be met by intermodal transport, until the total cost savings for the system turn negative.

The *cost control parameter* allows intermodal transport to be a given percent more expensive, or demands that its cost be a given percent lower than that of all-road transport in order to be selected. This, thus, adjusts the modal choice. The parameter is input as a percentage comparison to the intermodal transport cost, e.g. 100% means that the parameter is not used, 110% means that intermodal transport is allowed to have a 10% higher cost, 90% means that it should only have 90% of the cost, etc.

The *market share parameter* adds a random disturbance to the modal choice. A given percent of the demand that has been assigned to intermodal transport is randomly reassigned to all-road transport³⁴. This can also be used for sensitivity analysis. Zero means that the parameter is ignored.

Apart from the specific control parameters described above, there are also a number of other different settings possible for the model, as described previously in this chapter. These can also be regarded as control parameters, e.g. time periods used, lorry types allowed, banning of a certain mode, number of demand points used, number of terminals, the use of common fixed costs, etc.

4.3.4.1 User interface

The control parameters are input in the form Control Parameters.

4.3.4.2 Constraints

Optimisation type, system optimisation and maximum transfer parameters are input as binary variables (either 0 or 1).

The cost control parameter is input as a positive decimal number. A value of 1 means 100%, i.e. the parameter is not used. A value of 1.1 means that intermodal transport is allowed to have a 10% higher cost.

The market share parameter is input as a decimal number between 0 and 1. The value 1 means 100%, i.e. everything is reassigned to all-road. 0 means 0% is reassigned to all-road, i.e. the parameter is not used. Values in-between, e.g. 0.5 means 50% is reassigned to the road, etc.

³³ Any transport in the intermodal transport system with a negative cost saving would only increase the transport system cost, irrespectively of on which train route it occurs. Note that the setting of the system optimisation parameter will then not affect the results, as the lowest cost system cannot be improved by cross subsidising. However, a slight difference might occur due to how shared fixed costs are handled. See the manual "Heuristics".

³⁴ Each time something is assigned to combined transport, a random generator returns a number which determines if it should be reassigned to all-road transport. No train capacity etc. is then added.

5 Output Data

The model output data consists of:

- intermodal transport demand
- road transport demand
- train loops
- aggregated data
- data file

The data is output for each individual demand occurrence, train departure and train loop. Information about the file formats used can be found in chapter 7.5. The same variable types and constraints are used in the output data, as in the input data. The output data is in the user interface shown in the Output data group and consists of three forms.

5.1 Summary data

The general summary data is output in short text file. This text file contains some general data on the model run. The intention is not that this file should be used for extensive analysis, but just for a quick overview of the last model run, and for technical information concerning the model run³⁵. The file contains:

- technical data of the model run
- runtime
- date and time
- control parameter settings
- summary data of the modal split
- weight transported in each mode
- number of trains
- train length
- number of lorries
- all aggregated cost for both business economic calculations and societal economic calculations.
- warnings if anything has affected the model heuristics, e.g. if demand occurrences have been forced to used a certain mode.

5.1.1 User interface

The summary file is shown in the Data file form.

5.2 Intermodal Transport Demand

The intermodal transport demand contains the demand occurrences, or parts of them, that have been assigned to intermodal transport. For each individual demand occurrence, the output contains:

- origin
- destination
- weight transported

³⁵ All data except technical data, runtime, date and time, control parameter settings and warnings can be found in other output files.

- original input time ready for transport (from the input data)
- calculated departure time
- calculated arrival time
- arrival time if the demand should have been sent by all-road transport
- train departure used
- loop used
- position on train
- transport time to terminal
- transport time from terminal
- transport time train
- lorry type used
- number of lorries used
- lorry type used if the demand should have been sent by all-road transport
- number of lorries used if the demand should have been sent by all-road transport
- environmental effects (CO₂, CO, SO₂, NO_x, PM, HC, energy consumption, monetary estimation)
- business economic and social costs divided into:
 - cost for the rail transport
 - terminal cost
 - cost in the road part of intermodal transport
 - cost if all-road transport would have been used
 - total cost
 - cost saving in the road transport system
 - total cost saving
- Serial- and loading number
- Reason for modal choice

The original input demand occurrences might have been split between several trains or both modes. If a demand occurrence has been split, this is shown by a variable (yes or no). The split parts of the original demand occurrence are output as separate demand occurrences. The original input demand and the other parts of the split demand can, if necessary, be identified by looking at the origin, destination and time originally ready for transport variables. Care must be taken when looking at the number of all-road transport lorries for the split demand occurrences, as that number might be misleading. See chapter 5.3

The model also outputs a number code to show the reason for the modal choice. If the reason for selecting intermodal transport was that the input data did not allow any all-road transport lorries for the demand occurrence, then code 7 is used. If the demand occurrence was transferred during the first step in the heuristics, i.e. the lowest cost system, then the code 0 is used, and if it was transferred during the second part, i.e. a maximum transfer of goods without a total cost increase, then code 10 is used. See chapter 5.3 for more codes.

It should be noted that the cost of inserting a new train capacity is assigned to the last demand occurrence in the group of demand occurrences that caused the train capacity to be inserted, when

searching for the lowest cost system. If the cost savings from several demand occurrences are needed to finance a new train capacity, the total cost of the train capacity is thus assigned to the last demand occurrence that caused the intermodal cost savings, in order to make it possible to insert the train capacity. This must be remembered when looking at the costs for individual demand occurrences. All demand occurrences are given a serial number in the order they have been assigned to intermodal transport. The model outputs a second serial number where demand occurrences, transferred together, are given the same number to facilitate the analysis³⁶. When searching for maximum weight transfer, each individual ITU is assigned its own cost for a new train capacity during the transport. If no ITU is loaded on a departure on a train loop, then the capacity cost for that departure is assigned to the first ITU to be loaded on the train loop, i.e. on the train departure at the earliest point in time on the loop.

Note that the common fixed cost of a terminal is output as a separate demand occurrence. As a result, it can be seen that the to destination, from destination, weight, and time factors, etc., are set to zero.

If a total systems optimisation has been selected, then a common train route number has been used for all train routes. This number is 00.

5.2.1 User interface

The demand sent by intermodal transport is shown in the form Sent by Intermodal Transport.

5.3 All-Road Transport Demand

The road transport demand contains the demand occurrences, or parts of them, that have been assigned to all-road transport. The output contains:

- origin
- destination
- weight transported
- original time ready for transport (from the input data)
- lorry type used
- number of lorries used
- lorry type used
- number of lorries used if the demand should have been sent by intermodal transport
- the variable costs if the demand should have been sent by intermodal transport³⁷
- environmental effects of the transport (CO₂, CO, SO₂, NO_x, PM, HC, energy consumption, monetary estimation)
- if the demand has been split
- business economic and social costs for the road transport.
- serial number
- reason for modal choice

³⁶ The first serial number is called *Demand number* in the output data. The second serial number is called *Loaded by breakpoint number*.

³⁷ The variable costs are the road haulage costs to and from the terminal, terminal handling and the cost to use the necessary rail car capacity on the train. The exception is if no combined transport lorries or trains departures are allowed for the demand. Then, naturally, no costs can be calculated.

The model also outputs the reason why the demand occurrence was not sent by intermodal transport. Each reason is coded by a number. Note that the reason “intermodal transport too expensive”, is actually divided into several sub-reasons to indicate where, during the model run, the cost constraints are violated. The reasons are:

- Same sending and receiving terminal (code 4)
- No trains allowed at all on the train route (user constraint) (code 13)
- No intermodal transport lorries allowed (user constraint) (code 5)
- Intermodal transport cannot meet time constraints (code 2)
- Intermodal transport too expensive, road transport costs alone violate the cost constraints (lowest cost optimisation only) (code 1)
- Intermodal transport too expensive, road transport + variable train costs violate the constraints (lowest cost optimisation only) (code 8)
- No more trains allowed to insert on any of the allowed departures (user constraint) (code 9)
- Market share parameter forced road (user constraint) (code 6)
- Intermodal transport too expensive, no trains were inserted on any of the allowed departures for the demand occurrence (code 12)
- Intermodal transport too expensive, the demand occurrence was inserted in the train departure waiting lists, trains existed on one or more of the allowed departures, but the demand occurrence was unable to fund any new train capacity (code 3)
- The demand was first assigned to intermodal transport but later reassigned to direct road transport since the fixed terminal costs were too high³⁸ (code 11)

It should be noted that the reasons are not necessarily mutually exclusive, e.g. a demand occurrence might violate both the delivery time constraint and the economic constraint. The reasons are prioritised in the order they are listed here, e.g. if the delivery time constraint is violated, then that is listed as the reason and the demand occurrence is not tested any further. See also the manual Heuristics. This must be considered when analysing the output reason. See chapter 5.2 for more codes.

The HIT-model does not allow individual lorries to be split; however, the focus is on the intermodal transport system. It is thus the intermodal system that determines whether or not a demand occurrence needs to be split and determines where the demand should be split, e.g. sending two lorries with the first train and one with the second train. If the loading capacity is different between all-road lorries and intermodal lorries, then the number of lorries might be different in the two modes. The split might then not be exact for the all-road lorries³⁹. This must be considered when

³⁸ I.e. the aggregated cost saving never became positive. See the manual Heuristics.

³⁹ Normally, the exact cost for each split part is calculated, but sometimes an approximation has to be made. Assume that intermodal transport consists of 2 lorries with loading capacity 15 each. Both are fully loaded, i.e. total 30 weight units. All-road transport consists of lorries with loading capacity 30, i.e. only one lorry is used. When splitting the demand occurrence, 15 weight units ends up in each part. This requires 1 all-road lorry in each part since integer lorries are used, thus a total of 2 all-road lorries, i.e. one new lorry. The heuristics is based around a comparison between all-road transport and intermodal transport. This does not allow for the cost for all-road transport to change during the model run. Therefore, the original all-road cost is split proportionally between the two parts and a new lorry is added without adding new cost.

analyzing the output data. All demand occurrences are also given a serial number in the order they have been assigned to direct road transport.

5.3.1 User interface

The demand sent by all-road transport is shown in the Sent by All-Road Transport form.

5.4 Train System Data

The train system selected is output as:

- which of the available train loops to use
- number of trains on each train loop
- total length of rail cars on each train
- business economic cost
- social economic cost
- environmental effect (CO₂, CO, SO₂, NO_x, PM, HC, energy consumption, monetary estimation)
- total goods weight on train.

The same data is also output for each individual train departure, including the available capacity on each departure.

If a total systems optimisation has been selected, then a common train route number has been used for all trains routes. This number is 00.

5.4.1 User interface

The train departures are shown in the form Train Departures.

6 Analyses and the HIT-model as a calculation model

The HIT-model and its user interface can be used with numbers and analyses, and also as a calculation model for a full or partial given transport system.

6.1 Analyses

Microsoft Access is a very powerful database to analyse the output data. Some examples of analyses can be found in the Navigation pane to the left of the screen under *Analyses*. These analyses are prepared in user friendly forms cover the most basic analysis of the data. Further analyses are made available by selecting *Object type* in the top part, labeled *Navigate to category*, of the Navigation pane. Then select *Query* in the bottom half of the Navigation pane. This accesses a large number of queries that were prepared to analyse the database. The name of the query explains the purpose of the query⁴⁰. These queries are displayed as Microsoft Access queries and not as forms. Consult the help files or any book on Microsoft Access for information on how to use queries. A user can naturally also create his or her own queries.

6.2 The HIT-model as a calculation model

The HIT-model can also be used as a calculation model to calculate the costs and effects of a given transport system. The model will then not use the heuristic functions, but only calculate a given system. To use the HIT-model as a calculation model, all input data must be constrained to allow only one possible method of transport for each demand occurrence. This is done by using the input data for allowed lorry types. By allowing only lorry types for one transport mode⁴¹ at a given transport link and time, the demand occurrence is forced to use that transport mode.

Different modal choices between separate demand occurrences on the same transport link are modelled either by putting the demand in different time periods or by using parallel demand points and transport links, i.e. introducing two separate points representing the same geographical location and assigning the different demand occurrences to them. They can then be treated as two different flows with separate settings in the model. Similarly, different train departures for intermodal transport are selected by using time periods that only allow for one train departure. To use the HIT-model as a non-optimising, calculation model, see chapter 4.3.2 and 4.3.3.

6.2.1 Mixing calculations and heuristics

The calculation of a given system and the heuristic functions can be mixed freely in the same model run. This is simply done by constraining the modal options (i.e. the allowed lorries) on the given parts of the system, and leaving the remaining parts open. The HIT-model will automatically use the heuristic functions if there are no constraints⁴². It is thus possible to use the HIT-model as a calculation model for the parts of a transport system that are known, and in the same model run, use the heuristic functions for the parts of the transport system that need to be optimized, given the known system.

⁴⁰ CT in the query name is an abbreviation for combined transport, i.e. intermodal transport.

⁴¹ Note that HIT-model separates between lorries used in intermodal transport and lorries used in all-road transport.

⁴² Actually, the HIT-model always uses the heuristics, but when using a given system, the heuristics is constrained to only give one possible option.

6.2.2 GIS visualisation tool

The output data from the HIT-model can also be analysed in a GIS visualisation tool in the ArcGIS Desktop. A tool has been developed that reads the HIT output data and displays the flows, costs, emissions etc. on a map. Being able to geographically visualise the data simplifies the data analyses, since all transport data can be seen as a geographical connection. The GIS visualisation tool is described in the report *Visualizing Transport Flows, A GIS-based approach* by Erik Eldér and Anders Larsson.

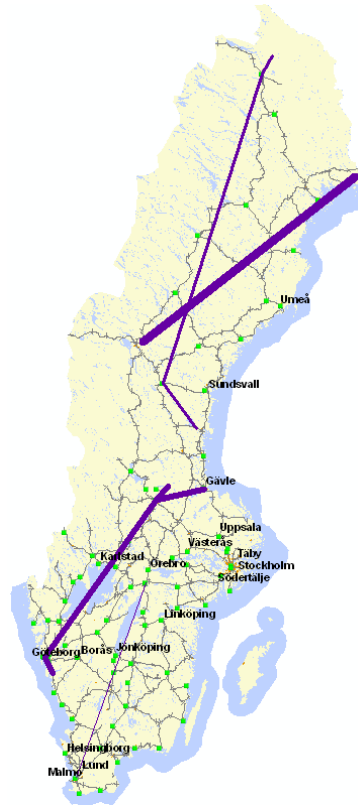

Figure 21 Flows from the HIT-model displayed on a map

7 File formats

Data is transferred to and from the calculation model by using text files. This chapter shows the file format used, i.e. how the data is formatted in the text files. This can be used if the input or output data needs to be handled by another program. Each text file consists of a number of records with one record per line. Each record consists of a number of fields separated by space. The file format uses a dot (.) as decimal point, unlike the Swedish standard, which uses a comma (,). Numbers can also be input using scientific notation, e.g. 5.89E-03.

The input files do not have to be sorted in any way, e.g. time periods do not have to be in chronological order, unless otherwise is stated in this chapter.

The data files can be created and read by the HIT-model user interface or any other program following the file formats in this chapter.

7.1 Input data

The data in this chapter is required to be input into the calculation model. For further description of the data, see chapter 0.

7.2 Transport network and demand

7.2.1 Transport Demand

The demand is input into the model in the file DEMAND.TXT. The file is formatted with one demand occurrence at each line, separated by a space. The order of each line is

- from origin
- to destination
- time
- demand to transport

For example, a demand of 14 at time 12.5, from destination 1275 to 180, is input as: 1275 180 12.5 14

An input file example:

```
1275 180 12.5 14
```

```
2409 180 18 25
```

```
1081 1810 11 38
```

```
1981 160 12.3 34
```

```
191 1980 13.71 14
```

```
1495 152 12.8 207
```

7.2.2 Road Distances

Road distances are input in the file ROADDIST.TXT. The file is formatted with one distance at each line separated by space. The order on each line is:

- from location
- to location
- distance

For example, the distance of 145 from location 180 to location 234 is input as: 180 234 145

An input file example:

```
180 234 145
115 2303 891
10014 2031 573
2039 2409 1100
180 120 350
120 180 382
```

7.2.3 Rail Distance

Rail distances are input in the file RAILDIST.TXT. The file is formatted with one distance at each line separated by space. The order on each line is:

- From location
- To location
- distance

For example, the distance of 253 from location 1170 to location 1820 is input as: 1170 1820 253

An input file example:

```
1170 1820 253
1115 303 921
2104 131 303
39 3091 1230
1565 2384 152
2384 1565 161
```

7.2.4 Terminal Areas

The terminal area is input in the file TERMAREA.TXT as the number of the demand point, followed by the number of the terminal it is assigned to, separated by space. To assign demand point 180 to terminal 10003 is input as: 180 10003

A sample input file would look like this:

```
180 10003
1981 10011
61 10012
234 10008
131 10001
2029 10001
```

7.3 Cost and Environment

7.3.1 All-Road Lorry Types

The all-road lorry types are input in the file LORRIES.TXT in the order⁴³:

- lorry type number
- loading capacity
- business economic cost per distance unit
- business economic cost per time unit
- societal economic cost per distance unit
- societal economic cost per time unit
- CO₂ emission per distance unit
- CO emission per distance unit
- NO_x emission per distance unit
- SO₂ emission per distance unit
- HC emission per distance unit
- PM emission per distance unit
- energy consumption per distance unit
- monetary estimation of pollution per distance unit
- lorry speed

One lorry type is input on each line. Assume we have lorry type 1 with the following characteristics: loading capacity 25, business economic cost per distance 10, business economic cost per time 1, societal economic cost per distance is 11 and per time is 2, CO₂ 100, CO 101, NO_x 102, SO₂ 103, HC 104, PM 105, energy consumption 999, monetary estimation of pollution 30 and lorry speed 80. This is then input as: 1 25 10 1 11 2 100 101 102 103 104 105 999 30 80

An input file example:

```
1 25 10 1 11 2 100 101 102 103 104 105 999 30 80
2 40 4.17 321 6.34 321 1200 1.10 7.80 1.6e-03 0.64 0.13 16 2.33 80
3 25 2.97 302 4.85 302 890 0.81 5.60 1.1e-03 0.45 0.09 12 1.71 80
4 26 2.97 302 4.85 302 890 0.81 5.60 1.1e-03 0.45 0.09 12 1.71 80
```

7.3.2 Intermodal Transport Lorry Types

The intermodal transport lorry types are input in the file CT_LORRY.TXT and follows the same pattern as for all-road transport lorries, with the addition of the length required on a rail car. This is input at the end of the row. The lorry type 1 described in chapter 7.3.1 requires 1710 length units on a railcar would thus be input as: 1 25 10 1 11 2 100 101 102 103 104 105 999 30 80 1710

An input file example:

```
1 25 10 1 11 2 100 101 102 103 104 105 999 30 80 1710
2 37 4.17 321 6.34 321 1200. 1.10 7.80 1.6e-03 0.64 0.13 16.00 2.33 80 2565
3 24 2.97 302 4.85 302 890 0.81 5.60 1.1e-03 0.45 0.09 12 1.71 80 1710
4 25 2.97 302 4.85 302 890 0.81 5.60 1.1e-03 0.45 0.09 12 1.71 80 1710
```

⁴³ Note that all emission variables are distance dependant and could also be used for other distance dependant emissions or costs than the emissions named in the variable name.

7.3.3 Train Types

The types of trains are input in the file TRAINS.TXT. The file order⁴³ is:

- train type
- loading capacity in length units
- train speed
- new train business economic cost
 - per distance unit
 - per time unit
- new train societal economic cost
 - per distance unit
 - per time unit
- new rail car length unit business economic cost
 - per distance unit
 - per time unit
- new rail car length unit societal economic cost
 - per distance unit
 - per time unit
- using rail car length unit business economic cost
 - per distance unit
 - per time unit
- using rail car length unit societal economic cost
 - per distance unit
 - per time unit
- new train
 - CO2 emission
 - CO emission
 - NOx emission
 - SO2 emission
 - HC emission
 - PM emission
 - energy consumption
 - monetary estimation of pollution
- new rail car length unit
 - CO2 emission
 - CO emission
 - NOx emission
 - unit SO2 emission
 - HC emission
 - PM emission
 - energy consumption
 - monetary estimation of pollution
- using rail car length unit
 - CO2 emission
 - CO emission

- NOx emission
- SO2 emission
- HC emission
- PM emission
- energy consumption
- monetary estimation of pollution.

One train type per line.

An input file example (the example is one line):

```
1 615600 70 4.55 900 4.85 900 1.52437e-04 0.01 1.63e-04 0.01 1.92523e-04 0 2.1e-04 0 49.25 0.01
0.12 0.11 1.025445e-03 5.887589e-03 5.83 0.08 6.3437797e-03 2.0812e-06 1.61006e-05
1.52226e-05 1.321e-07 7.583e-07 7.509474e-04 1.103e-05 0.01 3.9472e-06 3.05355e-05
2.88705e-05 2.505e-07 1.4382e-06 1.4242105e-03 2.092e-05
```

7.3.4 Terminal Handling Data

Terminal handling data is input in the file TERMINAL.TXT. The file order⁴³ is:

- terminal number
- intermodal transport lorry type number
- business economic cost per handling
- societal economic cost per handling
- CO2 emission
- CO emission
- NOx emission
- SO2 emission
- HC emission
- PM emission
- energy consumption
- monetary estimation of pollution

Each line represents one type of lorry that can be handled at the terminal. A lorry type 3 at terminal 10003 with a business economic cost of 460, social economic cost of 470, CO2 emission of 11787, CO emission of 104, NOx emission of 222, SO2 emission of 0, HC emission of 28, PM emission of 11, energy consumption of 154 and monetary estimation of 9 is input as 10003 3 460 470 11787 104 222 0 28 11 154 9.

An input file example:

```
10003 1 460 470 11787 104 222 0 28 11 154 9
10003 3 460 470 11787 104 222 0 28 11 154 9
10003 2 230 235 5894 52 111 0 14 5 77 5
10004 2 230 235 5894 52 111 0 14 5 77 5
10011 2 230 235 5894 52 111 0 14 5 77 5
10010 1 460 470 11787 104 222 0 28 11 154 9
```

7.3.5 Common Fixed Costs

Common fixed costs are input in the file FIXTERM.TXT. The file order⁴³ is:

- train route number
- business economic cost
- societal economic cost
- CO2 emission
- CO emission
- NOx emission
- SO2 emission
- HC emission
- PM emission
- energy consumption
- monetary estimation of pollution

Train route 1000410013 with business economic cost 139093.80, social economic cost 139093.80, CO2 emission 123, CO emission 423, NOx emission 443, SO2 emission 453, HC emission 10, PM emission 112, energy consumption 121 and monetary estimation of pollution 2356 is input as 1000410013 139093.80 139093.80 123 423 443 453 10 112 121 2356.

An input file example:

```
1000410013 139093.80 139093.80 123 423 443 453 10 112 121 2356.
1000510009 139093.80 139093.80 230 343 734 234 12 134 15 1355
1000210004 139093.80 139093.80 213 134 567 745 556 578 0 677
1000410007 115902.40 119452.10 633 676 333 876 4565 7567 234 16535
```

7.4 Settings and Transport Framework

7.4.1 Time periods

Time periods are input in the file TIMEPERI.TXT. A time period is assumed to run until a new time period is input for the same transport link. The file order is:

- from origin
- to destination
- time period start
- departure time period overlap
- arrival time period overlap
- departure comparative time gap
- arrival comparative time gap

A time period starting at time 5 between origin 1480 and destination 6006, with a departure time overlap of 1.5, arrival time overlap of 2, departure comparative time gap of 2.2 and arrival comparative time gap of 1 is input as 1480 9006 5 1.5 2 2.2 1. To end the time period at, for example, time 10, a new time period starting at 10 must be defined.

An input file example:

```
1480 9006 0 0 2 0 1
1480 9006 5 1.5 2 2.2 1
1480 9006 10 1.5 2 2.2 1
1231 213 0 0 0.2 0 1
1231 213 7 1 0.2 3 1
```

7.4.2 Allowed Train Loops

The allowed train loops, i.e. the possible train departures to choose from, are input in two files, TRAJNTAB.TXT and MAXLOOP.TXT. TRAJNTAB.TXT contains each allowed train departure. The file order is:

- from origin, to destination
- departure time
- train type
- train loop number

A train departure from location 10011 to 10014 at the 12 with train type 1 and on train loop 94 is input as 10011 10014 12.00 1 94.

An input file example:

```
10011 10014 12.00 1 94
10002 10009 18.00 1 236
10006 10011 22.00 2 121
10010 10012 12.00 1 141
10012 10010 27.00 1 141
```

MAXLOOP.TXT contains any constraints on the number of trains allowed on the train loop. The file order is:

- train loop number
- max number of trains
- type of constraint

The possible constraints are that the number input is the exact number of trains on the train loop (i.e. the trains are already input on the train loop and no more trains can be added), the maximum number of trains (i.e. the HIT-model starts with 0 trains on the train loop and can add up to this number of trains) or the minimum number of trains (i.e. the HIT-model starts with this number of trains already inserted, and more trains can be added). The type of constraint is represented by M for a maximum number of trains, L for the least (minimum) number of trains and E for the exact number of trains⁴⁴. Note that if no data is input for a train loop, it is assumed that the numbers of trains are unlimited, i.e. no constraint applies. Data is thus only input for train loops with a constraint. For example, a maximum of 10 trains on train loop one is input as 1 10 M.

⁴⁴ The HIT-model only reads the first character in the word. It is possible to input the full words MAXIMUM, LEAST and EXACT to improve readability. This is done in the Microsoft Access user interface.

An input file example:

```
1 10 M
2 8 E
10 4 L
94 3 E
```

7.4.3 Allowed Lorries

Allowed lorries are input in the file ALLOWLOR.TXT. The file order is:

- from origin
- to destination
- time period start
- transport mode
- lorry type number

Transport mode is input as C for intermodal (combined) transport, R for road or B for both. The lorry type number is input as the type number used when defining the lorries (see chapter 7.3.1) or A is input when all lorry types are allowed, or N when no lorry types are allowed for that mode⁴⁵.

Allowing no lorry types for a mode is the same thing as forcing the demand occurrences to use the other mode. One input line is used for each lorry type, e.g. if both lorry type 1 and 2, but not 3, are allowed for a certain time period, then two input lines are used, one for lorry type 1 and one for lorry type 2. Note that the file must be sorted according to the time periods with the lowest first⁴⁶. This sorting is done automatically if the user interface in Microsoft Access is used.

The allowed lorries are reset for each new time period. Thus, if lorry type 3 should be allowed between time 10 and 20, and lorry type 4 should be allowed between time 15 and 20. Then, lorry type 3 must first be input with a time period start 10. After this, lorry 4 must be input with time period start 15. The previously allowed lorry 3 is then not allowed after time 15 (since a new time periods starts) and must be input again as allowed with time period start 15.

To allow all lorry types in intermodal transport between origin 9000 and destination 2482 starting at time period 0, and then only allow lorry types 2 from time period 10 and allowing both type 2 and 3 from time period 20 and onwards, four lines are input:

```
9000 2482 0.00 C A
9000 2482 10.00 C 2
9000 2482 20.00 C 3
9000 2482 20.00 C 2
```

A sample input file for this operation:

```
9000 2482 0.00 C A
9000 180 0.00 C 4
```

⁴⁵ The HIT-model only reads the first character in the word. It is possible to input the full words COMBINED, ROAD, BOTH, ALL and NONE to improve readability. This is done in the Microsoft Access user interface.

⁴⁶ The HIT-model copies some data from previous time periods when reading the file.

9000 2281 45.00 R N
1290 9001 242.00 C A

7.4.4 Control Parameters

The control parameters are input in the file PARAMETE.TXT. The file consists of one single line with all parameters. The line order is optimisation type (1 (true) = business, 0 (false) = societal), system optimisation (1 (true) = entire system, 0 (false) = each train route), maximum transfer (1 (true) = maximum transfer, 0 (false) = lowest cost), cost control and market share. A business cost optimisation for the entire system, searching for the lowest cost system while requiring intermodal transport to have 10% lower cost, but no random disturbance is input as: 1 1 0 0.90 0

An example of an input file:

1 1 0 0.90 0

7.5 Output Data

The output data files are located in the subdirectory OUTPUT to the directory where the file *HIT-model.exe* is stored. Normally, this is C:/HIT-MODEL/OUTPUT. A further description of the data in the output files is available in chapter 5.

7.5.1 Summary data

Summary data is output in the file DATA.TXT. The file is intended to be read as a text document and is not formatted to automatically be read by a computer application. The file contains technical data from the model run, run time, date and time, control parameter settings and summary data of the modal split, weight transported in each mode, number of trains, train length, number of lorries and all aggregated costs for both business economic calculations and societal economic calculations. The file also contains warnings if anything has affected the model heuristics, e.g. if demand occurrences have been forced to use a certain mode.

An example of the output file⁴⁷:

```
*****
*   Heuristic Intermodal Transport Model, HIT-model   *
*****
```

Jonas Flodén
Department of Business Administration
School of Economics and Commercial Law at Göteborg University
P.O. Box 610
SE 405 30 Göteborg
Sweden

Phone: +46 31 786 51 31
Fax: +46 31 786 52 44
E-mail: jonas.floden@handels.gu.se
E-mail: jonas.floden@jonasfloden.se
<http://www.handels.gu.se/fek/logistikgruppen/>

<http://www.handels.gu.se/>

<http://www.gu.se/>

⁴⁷ The output data is imaginary.

Year 2003-2008

Copyright Jonas Floden

The model may not be used without written permission from Jonas Floden

Program runtime units: 1298173

Program runtime seconds: 1298

Program runtime: 0 hours, 21 minutes, 38 seconds

Local time is: Mon Feb 18 11:18:03 2008

Control parameters

Business economic calculation selected

Optimisation for each train route (A-B-A) selected

(Note that the aggregated costs below are for the entire system and not for each train route.

This means that the aggregated values might be negative.)

Optimisation for lowest system cost selected

Cost control parameter set to: 1

(This allows intermodal transport to have a cost 0% higher(+)/lower(-) than all road transport.)

Market share control parameter is set to: 0

(This means that 0% of the demand that the model

wanted to send by intermodal transport has been sent by road transport instead)

Summary data

Total number of tons transported: 364650

Total number of tons in the intermodal transport system: 145860

Total number of tons in the all road transport system: 218790

Total number of trains used: 14

Total train length in the system (summary of all trains): 54000

Total number of direct road lorries used: 8260

Total number of intermodal transport lorries used: 6251

Total number of demand instances: 495

Total number of demand instances in the all road transport system: 310

Total number of demand instances in the intermodal transport system: -215

Business data

Total business cost for the entire transport system: 2.16301e+007

Total business cost for the direct road transport system: 1.15394e+007

Total business cost for the road transport system (incl. intermodal road): 1.3604e+007

Total business cost for the rail transport system: 8.02615e+006

Total business cost for the intermodal transport system: 1.00908e+007

Total business cost saving for the entire transport system: 7.86428e+006

Total business cost saving in the road transport system (incl. intermodal road): 1.58904e+007

Total business cost intermodal transport road transport part: 2.06463e+006

Total business cost if everything had been sent by all road transport: 2.94944e+007

Societal data

Total societal cost for the entire transport system: 2.56258e+007

Total societal cost for the direct road transport system: 1.47023e+007

Total societal cost for the road transport system (incl. intermodal road): 1.73399e+007

Total societal cost for the rail transport system: 8.2859e+006

Total societal cost for the intermodal transport system: 1.09234e+007

Total societal cost saving for the entire transport system: 1.19558e+007

Total societal cost saving in the road transport system (incl. intermodal road): 2.02417e+007

Total societal cost intermodal transport road transport part: 2.63754e+006
 Total societal cost if everything had been sent by all road transport: 3.75816e+007

End of file

7.5.2 Intermodal Transport Demand

The demand sent by intermodal (combined) transport is output in the file COMBINED.TXT. The first line of the file contains the variable names. Each line represents one demand occurrence, or part of a demand occurrence if the demand occurrence has been split. The file order is:

- From origin
- To destination
- Weight
- Time
- From terminal
- To terminal
- Train route
- Calculated arrival time
- Calculated departure time
- Train loop number
- Train departure time
- Position on train
- Intermodal lorry type number
- Road lorry type number
- No of intermodal lorries
- No of road lorries
- Business cost
 - intermodal road
 - rail
 - total intermodal
 - road
 - cost saving road system
 - total cost saving
- Societal cost
 - intermodal road
 - rail
 - total intermodal
 - road
 - cost saving road system
 - total cost saving
- Terminal
 - business cost
 - societal cost
- Transport time

- to terminal
- from terminal
- rail
- road
- Split class
- Demand serial number
- CO2 emission
- CO emission
- SO2 emission
- NOx emission
- PM emission
- HC emission
- Energy consumption
- Monetary estimation of pollution
- Reason for mode
- Loaded by breakpoint number

An example of the output file. The example is two lines. The first line is the variable names, and only occurs once in the output file as the first line:

```
"From" "To" "Weight" "Time" "From terminal" "To terminal" "Train route" "Calculated arrival time"
"Calculated departure time" "Train loop number" "Train departure time" "Position on train" "CT lorry
type number" "Road lorry type number" "No of CT lorries" "No of road lorries" "Business cost CT
road" "Business cost rail" "Business cost total CT" "Business cost road" "Business cost saving road
system" "Business cost total cost saving" "Societal cost CT road" "Societal cost rail" "Societal cost
total CT" "Societal cost road" "Societal cost saving road system" "Societal cost total cost saving"
"Terminal business cost" "Terminal societal cost" "Transport time to terminal" "Transport time from
terminal" "Transport time rail" "Transport time road" "Split class" "Demand number" "CO2 emission"
"CO emission" "SO2 emission" "NOx emission" "PM emission" "HC emission" "Energy consumption"
"Monetary estimation of pollution" "Reason for mode" "Loaded by breakpoint number"
2081 9000 730 128 10001 10003 1000110003 134.457 128 1315 128 0 4 4 29 29 0 17655.3 17655.3
85870.6 85870.6 68215.3 0 18337.1 18337.1 109805 109805 91467.8 13340 13630 0 0 6.45714
5.4875 0 36 235935 192.475 647.123 906.443 42.2368 33.6149 32077.2 478.915 0 96
```

7.5.3 Road Transport Demand

The demand sent by all-road transport is output in the file ROAD.TXT. The first line of the file contains the variable names. Each line represents one demand occurrence, or part of demand occurrence if the demand occurrence has been split. The file order is:

- From
- To
- Weight
- Time
- From terminal
- To terminal
- Train route

- Calculated arrival time
- Calculated departure time
- Intermodal lorry type number
- Road lorry type number
- No of intermodal lorries
- No of road lorries
- Business cost
 - intermodal road
 - rail
 - total intermodal
 - road
 - cost saving road system
 - total cost saving
- Societal cost
 - intermodal road
 - rail
 - total intermodal
 - road
 - cost saving road system
 - total cost saving
- Terminal
 - business cost
 - societal cost
- Transport time
 - to terminal
 - from terminal
 - rail
 - road
- Split class
- Demand number
- CO2 emission
- CO emission
- SO2 emission
- NOx emission
- PM emission
- HC emission
- Energy consumption
- Monetary estimation of pollution
- Reason for mode

An example of the output file. The example is two lines. The first line is the variable names, and only occurs once in the output file as the first line:

```
"From" "To" "Weight" "Time" "From terminal" "To terminal" "Train route" "Calculated arrival time"
"Calculated departure time" "CT lorry type number" "Road lorry type number" "No of CT lorries" "No
of road lorries" "Business cost CT road" "Business cost rail" "Business cost total CT" "Business cost
```

road" "Business cost saving road system" "Business cost total cost saving" "Societal cost CT road"
 "Societal cost rail" "Societal cost total CT" "Societal cost road" "Societal cost saving road system"
 "Societal cost total cost saving" "Terminal business cost" "Terminal societal cost" "Transport time to
 terminal" "Transport time from terminal" "Transport time rail" "Transport time road" "Split class"
 "Demand number" "CO2 emission" "CO emission" "SO2 emission" "NOx emission" "PM emission"
 "HC emission" "Energy consumption" "Monetary estimation of pollution" "Reason for mode"
 1081 180 38 12 10014 10010 00 18.075 12 2 1 2 1 1416.45 0 1416.45 3976.69 0 0 1811.25 0 1811.25
 5031.31 0 0 920 940 1.3125 0 0 6.075 0 1 583200 534.6 0.7776 3790.8 63.18 311.04 7776 1132.38 2

7.5.4 Train System Data

Data concerning the train system is output in two files. The file TRAINDEP.TXT contains data for each train departure and the file TRAINLOP.TXT contains data for each train loop.

TRAINDEP.TXT has one line for each train departure. The first line of the file contains the variable names. The file order is:

- Train loop number
- From origin
- To destination
- Time
- Length of train
- Number of trains
- Train type
- Train route
- Business cost
- Societal cost
- CO2 emission
- CO emission
- SO2 emission
- NOx emission
- PM emission
- HC emission
- Energy consumption
- Monetary estimation of pollution
- Available capacity on departure
- Weight on departure.

An example of the output file. The example is two lines. The first line is the variable names and only occurs once in the output file as the first line:

"Train loop number" "From" "To" "Time" "Length of rail cars" "Number of train" "Train type" "Train
 route" "Business cost" "Societal cost" "CO2 emission" "CO emission" "SO2 emission" "NOx emission"
 "PM emission" "HC emission" "Energy consumption" "Monetary estimation of pollution" "Available
 capacity on departure" "Weight on departure"
 1313 10003 10001 8 58140 1 1 1000110003 18381 19044.1 331961 115.654 913.98 862.579 7.5169
 43.1536 42734.3 625.156 26505 387

TRAINLOP.TXT has one line for each train loop. The first line of the file contains the variable names. The file order is:

- Train loop number
- From origin
- To destination
- Length of train
- Number of trains
- Train type
- Train route
- Business economic cost
- Societal economic cost
- CO2 emission
- CO emission
- SO2 emission
- NOx emission
- PM emission
- HC emission
- Energy consumption
- Monetary estimation of pollution
- Weight on train loop.

An example of the output file. The example is two lines. The first line is the variable names and only occurs once in the output file as the first line:

```
"Train loop number" "From" "To" "Length of rail cars" "Number of train" "Train type" "Train route"  
"Business cost" "Societal cost" "CO2 emission" "CO emission" "SO2 emission" "NOx emission" "PM  
emission" "HC emission" "Energy consumption" "Monetary estimation of pollution" "Weight on train  
loop"  
1313 10001 10003 58140 1 1 1000110003 781371 812082 1.56745e+007 5571.91 43875.7 41420.7  
360.697 2070.74 2.05062e+006 30018.8 23980
```

8 List of variables and constraints

This chapter contains a summary of the constraints on variable sizes in the HIT-model. The name of the variable type in Microsoft Visual Studio.NET 2003 C++ is also given. Note that the constraints can be changed by recompiling the source code using new variable types. See chapter 1.3.1. The maximum and minimum value shown here are the allowed ranges in the HIT-model, which might be less than the actual storage capacity in C++.

Decimal numbers are not always stored with the same number of decimals. Instead, the size of the storage area in the computer memory is (to simplify a bit) defined as a number of digits, and the number of decimals used is determined by the available space. Thus, if a large value is stored, the number of decimals used (i.e. the accuracy) is reduced. E.g. 10.2 uses the same storage capacity as 1.25. The largest value that can be stored is normally very large, but may yield reduced accuracy⁴⁸.

Note that when using the user interface in Microsoft Access, the largest number that can be stored by Access is 2 147 483 647, i.e. an unsigned int variable cannot be fully utilized. See chapter 2.2.1.

Name of data	Variable type	Data type	Minimum value	Maximum value	Notes
Demand locations	Short unsigned int	Positive integer	1	65 535	The value 0 is reserved for internal model use. From 0 to 0 stores the fixed costs of a train route.
Terminal locations	Short unsigned int	Positive integer	1	21 474	Constrained by that the location numbers are combined to create the train route number
Time	Double	Decimal number	0	15 digits (1.7e + 308)	Time is input using a decimal system, e.g. half past ten is input as 10.5 (if hours are used). It is not recommended to use more than 15 significant digits, since the accuracy will be reduced for larger numbers.
Demand	Unsigned int	Positive integer	0	4 294 967 295	Demand 0 has no meaning and should be avoided.
Distances	Unsigned int	Positive integer	0	4 294 967 295	Distance 0 can be used.
Costs	Double	Decimal number		15 digits (1.7e +/- 308)	Accuracy will be reduced after 15

⁴⁸ A large value would be stored as, for example, $1.7 * 10^{308}$

Emissions	Double	Decimal number	15 digits (1.7e +/- 308)		significant digits. Accuracy will be reduced after 15 significant digits.
Speed	Unsigned short int	Positive integer	1	65 535	Speed 0 will cause division by zero error.
Loading capacity	Unsigned int	Positive integer	1	4 294 967 295	Capacity 0 will cause division by zero error.
Vehicle and train type number	Unsigned short int	Positive integer	0	65 535	Three separate number series are used for all-road lorries, intermodal transport lorries and trains.
Train length and length required on a rail car	Unsigned int	Positive integer	1	4 294 967 295	Length 0 will cause division by zero error.
Train route	Int	Integer	-2 147 483 648	+2 147 483 647	The train route number must follow the given format. See chapter 4.2.4.
Train loop	Unsigned short int	Positive integer	0	65 535	
Number of trains and lorries	Unsigned short int	Positive integer	0	65 535	The summary variables are unsigned int, e.g. total number of lorries..
Control parameters type, system and transfer	Bool	Binary	0 or 1		1 = true, 0 = false
Cost control parameter	Double	Decimal number	0	15 digits (1.7e + 308)	
Market share parameter	Float	Decimal number	0	1	Maximum capacity 7 digits (3.4e + 38)

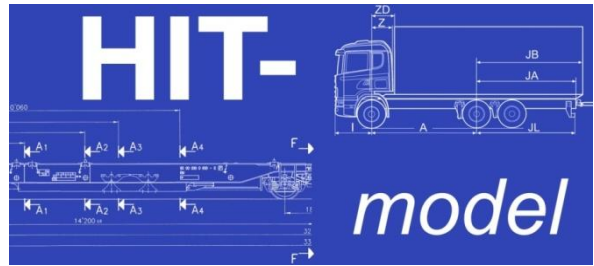

Suggested input data

The Heuristics Intermodal Transport Model

HIT-Model

Jonas Flodén

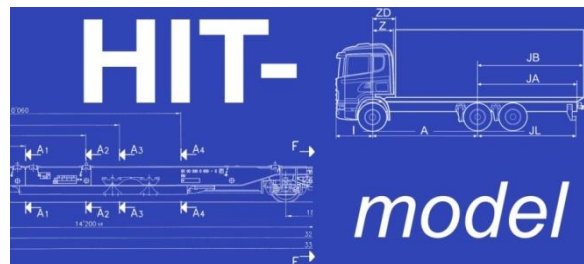

Jonas Flodén
Department of Business Administration
School of Business, Economics and Law
University of Gothenburg
P.O. Box 610
SE 405 30 Göteborg
Sweden

E-mail: jonas.floden@handels.gu.se
URL: <http://www.handels.gu.se/fek/logistikgruppen>
Telephone: +46-(0)31-786 51 31

Table of content

1.	Introduction.....	4
2.	Road costs.....	5
2.1.	Operating costs.....	5
2.2.	Environment.....	6
3.	Rail costs.....	7
3.1.	Rail capacity.....	7
3.2.	Engine costs.....	8
3.3.	Empty wagon costs.....	8
3.4.	Using wagon costs.....	9
3.5.	Environment.....	9
3.6.	Social economic costs.....	11
4.	Terminal costs.....	13
4.1.	Social economic costs.....	13
5.	Demand for transport.....	15
5.1.	The commodity flow survey.....	15
5.2.	The transport operators.....	15
5.3.	Combining sources.....	16
6.	References.....	18

1. Introduction

This report aims at providing general input data to be used in the Heuristics Intermodal Transport model (HIT-model). A user of the HIT-model can, of course, use their own input data, however, a completely new data collection for each problem studied in the model is very time consuming. It can also be assumed that many of the fundamental data is the same in several cases, e.g. basic cost data. It is therefore appropriate to build a database of general input data. The general input data will consist of rail, road and terminals costs and emission for basic equipment types. Time windows and train time tables will not be included as these are dependent on each case.

This report will focus on Swedish conditions and analyses aimed at a strategic level. It should be noted that the HIT-model always works on a detailed level with exact timetables, volumes, transport times etc. This level of detail is needed, even if the intended level of analysis is strategic, to make a realistic representation of the transport system. However, care must be taken not to make more detailed analysis of the output data than the quality of the input data used can support. Even if the HIT-model always gives very detailed output, it might not be appropriate to analyse the output on that level. The input data in this report is adapted to this strategic aim.

The data presented is production costs. There is a difference between cost and price. Cost is the cost to produce a service, while price is what a customer will have to pay to use a service and can be affected by many more factors than the actual cost of transport. The cost data is for the year 2010, unless otherwise stated. All costs are in Swedish kronor, kr (SEK).

Cost calculation is not an exact science and the types of costs included and their estimation can vary between different calculations. Perhaps the most important thing to know about cost calculations is that they never will be completely correct. Of course, one should always try to make the calculations as good as possible, but it is also important to realise that the right level of detail must be used and it should be the same level of detail in all aspects of the calculation. For example, it is not necessary to calculate the specific tax effects for the company of pensions fees included in the salary, while at the same time only using a rough estimate of the actual salary paid. The level of detail in the calculations should be matched to the quality of the input data and the intended use of the output data.

2. Road costs

Lorries used in road only transport can be represented by three typical types of lorries. The large 25.25 lorries and standard semi-trailer lorries. The first types represent two very common types used for long distance road haulage in Sweden. Semi-trailer lorries are used for international destinations as the long 25.25m lorries are not allowed outside Sweden. Semi trailer lorries adapted to transport ISO-containers are also common, but they almost exclusively transport containers to and from the ports.

The 25.25 m lorry can consist of a lorry with three axles and a trailer with four axles. Loading capacity is 40 tons and the average speed is 80 km per hour. The semi-trailer lorry consists of a lorry with two axles and a semi-trailer with three axles. Loading capacity is 25 tons and the average speed is 80 km per hour.

The intermodal transport lorries can be represented by four typical types of lorries. The 25.25 m lorry, the standard semi-trailer with trailer adapted for intermodal transport, a lorry with swap bodies only, and the ISO 40 foot container lorry. The lorries uses 13.6m semi-trailer and/or 7.82 m swap bodies. The 25.25 m lorry is assumed to consist of a lorry with three axles, a 7.82 m swap body, a two axle dolly and a 13.6 m semi-trailer for combined transport or a 20' container and 40' container (Sveriges åkeriföretag, 2004). Loading capacity is 37 tons. The semi-trailer lorry is a two axle lorry with a three axle semi-trailer. Loading capacity is 24 tons (Woxenius, et al., 1995). The 40 foot container lorry is a two axle lorry with a three axle container chassis semi-trailer capable of carrying a 40 foot container. Loading capacity is 26 tons (Lumsden, 1998, Woxenius, et al., 1995). The swap body lorry consists of a three axle lorry with a 7.82 m swap body and a two axle trailer with a 7.82 m swap body. Loading capacity is 25 tons and the average speed is 80 km/h.

Lorry type	Loading capacity, tonnes	Speed
Trailer	24	80
Swap body	25	80
40'	26	80
25.25 m	37	80

Table 1 Recommended lorry data

The length each lorry occupies on a rail wagon will depend on the rail wagon type used. See chapter 3.1.

2.1. Operating costs

In general, an exact estimation of the costs to operate a train or a lorry is very hard. Larger hauliers, for example, get better deals on new lorries, fuel, maintenance, loans, etc. than smaller hauliers. The skill of the driver also affects the fuel consumption and wear and tear on the lorry. Similarly, the topology also greatly affects fuel consumption. Added to this is the difference in administration costs, garage, etc. The main cost difference, however, lies between trailer lorries and the bigger 24 - 25.25 m lorries, mainly because of the weight difference. The 18 m lorry with two swap bodies has similar costs as trailer lorry, mainly due to similar weigh and equal number of axles. To differentiate between different types of trailers and between 24 m lorries and 25.25 m lorries and different types of load units is not meaningful, since the normal cost variations among these vehicles are to large (Sveriges åkeriföretag, 2005). It is therefore sufficient to calculate cots for only two types of lorries.

All trailer lorries and the swap body lorries will be given the same costs and all 25.25 m lorries will be given the same costs.

Road transport costs can be estimated at 12 - 15kr per lorrykm, including salary costs. Revised and updated calculations from Flodén (2007) shows a transport cost of 15.5 kr/km for a 25.25m lorry and 12.9 kr/km for a trailer lorry. Recommended input data to the HIT-model, based these calculations are:

Lorry type	Time dependent SEK/hour	Distance dependent SEK/km
Trailer, swap body, 40'	598	4.40
25.25 m	653	6.17

Table 2 Recommended lorry costs

2.2. Environment

Bäckström, et al. (2009) as calculated typical environmental emissions for intermodal transport in Sweden with inputdata based on NTM and Artemis. The lorries are assumed to use Euro 3 class engines, which is the most common engine. The fuel used is Swedish environmental class one (Miljöklass 1). The calculations are based on an average load factor of 42% inside the load unit. Emission per km has been calculated using Bäckström's estimates and an assumption that 20% of a trip is within a city and 80% is outside the city. The environmental effect of the emission are then calculated using SIKA-data (2008), as explained in Flodén (2007).

Emission type Gram per lorrykm	25.25m lorry	Trailer, swap body, 40' lorry
HC	0.582	0.324
CO	2.76	1.56
NOx	13.68	7.06
PM	0.27	0.144
CO2	1509	769
CH4	0.0114	0.00648
SOx	0.001986	0.00101
Energy, MJ	20.91327	10.65712
Emission costs, kr	3.35	1.71

Table 3 Recommended emission data

Social economic cost estimates can be done by adding societal costs to the business economic costs. Cost estimates for emissions, noise and accidents are added according to SIKA (2008). The calculations are further explained in Floden (2007).

Recommended input data to the HIT-model are:

Lorry type	Time dependent SEK/hour	Distance dependent SEK/km
Trailer or swap body	598	7.26
25.25 m	653	10.66

Table 4 Recommended social economic lorry costs

3. Rail costs

Freight train costs are hard to estimate since the type of equipment used and their utilisation can vary substantially. The rail companies are also very reluctant to share cost data. A separate report concerning the rail cost calculations *Rail freight costs* (Flodén, 2011) is available that in more detail explains the calculations and input data used here. The report also contains an Excel file with the calculations.

Three different cost levels have been calculated for the rail costs to reflect that the cost can be substantially different depending on the equipment used and utilisation. The low cost alternative represents transport using old second-hand equipment with a high utilisation. The medium cost alternative represents modern equipment with medium utilisation. The high cost alternative represents top-of-the-line equipment with a low utilisation.

	Low	Medium	High
Engine type, electric line haul	Second hand RC4 engine	New TRAXX engine	New TRAXX engine with dual voltage system and ERTMS
Engine type, diesel haul	Second hand T44, TMZ or similar	New Vossloh Euro 4000	New Vossloh Euro 4000
Utilisation	High	Medium	Low
Wagon type	Lgjs	Sgns	Sdggmrs
Load carriers	Swap body, containers	Swap body, containers	Swap body, containers, trailers
TEU per wagon	2	3	4

Table 5 Train types

Costs has been calculated on three levels; cost of engine, cost of new rail wagon and cost of using a rail wagon. Cost of engine represents the costs associated with starting a new train, such as driver salary, engine costs and infrastructure charges related to the engine and train. Cost of a new rail wagon includes cost for the wagon and energy consumption and infrastructure charges related to the weight of the empty wagon. Cost of using a wagon is the costs for the energy consumption and infrastructure charges of the freight loaded onto the wagon.

Note that it is not possible to “change” wagons by e.g. taking the summary cost from the Sdggmrs-wagon and using it with engine data from the T44 engine, since the energy consumption for the wagon is based on the engine type used. However, these “change” calculations can easily be performed in the separate Excel-file with cost calculations that is available with the report *Rail freight costs* (Flodén, 2011).

3.1. Rail capacity

Intermodal freight transport in Sweden is today almost exclusively operated as block trains, which are assumed in these calculations.

Several different rail wagons and wagon manufacturers exist. The most common types of wagons for intermodal transport in Sweden are Lgns, Sgns and Sdggmrss. A two-axle standard container wagons type Lgns has a length of 17.1 meters. The wagon can carry two 20' containers/swap bodies or one 40' container.

The type Sgns is a four-axel wagon that can carry three 20' containers/swap bodies or combinations of 20', 30' and 40' containers/swap bodies. The wagon length is 19.6 meters (Green Cargo, 2011).

Trailers are normally transported in sdggmrss wagons, which are equipped with "pockets" to accommodate the wheels of the trailer. These are longer six-axle wagons (34.2 meters) which can carry two trailers or four 20' containers/swap bodies, or combinations thereof.

When used in the HIT-model, the wagon length is used to input the loading capacity of the train. The full length of the total number of wagons on the train is used as input, e.g. 10 Lgns wagons is input at 171 meters. The capacity each load unit occupies on the train is input as a part of the lorry type and calculated based on the wagon lengths and capacities above, e.g. a swap body lorry with two swap bodies loaded on a Lgns wagon will occupy the full wagon, thus requiring the capacity 17.1 meters.

Lorry type	Lgns	Sgns	Sdggmrss
Trailer	n/a	n/a	17.1
Swap body	17.1	13.1	17.1
40'	17.1	13.1	17.1
25.25 m	25.6	19.6	25.6

Table 6 Length capacity required on the train per wagon type

3.2. Engine costs

The engine cost includes the cost of the engine, energy consumption of the engine, maintenance, track charges for the train service and the gross weight of the engine and the personnel cost.

Recommended input data to the HIT-model are:

		Low	Medium	High
Electric train	Time dependent SEK/hour	739	1299	1871
	Distance dependent SEK/km	11.60	10.40	12.05
Diesel train	Time dependent SEK/hour	783	1093	1436
	Distance dependent SEK/km	33.15	23.25	24.40

Table 7 Engine line haul costs

3.3. Empty wagon costs

The wagon cost includes the cost of the wagon, energy consumption, maintenance and track charges by gross weight. This is the costs for using an empty wagon, which is represented by using the empty weight to calculate energy consumption.

The cost refers to the time wagons are running in a train. Wagons are also tied up at terminals for a large part of the day, however, the costs for waiting have been included in costs presented here. No cost should thus be allocated for waiting time when this data is used. This can be changed in the Excel sheet by changing the field “Time in traffic” to include waiting time.

The cost of reserve wagons, i.e. spare wagons to use when wagons are out of service for maintenance, repairs etc. is not included.

Recommended input data to the HIT-model are:

		Low	Medium	High
Electric train	Time dependent SEK/hour	7.26	13.45	46.31
	Distance dependent SEK/km	0.39	0.56	1.07
Diesel train	Time dependent SEK/hour	33.15	23.25	24.40
	Distance dependent SEK/km	7.26	13.45	46.31

Table 8 Empty wagon costs

3.4. Using wagon costs

This is the cost to transport something on the rail wagon. This includes the added energy consumption and track charges by the new weight. However, all capital costs are already allocated to the empty wagon. The calculations assume a fill rate of about 40% in each load unit.

Recommended input data to the HIT-model are:

		Low	Medium	High
Electric train	Time dependent SEK/hour	-	-	-
	Distance dependent SEK/km	0.46	0.64	0.71
Diesel train	Time dependent SEK/hour	-	-	-
	Distance dependent SEK/km	0.86	1.04	1.14

Table 9 Using wagon costs

3.5. Environment

Freight trains in Sweden purchase only electricity from renewable sources which gives very low emissions when electric line haul is used. However, it can easily be argued that it is not possible to buy only a part of the electricity on the market, but that the emissions should be estimated according to the national mix of energy sources. The electricity mix can also be substantially different in other

countries with less renewable energy sources. However, emissions in these calculations are based on the electricity mix purchased by the Swedish rail administration and contain only renewable energy sources, mainly hydropower. The calculations are based on emission data from Bäckström, et al (2009).

Recommended input data to the HIT-model are:

	Gram emission per enginekm or wagonkm	Low	Medium	High
Engine	CO2	0.164	0.200	0.200
	NOx	0	0	0
	HC	0.00060	0.00073	0.00073
	CO	0.00431	0.00525	0.00525
	PM	0.000072	0.000088	0.000088
	SO2	0	0	0
	Energy, MJ	8.67	10.56	10.56
	Emission costs, SEK	0.21	0.21	0.21
Empty wagon	CO2	0.026	0.048	0.084
	NOx	0	0	0
	HC	0.00010	0.00018	0.00031
	CO	0.00068	0.00127	0.00221
	PM	0.000011	0.000021	0.000037
	SO2	0	0	0
	Energy, MJ	1.37	2.55	4.45
	Emission costs, SEK	0.00004	0.00008	0.00014
Using wagon	CO2	0.044	0.075	0.082
	NOx	0	0	0
	HC	0.00016	0.00027	0.00030
	CO	0.00115	0.00196	0.00215
	PM	0.000019	0.000033	0.000036
	SO2	0	0	0
	Energy, MJ	2.30	3.95	4.33
	Emission costs, SEK	0.00007	0.00006	0.00011

For diesel line haul, there is a large difference between old and new engines. A modern engine might have, for example, almost half the emissions of NO_x, HC and PM compared with an old engine (Banverket and SIKa, 2002). The calculations are based on emission data from Bäckström, et al (2009). Note that emission data for rail engines are difficult to get. The emissions are therefore based on data for new and modernised T44 diesel engines.

Recommended input data to the HIT-model are:

	Gram emission per enginekm or wagonkm	Low	Medium	High
Engine	CO2	6424.44	5134.48	5156.00
	NOx	148	34	35
	HC	6.13	0.97	0.98
	CO	12.00	5.73	5.75
	PM	4.23	0.85	0.85
	SO2	1.03	0.82	0.83
	Energy, MJ	3.71	2.96	2.98
	Emission costs, SEK	20.00	10.25	10.29
Empty wagon	CO2	168.14	215.22	376.64
	NOx	3.9	1.4	2.5
	HC	0.16	0.04	0.07
	CO	0.31	0.24	0.42
	PM	0.11	0.04	0.06
	SO2	0.027	0.035	0.060
	Energy, MJ	0.10	0.12	0.22
	Emission costs, SEK	0.52	0.42	0.74
Using wagon	CO2	282.48	333.59	365.88
	NOx	6.5	2.2	2.5
	HC	0.27	0.06	0.07
	CO	0.53	0.37	0.41
	PM	0.19	0.06	0.06
	SO2	0.045	0.054	0.059
	Energy, MJ	0.16	0.19	0.21
	Emission costs, SEK	0.87	0.09	0.06

Table 10 Diesel line haul emissions

3.6. Social economic costs

Social economic cost estimates can be done by adding societal costs to the business economic costs. Cost estimates for emissions, noise and accidents are added according to SIKA (2008).

Recommended input data to the HIT-model are:

		Low	Medium	High
Engine	Time dependent SEK/hour	739	1 299	1 871
	Distance dependent SEK/km	11.82	10.61	12.26
Empty wagon	Time dependent SEK/hour	7.26	13.45	46.31
	Distance dependent SEK/km	0.39	0.59	1.07
Using wagon	Time dependent SEK/hour	-	-	-
	Distance dependent SEK/km	0.46	0.64	0.71

Table 11 Societal electric line haul costs

		Low	Medium	High
Engine	Time dependent SEK/hour	783	1 093	1 436
	Distance dependent SEK/km	53.15	33.50	34.68
Empty wagon	Time dependent SEK/hour	7.26	13.45	46.31
	Distance dependent SEK/km	1.21	0.69	0.89
Using wagon	Time dependent SEK/hour	-	-	-
	Distance dependent SEK/km	1.82	0.42	0.18

Table 12 Societal diesel line haul costs

4. Terminal costs

The cost of loading and unloading at a terminal handling can vary substantially depending on the type of terminal. The terminal activities normally consists of shunting of the train and terminal handling, where the load units are load and unloaded of the train.

Sommar (2010) calculates the costs for four types of terminals. The costs are per handled unit. A small terminal is assumed to handle 25 000 TEU annually, a medium terminal handles 50 000 TEU annually, a large terminal handles 100 000 TEU annually and a line terminal is assumed to handle 15 000 TEU annually.

Recommended input data to the HIT-model are:

	Small terminal	Medium terminal	Large terminal	Line terminal
Cost per load unit, SEK, including shunting	320	268	239	257
Cost per load unit, SEK, excluding shunting	256	182	166	257

Table 13 Terminal handling costs

The emissions from terminal handling come from shunting and the diesel powered handling equipment at the terminal. Bäckström, et al. (2009) estimates the emissions from terminals. His calculation includes shunting, empty running, multiple lifts etc. at the terminals. Note that the assumptions are not identical to the assumptions in the terminal cost calculations by Sommar. However, it is not possible to calculate emissions based on Sommar's data, or to calculate costs based on Bäckström's data. The emission costs have been calculated based on the data from Bäckström using the cost estimates according to SIKA (2008).

Recommended input data to the HIT-model are:

Gram emission per terminal handling of a load unit	Small terminal	Medium terminal	Large terminal
CO ₂	5 367	6 163	8 286
NO _x	56	61	76
HC	22	23	25
CO	35	39	47
PM	2,4	2,8	3,8
SO ₂	0.000017	0.000020	0.000027
Energy, MJ	74	85	114
Emission costs, SEK	12.62	14.22	18.56

Table 14 Terminal handling emissions

4.1. Social economic costs

Social economic costs can be calculated according to the same principles as for the rail transport. The calculations are based on costs from Sommar and emissions from Bäckström et al.

Recommended input data to the HIT-model are:

	Small	Medium	Large
Cost per lift, SEK	333	282	258
Cost per lift, SEK, excluding shunting	269	196	185

Table 15 Societal terminal handling costs

5. Demand for transport

A key input data in any transport model is the demand for transport. Unfortunately, getting access to good transport statistics is a reoccurring problem in all transport research. There is no existing national freight flow database with a detailed geographical coverage in Sweden today. It is therefore recommended that the model user have access to their own freight flow database. However, a brief overview will be given here into other potential sources of flow data.

5.1. The commodity flow survey

The main source for freight flow statistics in Sweden is the commodity flow survey (Varuflödesundersökningen, VFU). The survey is sent to about 12 000 local units¹ and concerns their arriving and departing shipments (including import and export). The VFU separates itself from previous statistics by its focus on the individual shipment. The previous national transport statistical studies were mode specific and targeted the individual lorry etc. The VFU focuses on individual shipments and maps the shipments origin, destination, weight, value, load unit, the sequence of transport modes used during the entire transport chain, commodity class, etc. Import and export data is included in the survey. The geographical level of detail is very high with each shipment being recorded at a five digit zip code level. Not all lines of businesses are included in VFU, since it focuses on manufacturing and wholesale industry with added data from mining, agriculture and forestry from other sources. The VFU study has been carried out three times, in 2001, 2004/2005 and in 2009. Unfortunately, the uncertainty in VFU is very high when looking at a detailed level. The data for the 2001 study consisted of 922 913 observations which is too few to have any acceptable quality for modelling when looking at e.g. a municipality to municipality level ($298 \times 298 = 88\,804$ transport relations²). However, aggregate data have lower uncertainties. The aggregation of all goods sent from a county³ (län) has an uncertainty of about 10-20%⁴ for a county. Detailed data from the VFU-survey can be made available for researcher from the Swedish agency for transport policy analysis (Trafikanalys), who is responsible for the VFU.

5.2. The transport operators

The transport operators themselves also keep detailed statistics about their own transport. However, many operators are reluctant to share this data with others. See for example Andersson, et al., (2005). Several operators have been contacted in this project and asked about their statistics and if they would like to share statistics with this project. Their interested in the project has been great, but most has denied sharing data. This can be for confidentiality reasons, but more often they simply do not have the time and resources to make special runs in their databases to extract the data.

The operators will, of course, have some kind of “paper trail” for all shipments, but this must be input in a computerised database to be possible to use for modelling. Therefore, most projects are limited to using the data already in the operators’ databases as it is far too resource consuming to manually check the paper documents of several hundreds of thousands of shipments. The operators might also have more detailed information in other local databases within the organisation, but again

¹ A local unit is defined as each address, or building(s), where a company carries out economic activity.

² Including export/import destinations.

³ Sweden is divided into 21 counties.

⁴ The lowest being Norrbottens län with 3.9% and the highest Blekinge län with 38.4%. 13 of the 21 counties have an uncertainty less than 20%. Goods from these counties represent 74.6% of the total goods flow. 4 counties have an uncertainty less than 10%, representing 38.3% of the goods flow. 2 counties have an uncertainty greater than 30%, representing 4.3% of the goods flows. A confidence interval of 95% was used (SIKA, 2001).

most projects are limited to what the operators can provide without any major work effort. This text is therefore based on what the operators have collected and has access to in their current databases.

It was found that there is no uniform way the operators keep their statistics. A few keep very details statistics of each shipment with destination, weight etc. in a common database, but most lack a common database or has incomplete data in some ways. The main problems identified in the operators data is:

- the geographical level of detail
- incomplete data
- problems in following an individual shipment through terminal handling, transshipment etc.

The geographical level of detail was limited in the operator's statistics and varied between the operators. When asked, the operators were either unwilling to share the exact destinations for their shipments, or they lacked to data. One operator, for example, had only access to data on a regional level (similar to county level), which gives a level of detail similar to the VFU data. Others had data on a more detailed zip-code level.

The data was also often incomplete in some aspects. Data fields such as weight, volume, number of pallets etc. was not always filled out for all shipments. The caused problems when aggregated data was offered by the operators and it was not possible to know how many data fields had been missing in the aggregation. One operator explained this by that their focus was on what affected their business. For example, if a customer orders a full truckload, then the only thing interesting for the operator is that the capacity of one truck is needed. They have no interest in recording what was actually loaded on the truck. For smaller shipments, the concept of "fraktdragande vikt" or volumetric weight is used. The weight of low density or odd size goods is converted to a chargeable weight based on the size of the shipment. A calculation converts the actual weight of the shipment to a new "imagined" weight for charging freight in accordance with how much capacity the shipment occupies on the lorry. Also known as cubic weight or dimensional weight. Thus, the true weight etc. is not always recorded when it is not used to charge the customer. Similarly, the type of commodity transported was seldom known by the operator.

The large transport operators commonly use terminals in a hub-and-spoke or similar system. Shipments are then moved between different lorries during the transport. Most operators had access to data on how much was sent between the terminals, i.e. how much the lorries transported. However, some had problems following an individual shipment through the terminal in their data. Thus, they know the flows that came into the terminal and the flows that left, but they could not connect them and say which shipment that came from where.

5.3. Combining sources

Several sources can be combined to create a better database. Unfortunate, this also faces a number of difficulties. One is the issue of overlapping data. For example, a shipment sent by intermodal road-rail transport will occur both in the road data and in the rail data. Another example is that the operator data will also be a part of the national statistics which makes them difficult to combine. Also, the operator data is not the results of a statistical survey with random selection which makes it

doubtful if it can be used scale up the data to represent flows outside the operator. Different definitions of variables, such as geographical regions, and missing data are other issues.

One attempt to combine data was made in Flodén (2007), where flow data from the three largest Swedish operators was used to provide the geographical distribution of the flows and the commodity flow survey (VFU) was used to provide the volumes. The VFU database has a good national coverage and gives accurate values on the total flows, but is less accurate on the detailed flows. The forwarder data, on the other hand, lacks the national scope but includes very detailed data on transport flows. These two data sources can be combined by utilising their strengths. The database was successfully used in the HIT-model.

6. References

- Andersson, D. & Woxenius, J. & Flodén, J. & Lammgård, C. & Saxin, B., 2005, *Trafikslagsövergripande databas för godstransporter - en förstudie för SIKA/Samgodgruppen och Sveriges Transportindustriförbund*, SIKA, Stockholm
- Banverket & SIKA, 2002, *Nya banavgifter? Analys och förslag*, Statens institut för kommunikationsanalys, SIKA rapport, 2002:2, Stockholm
- Bäckström, S. & Bohlin, M. & Franzen, U. & Jonsson, P., 2009, *Miljökalkyler för intermodala transportkedjor - Detaljerad beräkningsmetodik och relevanta schablonvärden*, WSP Analys & Strategi, SIR-C Swedish Intermodal Transport Research Centre, Rapport nr. 2009:6,
- Flodén, J., 2007, *Modelling intermodal freight transport : the potential of combined transport in Sweden*, Doctoral thesis, Department of Business Administration, School of Business, Economics and Law at University of Gothenburg, BAS Publishing, Göteborg, <http://hdl.handle.net/2077/17141>
- Flodén, J., 2011, *Rail freight costs- Some basic cost estimates for intermodal transport*, Department of Business Administration, School of Business, Economics and Law at University of Gothenburg, Swedish Intermodal Research Centre Sir-C Göteborg
- Green Cargo, 2011, *Green Cargo Godsvagnar*, <http://www.greencargo.com/sv/Godsvagnar/Start/Oversikt/>, Accessed february 15 2011
- Lumsden, K., 1998, *Logistikens grunder: teknisk logistik*, Lund, Studentlitteratur
- SIKA, 2001, *Varuflödesundersökningen 2001*, SIKA / SCB, Sveriges officiella statistik, SSM 071:0201, Stockholm
- SIKA, 2008, *Samhällsekonomiska principer och kalkylvärden för transportsektorn: ASEK 4*, Statens institut för kommunikationsanalys, SIKA PM, 2008:3, Östersund
- Sommar, R., 2010, *Utvärdering av intermodala transportkedjor - kostnadsmodeller* TFK, KTH, SIR-C Swedish Intermodal Transport Research Centre,
- Sveriges åkeriföretag, 2004, *Åkerihandbok 2004*, Danderyd, Sveriges Åkeriföretag
- Sveriges åkeriföretag, 2005, Telephone interview with Ulric Långberg at the Swedish Haulier Association, 7 September
- Woxenius, J. & Henriksson, A. & Sjöstedt, L., 1995, *Handbok för lastbärarval*, Rail Combi

Visualizing Transport Flows

A GIS based approach

Erik Elldér
Anders Larsson

Occasional Papers 2010:2

Institutionen för kulturgeografi och ekonomisk geografi



GÖTEBORGS UNIVERSITET
HANDELSHÖGSKOLAN

Visualizing Transport Flows

A GIS based approach

Erik Eldér

Anders Larsson

Occasional Paper 2010:2

Department of Human- and Economic Geography

School of Business, Economics and Law
University of Gothenburg, Sweden

Table of contents

1. Introduction	5
2. Principles of visualisation of flows in cartography.....	6
3. Installing the ETGeoWizard extension.....	11
System requirements	
Installation process	
Loading ETGeoWizards extention into ArcGIS	
4. How to generate lines between nodes.....	13
Introduction	
Preparing inputs	
Generate lines from the input data	
5. How to Visualize flows and create maps	18
Modify lines	
Create a map layout for printing	
6. Future developments	22
References.....	23
Appendix.....	24

1. Introduction

This paper reports the result of a joint project between the Department of Human and Economic Geography and the Department of Business Administration, Logistics and Transport Research Group both at the School of Business, Economics and Law, University of Gothenburg.

The purpose of the project is to visualize transport flows in a GIS environment and has been carried out mainly by Erik Elldér, supervised by Dr. Anders Larsson at the Department for Human and Economic Geography. Valuable inputs including transport flow data have been provided by Dr. Jonas Flodén, Department of Business Administration, Logistics and Transport Research Group.

The main part of the report is a step-by-step user guide but it starts with a general overview of cartographic visualisation in order to inform about possibilities and limitations that the user of this software tool should reflect on before continuing to the practical part of the paper.

Part one as described above gives a conceptual overview of principles of visualisation.

This is followed by step-by-step guides to :

- Installation of ArcGIS extension ET Wizards99
- Work-process to generate lines
- Visualize data and create print-ready maps in the ArcGIS environment

A description of basic geographical data can be found in the appendix.

2. Principles of visualisation of flows in cartography

The aim of this section is to introduce basic concepts and principles for cartographic visualisation. Focus will be problems and possibilities to visualise flow-data on maps, both printed paper maps as well as digital on-screen representations. Since this report is concerned with the implementation of flows in a GIS software environment some final reflections on the GIS – cartography relationship will be included.

Cartography is concerned with drawn representation of geographical space (Robinson, A.H., J.L. Morrison et. al. 1995). This wide definition includes several aspects and stages from the initial idea to a final map. It is important to emphasize that this is almost always a communication process which include testing and feed-back loops based on the interaction between the mapmaker and the map-user.

One further element to consider is the place of cartographic visualisation in a GIS environment. The figure below illustrates a typical GIS work-flow from initial data collection to final result. Not all steps are necessarily included in all projects. The grey boxes indicate the steps covered in this report.

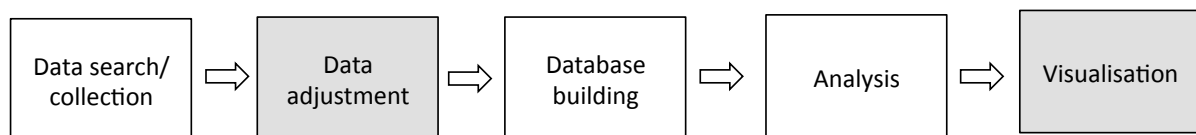

Figure 1: Simplified GIS-project workflow with major components. *Source:* Developed from definition by Swedish mapping, cadastral and land registration authority.

There are some aspects to the figure that need to be developed. One is the importance of a well defined problem in order to guide the initial stages of the process. As in all data-driven analysis contexts input data is a key concern. In a GIS this include two types of data, geometric- and attribute data. Geometric data is all data with a direct territorial connection to a position on Earth, often through coordinates attached to a reference system. Attribute data on the other hand comprises all types of information that can be linked to the geometric data, via a common identifier. In the case of customers per post-code area, the geographical form of each post code area defined by its coordinates will be the geometric data and number of customers is the attribute, linked via the post-code number.

The fact that geometric data is defined by its absolute position on Earths surface means that users need to be aware of the fact that different reference

systems exist and that data often needs to be converted between for example global and national systems.

In this project geographical data is collected and adjusted to the area of interest. The first stage where the user needs to be involved in the process is the adjustment of attribute data, namely to format transport flow data according to a specific file structure. This is described in detail later in this document.

Database building and analysis are not covered here since these steps are not part of the current tool. We will instead continue to the last stage, namely visualization. A number of important aspects regarding cartographic visualization in general and visualization of flows in particular will be discussed. The reason for this is to provide the user with a basic understanding of the possibilities and even more importantly the limitations of cartographic representation.

Cartographic representation can be described as three different but interrelated processes: (Harrie 2008)

- The **communication** process – emphasizes the importance of visualization as communication between the producer and the user. It puts focus on the cartographer's ability to understand user needs and to what extent these can be clearly defined and fulfilled through the language of maps.
- The **production** process – includes a number of stages similar to the figure 1 above. Especially important are decisions on the contents of the map in terms of final output media, generalization and information density.
- The **design** process – the final stage where the result from the previous processes is operationalised through the use of cartographic principles and tools. Of central importance for both professionals and occasional mapmakers is the need for testing and re-design.

In this particular project, the two first processes are already pre-set through external conditions of fixed input data, geographical scope and users. Therefore in the following we will concentrate primarily on design issues.

All information on a map is visualized using three different object-types; points, lines and polygons (areas) together with text as a fourth component. These three object types can be modified based on size, shape, texture and color. Figure 2 below illustrates possible combinations of objects and modifications. In the last column is indicated what type of data is best shown by the respective categories. Since this project is limited to visualization of quantitative transport-flow data, we are primarily using either size, colour values or texture, or to some extent combinations of these.

	<i>Points</i>	<i>Lines</i>	<i>Areas</i>	<i>Best to show</i>
<i>Shape</i>		<i>possible, but too weird to show</i>	<i>cartogram</i>	<i>qualitative differences</i>
<i>Size</i>			<i>cartogram</i>	<i>quantitative differences</i>
<i>Color Hue</i>				<i>qualitative differences</i>
<i>Color Value</i>				<i>quantitative differences</i>
<i>Color Intensity</i>				<i>qualitative differences</i>
<i>Texture</i>				<i>qualitative & quantitative differences</i>

Figure 2: Basic cartographical visual variables. *Source:* Krygier and Wood (2005)

Flows in this case are represented by data describing the amount or value of goods transported from one node via one or many nodes to a final destination node. This could be visualized by linking information to each node illustrating the significance of each node as either a sender or receiver of goods. Another method is to focus on the relation between nodes and link data to the line connecting the start and the end of a flow.

In this project we have adopted the later model using lines as connectors and by varying the size of lines illustrating the quantitative indicator such as amount of goods or cost of transport. In this pilot-stage, size is not combined with texture or shapes such as arrows to indicate direction. Furthermore it is possible to visualize both nodes and connector lines together in the same map (see top map in figure 3 below), showing for example terminal capacity and aggregated flows between terminals.

In this application, flows are represented by straight lines between start- and finish points, which, for reasons of simplification in calculation of connectivity networks and minimizing database complexity, is a preferable strategy. But this has its limitations when accuracy and representation of reality is important. Figure 3 bottom map illustrates how flows along actual rail- routes provide a more accurate picture of aggregated flows on the respective rail links.

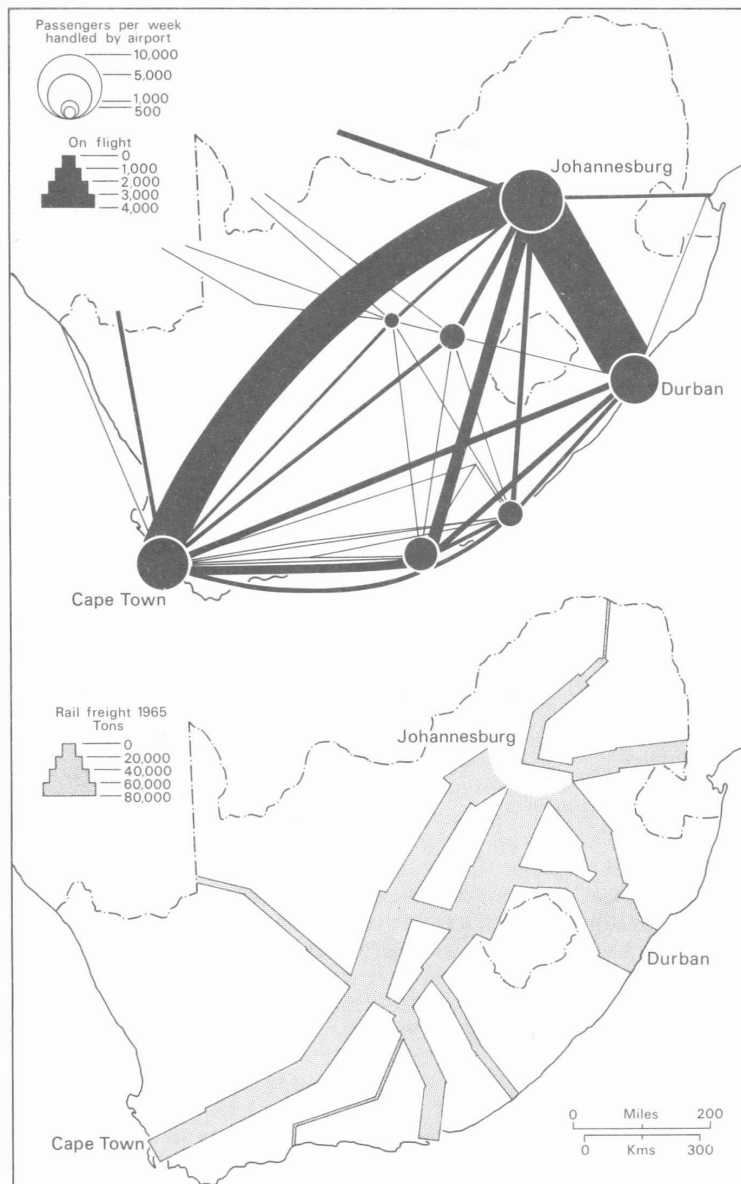

Figure 3: Examples of transport flow visualization. *Source:* Lawrence (1971)

The choice between the two ways of illustration is to a large extent guided by the input data. The lower map is only possible to construct if flows are represented as journeys from one start via a number of identified nodes to the final destination in a real network, while the straight-line map only needs information on origin and destination of aggregated flows

One further aspect of importance is the medium for communication of the final product. Traditionally maps have always been printed on paper and distributed but with the growth of communication and computer technologies maps are

more and more viewed on computer monitors. This puts new dimensions to cartography in terms of for example: technology dependence and limitations, producer-user interactivity and screen resolution and color representation (Kraak and Brown 2001).

This case is primarily aimed towards producing visual images of complex transport flow data on screen that then can be printed maps and digital output for publications and presentations. Output is therefore less developed and depending entirely on the GIS software printer drivers, the respective user operating system and end-user printers.

In this chapter we have presented a brief introduction to cartographic principles and discussed problems and possibilities related to the visualization of transport flow data. The following chapters contain step-by-step instructions for users in order to start producing flow maps.

3. Installing the ETGeoWizard extension

System requirements

The Visualization of Transport Flows (VITF) module is implemented in the ArcGIS desktop software environment, therefore ArcGIS Desktop (ArcView 9.2 version or higher) is required.

All data and extensions can be downloaded from the following link:

<http://www.hgu.gu.se/item.aspx?id=18459>

This is necessary in order to be able to follow the instructions below.

Installation process

1. If you have a previous version of ET GeoWizards installed, uninstall it first.
2. Log on to the computer and make sure that you have the rights to install new software.
3. Unzip ETGeoWizards99_92.zip
4. Run ETGeoWizards99_92.exe (For Windows Vista, Right Click on the file in the Windows Explorer → Run as Administrator)
5. Select the installation folder on the hard disk where ArcGIS is located

Loading ETGeoWizards extension into ArcGIS

1. Open ArcMap by clicking the Start_here.mxd - file included.
2. In the Tools menu click customize.
3. Highlight the command tab. (see figure 4)
4. Click the Add from file... button and select the ETGeoWizards99_92.dll
5. Search for "geowizards" in the Show commands containing. (See figure 4)
6. From the Commands category "drag" and "drop" the 'ET GeoWizards99_92' command to any toolbar or menu preferred, by right clicking and dragging it with the cursor.
7. Click the shortcut to open ET GeoWizards main menu.

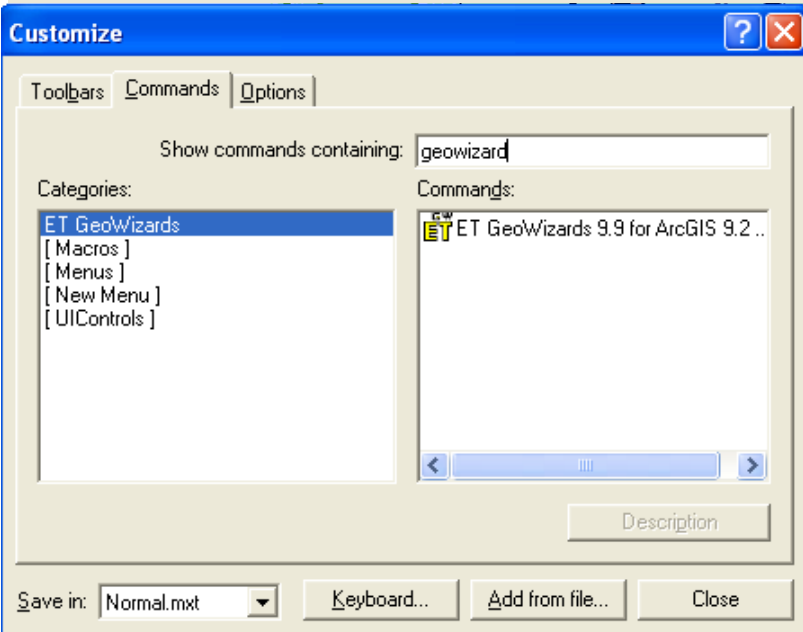
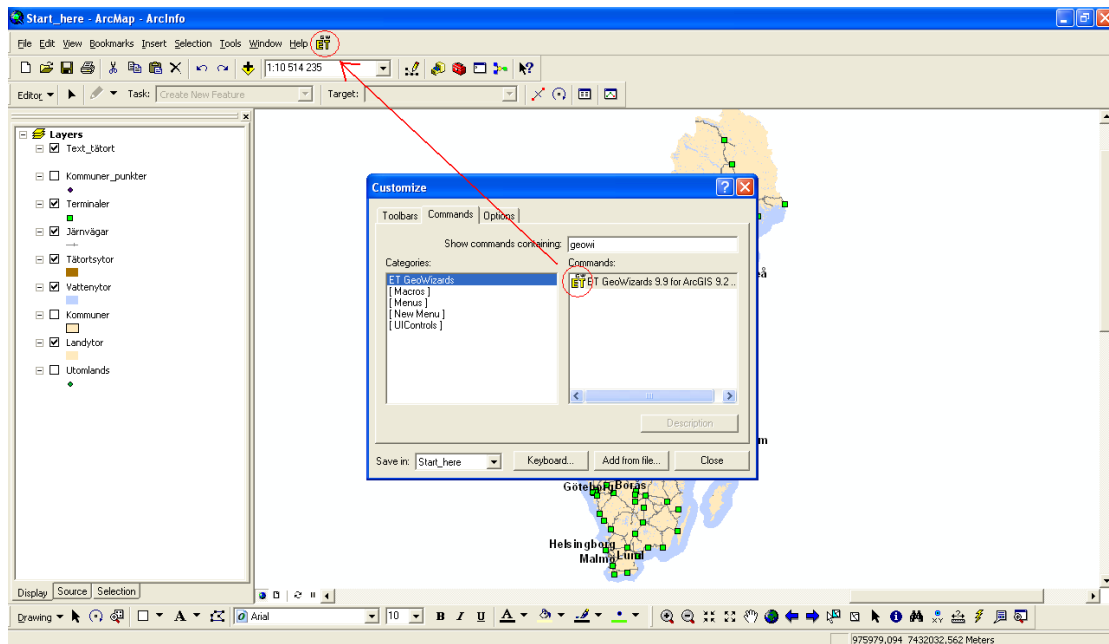

Figure 4: Loading ET GeoWizards extension in ArcGIS

4. How to generate lines between nodes

Introduction

This chapter will give a step – by – step introduction to the process of creating lines between pre-defined origin and destination points. The process starts with how to prepare input data in order to be compatible with the demands of the software.

Preparing inputs

The only input required is a space delimited text file of the following format:

```
FIELD FIELD FIELD FIELD
value value value value
x y
x y
END
value value value value
x y
x y
x y
END
value value value value
x y
x y
END
END
```

Figure 5: Basic structure of input data. The number of fields is not limited.

The information between every END will generate a line connecting the x y coordinates stated in the input text file.¹ The text on the first line (FIELD) determines the headings of the fields in the attribute table that will be connected to the generated lines. The value of every line in every field is determined by the number in values added above the x y coordinates.

N.B.! It's very important that there is one space between every value, field or coordinate.

¹ The project folder contains excel files with coordinates for terminals and municipality principal towns.

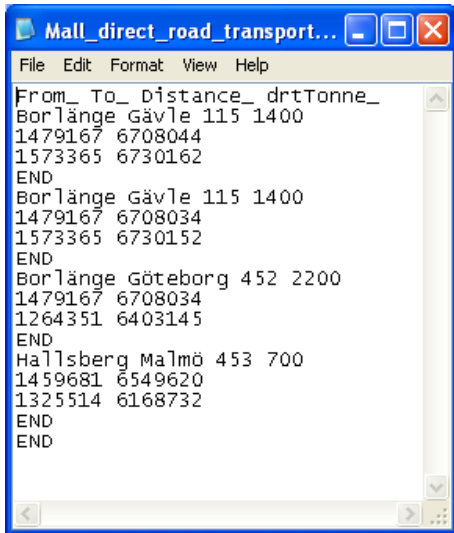

Figure 6: Example of attribute table ArcGIS generated by the VITF module

Important notes!

- Avoid using field names reserved for ArcGIS such as "Shape" or "ObjectID"
- Field names longer than 10 characters will be converted to 10 character strings
- In the free version of ET Geowizards there may be a limit to the amount of lines created from one text file. This is not tested.

Generate lines from the input data

1. Open ET GeoWizards
2. Highlight the In/Out tab in the bottom right of the ET GeoWizards window (see figure 7)

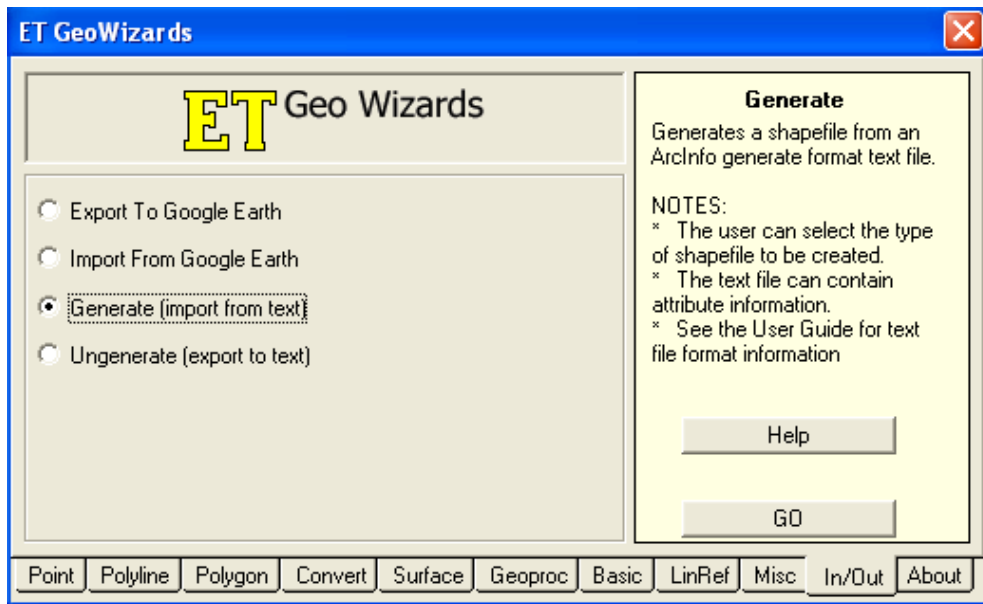

Figure 7: ETGeoWizards start dialogue box.

3. Press Generate (import from text). Then click the GO button
4. Select the input text file
5. Select data type “Polyline”
6. Select a source for spatial reference. Preferably one of the basic shapes included (the shape needs to be added to the table of contents in ArcMap)
7. Specify output shape file
8. Press Next
9. Check that the data contains attributes.

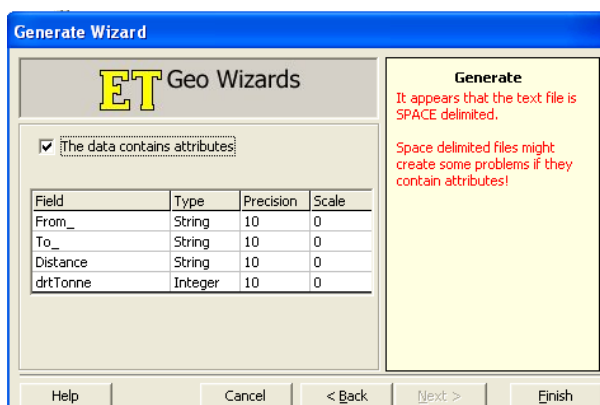

Figure 8: ETGeoWizards Generate dialogue box.

10. Make sure that all the fields from the input text file are included in the Field column. (Se figure 8)
11. If a field exclusively contains numbers it is important to specify the type of data as Integer in the Type column. This will not be possible to change after the line is generated.
12. Press Finish

The result should be a new line feature class complete with attributes stated in the input text file. See next page for illustration.

```

Mall_intermodal_transport - Notepad
File Edit Format View Help
From_ From_Terminal To_terminal To_weight Time
Kiruna Kiruna Ånge Hudviksvall 730 8
1703809 7571533
1685074 7536233
1492938 6934706
1556518 6848353
END
Falun Borlänge Göteborg Kungsbacka 1450 24
1502080 6736994
1479167 6708034
1264331 6403145
1280143 6372903
END
END

```

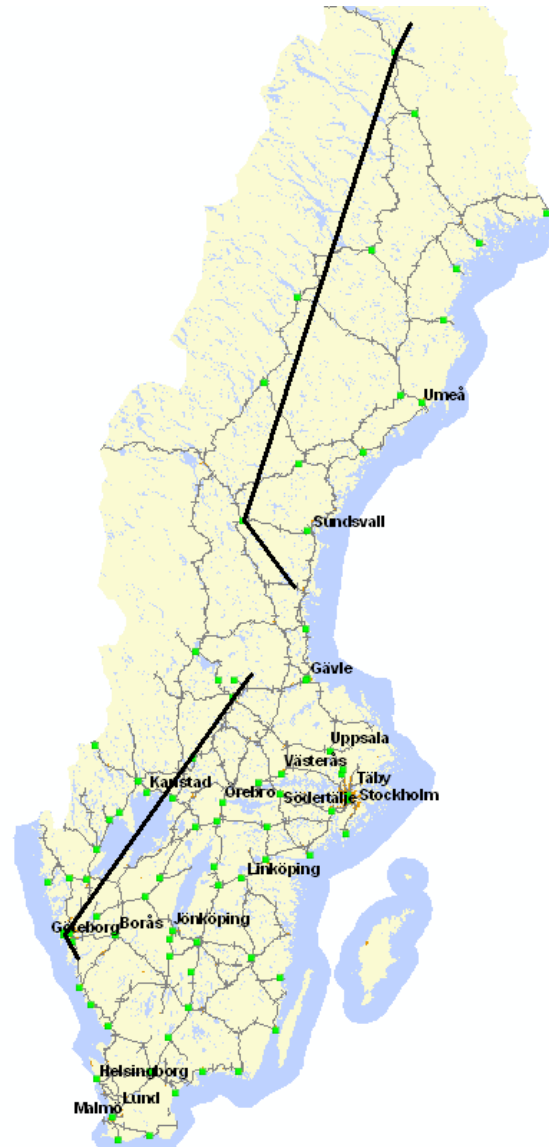

Attributes of mall_intermodal_transport

FID	Shape	From	From Termi	To termina	To	Weight	Time
0	Polyline	Kiruna	Kiruna	Ånge	Hudviksvall	730	8
1	Polyline	Falun	Borlänge	Göteborg	Kungsbacka	1450	24

Record: 1 Show: All Selected Records (0 out of 2 Selected) Options

Figure 9: Example of input data, generated lines and attribute table

5. How to visualize flows and create maps

Start by opening ArcMap by clicking the Start_here.mxd file included. For users with non or very limited experience of ArcMap it is recommended to use the ArcGIS desktop help included with ArcMap.

Modify lines

When the line shape file is generated in ET GeoWizards the next step is to change the symbology of the lines.

1. In the table of contents (see figure 12) double click the generated line shape file to view its properties.
2. Highlight the Symbology tab in the layer properties window

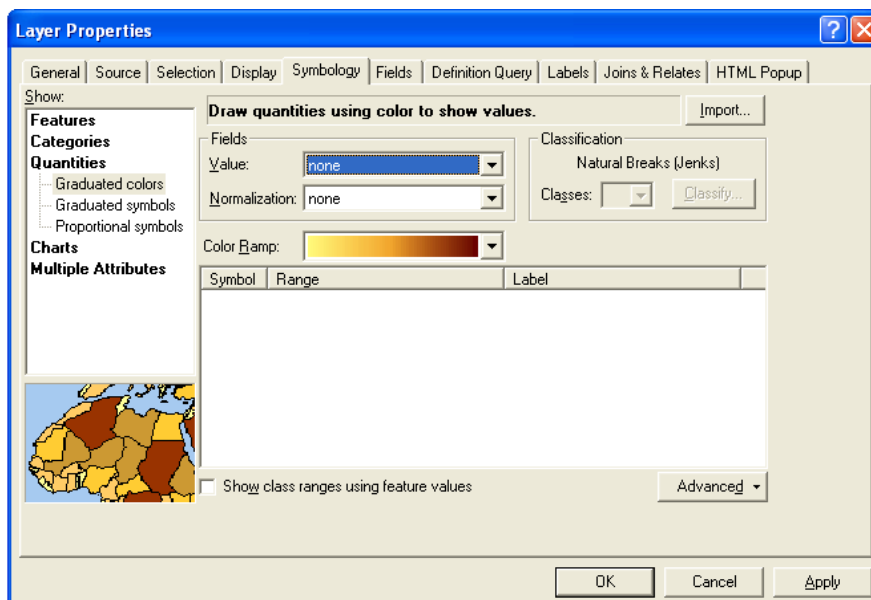

Figure 10: ArcMap Layer Properties dialogue box.

3. In the Show window, highlight Quantities (see figure 10)
4. The next step is to determine the method of symbolization, either by size (Graduated symbols) or colors (Graduated colors. Common for both methods is that you need to specify which attribute-field the visualization shall to be based on. You are also able to change the number of classes and the width of the corresponding line. (See figure 11) Note that it is possible to manually change symbol, range and label for each class by clicking each symbol.

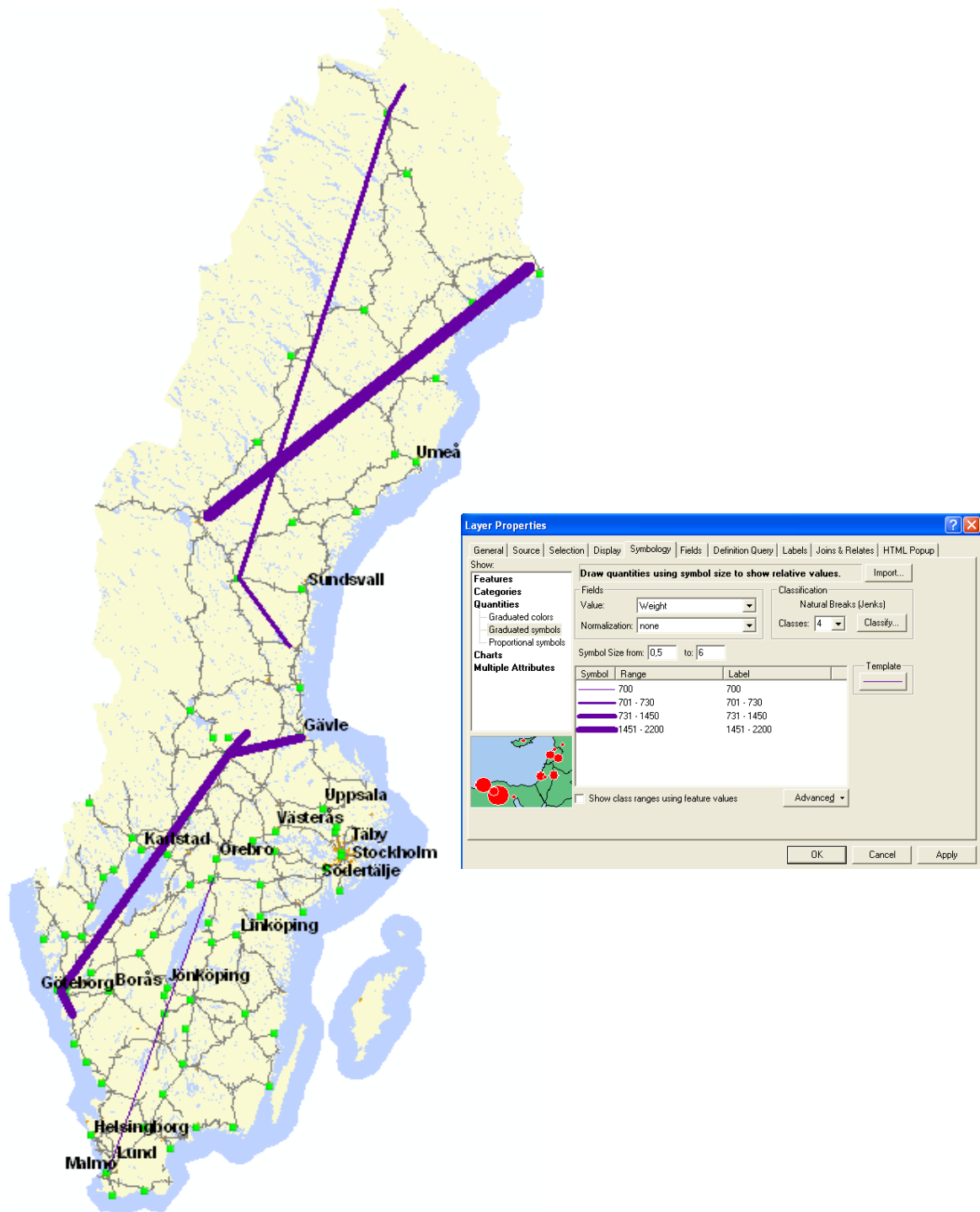



Figure 11: Layer properties dialogue and map example of Graduated symbols based on line width.
Create a map layout for printing

1. Shift to **Layout View** by clicking its symbol button () at the bottom of the screen. If you need to change anything click the () button to go back to Data view.
2. First of all decide which basic information to be visualized on your map by checking or un-checking shape files in the table of contents. (See

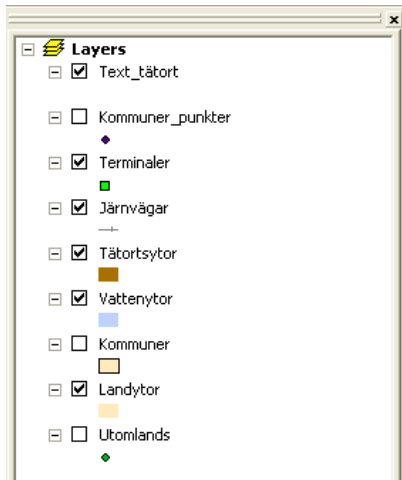



figure 12)

Figure 12: ArcMap table of contents

3. You are also able to add shape files by clicking the Add data button . If desired, change the symbols of each shape by double-clicking on its symbol.
4. In the layout view press the Insert dropdown menu to add preferred information: (see figure 13)
5. Note that Start_here.mxd already has a template complete with title, legend, north arrow and scale bar. You can change the objects content and appearance by double clicking on them.

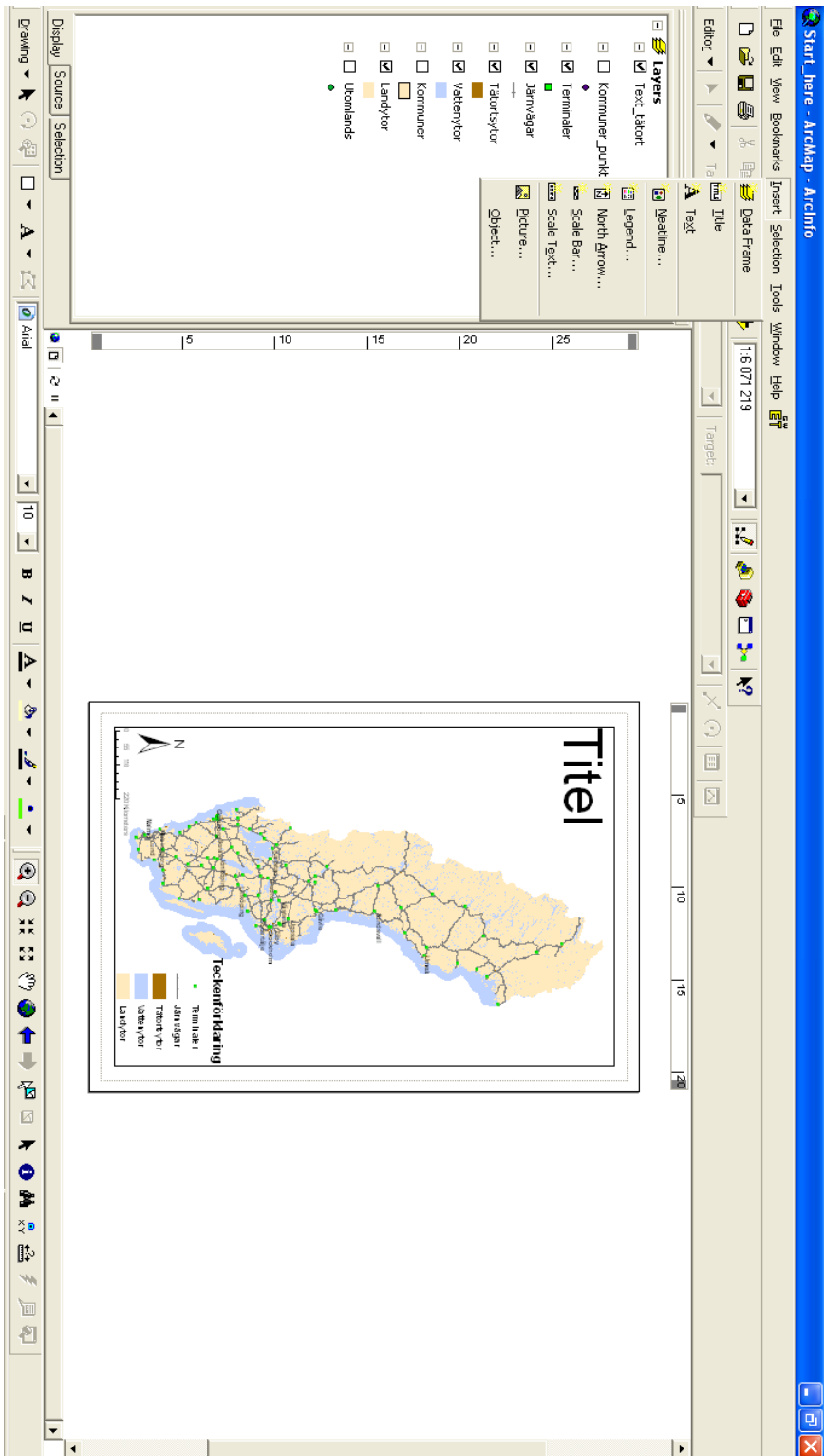

Figure 13: ArcMap Layout view

6. Future developments

The ETGeoWizards extensions to ArcGIS consist of a number of functions bundled together. ET Spatial Techniques does not provide functions separately and the Generate function is not included in the scripting implementation of ET GeoWizards. This means that there is currently not possible to construct a single short piece of code that uses the generate function and attach this it to a button or menu in ArcGIS. The next version are planned to be released together with ArcGIS 9.4 (around April 2010) and will most likely open up for a more integrated solution.

Another possibility for future developments is to create a customized version of ArcGIS with pre-defined menus and dialogue-boxes dedicated to flow data visualization. This strategy will produce a more easy to use software application, but requires more resources compared to the current set-up based on external add-on extensions.

References

Books and articles

ESRI (2004) *Getting to know ArcGis Desktop*. Second Edition Updated for ArcGIS 9. Redlands: ESRI Press

Harrie Lars (red.) (2008) *Geografisk informationsbehandling: teori, metoder och tillämpningar*. Formas, Stockholm. www.formas.se

Kraak Menno-Jan and Allan Brown (eds.) (2001) *Web Cartography: Developments and Prospects*. London and New York: Taylor and Francis

Krygier John and Denis Wood (2005), *Making Maps: A Visual Guide to Map Design for GIS*. New York: The Guilford Press.

Lawrence G.R.P (1971) *Cartographic Methods*. London: Methuen

Robinson, A.H., J.L. Morrison et. al. (1995) *Elements of Cartography*, 6th ed. New York: John Wiley and Sons.

Websites

ESRI is the developer of ArcGIS software. Website: <http://www.esri.com>

ET Spatial Techniques. Company supplying extensions to ArcGIS. Website: <http://www.ian-ko.com> The free ETGeoWizards extension to ArcMap can be downloaded from: http://www.et-st.com/downloads/etgw/ETGeoWizards99_92.zip

Swedish Map data from Swedish mapping, cadastral and land registration authority. <http://www.lantmateriet.com>

Appendix

Description of basic geographical data on Sweden together with locations of cargo terminals and ArcGIS project template. This data can be downloaded via the following link: <http://www.hgu.gu.se/item.aspx?id=18459>

File description

Coords_kommunpunkter.xls:	X and Y coordinates of Swedish municipalities principal towns
Coords_terminaler.xls:	X and Y coordinates of Swedish terminals
Coords_utomlands.xls:	X and Y coordinates of some of Sweden's top trade partners
Start_here.mxd:	ArcMap project file complete with basic shape files
ETGeoWizards99_92.zip:	Extension to ArcMap required to run the VITF
SHP folder:	Contains complete shape files visualizing Swedish land, water, urban and municipality areas, terminals, railroads and municipalities principal towns. There is also a shape file included visualizing the EU's major countries and Sweden's main trading partners.

HEURISTICS

User Guide

The Heuristics Intermodal Transport Model

HIT-Model

v. 1.0

Jonas Flodén

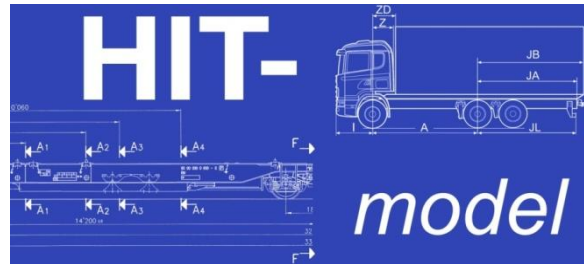

Jonas Flodén
Department of Business Administration
School of Business, Economics and Law
University of Gothenburg
P.O. Box 610
SE 405 30 Göteborg
Sweden

E-mail: jonas.floden@handels.gu.se
URL: <http://www.handels.gu.se/fek/logistikgruppen>
Telephone: +46-(0)31-786 51 31

Table of Contents

1	HEURISTICS MANUAL	4
1.1	MODEL BACKGROUND	4
1.2	MODEL CONCEPT AND PROBLEMS THE MODEL CAN SOLVE	4
1.3	WHAT IS HEURISTICS?	5
1.4	BASIC HEURISTICS	5
1.5	DEFINITION OF TERMS AND CONCEPTS	6
1.5.1	<i>All-road transport</i>	6
1.5.2	<i>Combined transport</i>	6
1.5.3	<i>Demand point</i>	6
1.5.4	<i>Demand occurrence</i>	6
1.5.5	<i>Intermodal transport</i>	6
1.5.6	<i>Intermodal terminal</i>	7
1.5.7	<i>ITU</i>	7
1.5.8	<i>Transport link</i>	7
1.5.9	<i>Train route</i>	7
1.5.10	<i>Train loop</i>	7
1.5.11	<i>Transshipment</i>	8
1.5.12	<i>Terminal</i>	8
1.5.13	<i>Terminal handling</i>	8
2	HEURISTICS	9
2.1	JENSEN PRINCIPLES	9
2.2	THE HIT-MODEL	10
2.3	FRAMEWORK CALCULATIONS	10
2.4	MODAL CHOICE	12
2.4.1	<i>Lowest Cost System</i>	13
2.4.2	<i>Maximum Weight Transfer</i>	17
2.5	END CALCULATIONS AND OUTPUT	19
2.6	A CALCULATED EXAMPLE	19
3	TIME	23
3.1	DELIVERY TIME WINDOWS	24
3.2	TIME WINDOW OVERLAP	24
3.3	COMPARATIVE DELIVERY TIME GAPS	25
3.4	DEPARTURE TIME WINDOWS	26
3.5	COMPARATIVE DEPARTURE TIME GAPS	26
3.6	OPERATING WINDOW	27
4	SIMPLIFIED FLOW CHART	29
5	DETAILED FLOW CHART	32
6	REFERENCES	37

1 Heuristics manual

This manual contains a description of the heuristics used in the The Heuristics Intermodal Transport model, the HIT-model. The heuristics have been implemented in a computer model (the HIT-model) consisting of two parts, the actual calculations model and a user input and output interface. A user guide to the full HIT-model is available in the manual entitled "User Guide".

1.1 Model background

The Heuristics Intermodal Transport model, the HIT-model, was developed as a part of Jonas Flodén's (2007) doctoral thesis, *Modelling Intermodal Freight Transport – The potential of combined transport in Sweden*. The thesis was presented at the Department of Business Administration at the School of Business, Economics and Law at Göteborg University, Göteborg, Sweden (<http://www.handels.gu.se>).

1.2 Model concept and problems the model can solve

The Heuristics Intermodal Transport model is a user-friendly model that can be run on an ordinary desktop PC. The model takes its starting point in a competitive situation between traditional all-road transport and intermodal transport, where the theoretical potential of intermodal transport is determined by how well it performs in comparison with all-road transport.

The model determines the modal split between traditional all-road transport and intermodal transport. The model will also select which lorries and load unit to use, and determine the train time table, train length etc. It is also possible to run the model as a cost calculation tool, where the modal split or transport system is, completely or partly, externally given. The modal choice assumes that the transport mode that yields the lowest transport cost is selected. However, intermodal transport must offer, at the least, the same delivery times as all-road transport. Time windows and time gaps in which the delivery times are considered equal, are used to compare time durations between the modes. The model can perform the calculations according to either societal economic costs or business economic cost. The environmental effects of the transport system are also calculated. The model can also be set to either perform the modal split calculations for each train route, or jointly for the entire system. The model can also search for either the system that sends the most goods by intermodal transport without increasing the total system cost compared to a system with only all-road transport system, or to search for the lowest cost system.

It is possible to impose restriction on the types of allowed lorries. Restrictions regarding allowed lorries, delivery times, departure times, etc. can be set individually for each transport link and time period. The length of a time period can further be set individually for each transport link. The modal split can also be controlled by a number of control parameters. A random disturbance can be added in the modal choice, where not all demand assigned for intermodal transport is actually sent by intermodal transport. The cost calculations can also be controlled to force intermodal transport to ensure that a certain percentage of the costs are higher or lower than those of all-road transport in order for them to be selected. Further control over the model can be achieved by manipulating the input data, e.g. testing the effects of different cost valuations. A user interface in Microsoft Access is used to input and output data from the model.

Output from the model is the modal choice for each demand occurrence with departure time, arrival time, train departure used, position on train, type of lorry used, number of lorries used, business economic cost, social economic cost, and environmental impact (CO₂, CO, SO₂, NO_x, PM, HC, energy

consumption and a monetary estimation). If all-road transport is selected, the model also shows the reason why intermodal transport could not be selected (e.g. violated time constraint, economic constraint, etc.). The suggested train system is output with time tables, train lengths, business economic costs, social economic costs and environmental impact.

A typical case analysed in the model could be the market potential for intermodal transport in a region or a country. The model then decides the modal split between all-road and intermodal transport, which load units to use and which train table to use. This can be analysed to show, for example, the maximum pre- and post-haulage distance that can be supported, environmental emissions, why some locations cannot use intermodal transport, etc. The model is flexible and can be used to test different suggested system layouts, conduct sensitivity analyses, and to test the effect of the intermodal transport system on specific factors, e.g. changes in taxes, regulations or infrastructure investments. The model is useful for both large scale national transport systems and small individual transport systems. The geographical level of detail is decided by the user in the input data and could be anything from very detailed addresses to regions, all depending on the availability of input data and questions the model should answer. Similarly, the model can be used to model the transport system for a single day or to run long term systems covering several months or even years. This is controlled by the input data which can be freely varied over time, i.e. the input for day one must not necessarily be the same as the input for day two.

It should be noted that the model always works on a detailed level with exact timetables, volumes, transport times etc. This level of detail is needed, even if the intended level of analysis is strategic, to make a realistic representation of the transport system. However, care must be taken not to make a more detailed analysis of the output data than the quality of the input data used can support. Even if the HIT-model always gives very detailed output, it might not be appropriate to analyse the output on that level.

1.3 What is heuristics?

The HIT-model is a heuristic model. Heuristic models are based around a number of principles, or rules of thumb, that are used to meet the objective of the model. A heuristic model is more flexible and faster than a traditional mathematical optimisation model. When the words optimisation, optimum etc. are used in this manual, they should be interpreted as the best heuristics solution according to the principle described in the manual entitled “Heuristics”.

1.4 Basic heuristics

The full heuristics will be presented in this manual. However, a simplified description of the heuristics is included here in the beginning to facilitate the reader's understanding. Note that this description is simplified and does not cover all the functions of the model.

The model starts by assuming that all demand for transport is sent by all-road transport, i.e. by lorries only from origin to destination, and calculates the cost of all-road transport. The demand for transport is input as an amount of freight to be sent between two locations at a given time. The model then calculates, for each input demand for transport, the potential cost savings if this demand is sent by intermodal transport. When calculating the transport costs, the model also decides which (of the allowed) type of lorry will provide the lowest transport cost. The demand for transport is then sorted according to the potential cost saving, starting with the demand for the highest potential cost

saving. As the intermodal system has not yet been designed in detail, these cost savings will be based on average transport costs in the intermodal transport system. The cost savings might also be negative. Note that these cost savings are only used to sort the demand, and not to calculate the exact transport costs. The model also calculates which of the train departures the demand can use and still fulfil the time constraints, i.e. deliver no later than all-road transport, given time windows and other user constraint settings.

The model then starts with the highest ranked demand and checks if there is available capacity on one of the allowed train departures for the demand. If yes, then the demand is assigned to intermodal transport and that train. If no, the model checks if it is possible to add more capacity to the train departure. This is done by checking if the potential cost savings are greater than the cost of adding more rail capacity. The model considers that it is more expensive to start up a new rail service than to add a rail wagon to an existing train. The model also considers that any new rail capacity must be financed for the entire train loop, i.e. if a new rail wagon is added to a train that is supposed to run twice a day, then the cost of that rail wagon must be paid during the entire time the train is running. This means that the cost of adding more rail capacity might require the combined cost savings of several load units on several departures on the train in order to be able to “pay” for the new capacity. The HIT-model considers this and that each load unit often has several train departures to choose from. No new rail capacity is added until the cost saving is higher than the cost (unless any user setting has been made to allow load units with a negative cost saving to be sent by intermodal transport). The model continues to try to send the demand by intermodal transport until all demands have been tried. The demand that has not been sent by intermodal transport is sent by all-road transport. During the heuristic process, the model also considers any special user settings that have been made.

1.5 Definition of Terms and Concepts

Some terms and concepts used in the HIT-model needs to be defined.

1.5.1 All-road transport

The traditional road transport system.

1.5.2 Combined transport

Intermodal transport, where the major part of the journey is by rail, inland waterways or sea, and any initial and/or final leg carried out by road is as short as possible.

1.5.3 Demand point

A geographical location that has a demand for transport, e.g. a municipality.

1.5.4 Demand occurrence

The amount of goods to be transported from demand point A to demand point B at a given time. The demand points are the origin and destination of the goods. The time is the time when the goods is ready to be dispatched.

1.5.5 Intermodal transport

The movement of goods in one and the same loading unit or vehicle which uses two or more modes of transport successively, without handling the goods themselves when changing modes.

1.5.6 Intermodal terminal

A transshipment centre where goods are transferred between different modes of transport, e.g. from rail transport to road transport. A terminal normally also contains storage facilities for ITUs waiting to be picked up by means of the next mode, e.g. waiting for the next train to arrive at the terminal.

1.5.7 ITU

Intermodal Transport Unit (ITU). Containers, swap bodies and semi-trailers suitable for intermodal transport. Also known as load carrier, load(ing) unit or unit load.

1.5.8 Transport link

The connection from A to B, i.e. the origin and the destination for the demand occurrences. Note that A to B and B to A are two different transport links. There can be several demand occurrences on a transport link. See Figure 1.

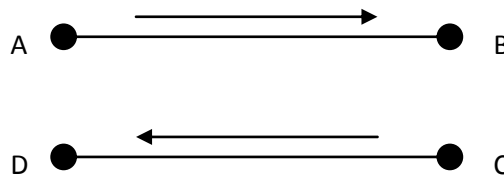

Figure 1 Transport link A to B and transport link C to D

1.5.9 Train route

The connection between two intermodal transport terminals, e.g. from terminal X to terminal Y and from terminal Y to terminal X. Note that X to Y and Y to X are the same train route. See Figure 2.

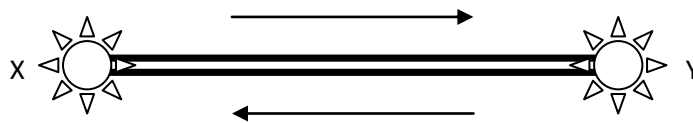

Figure 2 Train route XY

1.5.10 Train loop

A train loop is the movement of a physical train, e.g. depart X at time 1, arrive Y at time 2, depart Y at time 3, arrive X at time 4, etc. See Figure 3. There can be several train loops on one train route and one train loop can operate on several train routes. A train loop must consist of at least one train departure, but, normally, consists of several train departures. A train departure is the departure of the train from a terminal at a certain point in time.

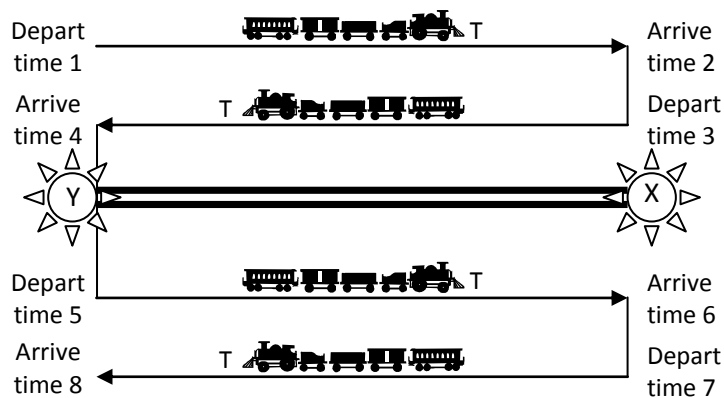

Figure 3 Train loop T

1.5.11 Transshipment

See terminal handling.

1.5.12 Terminal

See Intermodal terminal.

1.5.13 Terminal handling

Activities performed at an intermodal terminal to transfer an ITU between different modes.

2 Heuristics

The model heuristics explain the way the calculations work. The heuristics will first be explained in the text with a simplified flow chart. The simplified flow chart is also shown in chapter 4 and the full flow chart is shown in chapter 5. This is then followed by a calculated example of the heuristics. The focus here is on the heuristics used in the calculations, and this should not be interpreted as an exact flow chart of how the computer program technically operates. Naturally, the computer program follows the calculation heuristics, but the intention here is not to give a detailed description of the programming techniques used.

2.1 Jensen principles

The heuristics are based on a principle developed by Jensen (1990). The principle is based on the change in costs caused by an increased market share of intermodal transport, i.e. a transfer of goods from door-to-door road transport to intermodal transport, starting by transferring the goods with the largest cost savings. The focus is on the change of the total system cost incurred by the system. This creates an initially growing, and decreasing cost savings function of the modal transferred freight volume. The increasing costs for the rail system (including terminals) form an increasing function of the transferred freight volume. The function will have discrete jumps representing the large fixed cost where, for example, an extra train is used. The principle calculates the sum of the differences between the cost increase in the rail system (K_1) subtracted by the cost savings in the road system (K_2) for all train routes, and then subtracts the sum of the cost increase for all intermodal transport terminals, since one terminal may be used by several train routes. Note that the road system includes both the all-road transport system and the road transport element of the intermodal transport system. The largest cost savings will be found at the objective function's maximum point (X_1) and the largest transfer of freight, with no increase in system cost, will be found where the objective function ($K_2 - K_1$) equals zero from the positive side (X_2).

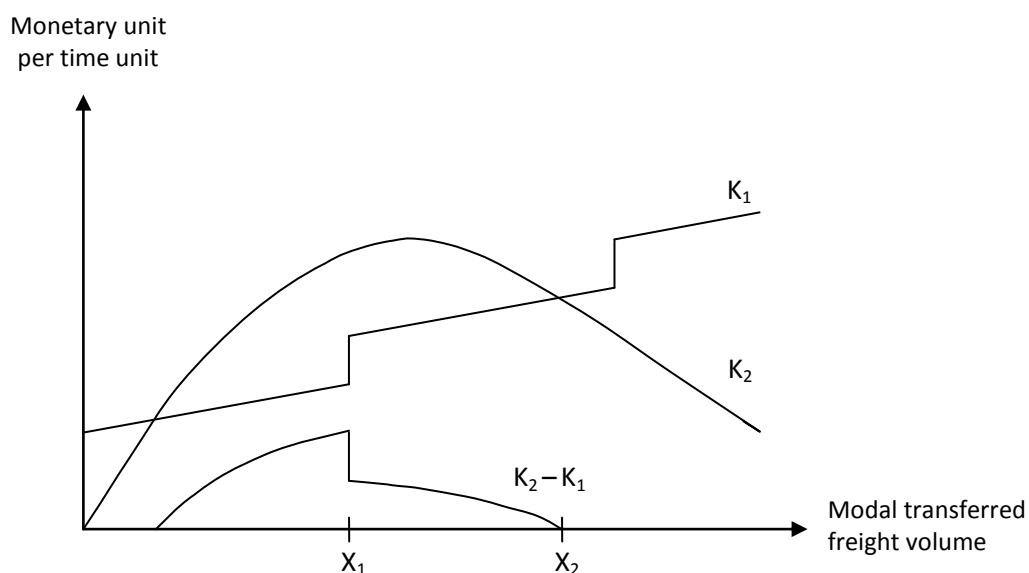

Figure 4 The cost functions (Jensen, 1990).

2.2 The HIT-model

The model heuristics in the HIT-model are built around four main components (see Figure 5). First, the data is loaded into the model from text files generated by the user interface in Microsoft Access and some preparatory calculations are made. This is then followed by the modal choice calculations in order to find the lowest cost transport system. If selected, the model continues to calculate the transport system, which transfers the most weight to intermodal transport. Finally, the data output files are written.

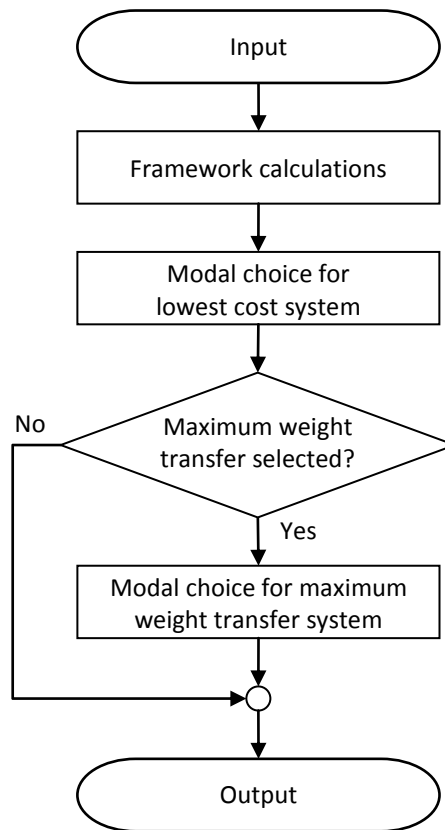

Figure 5 The main building blocks of the model heuristics

2.3 Framework calculations

After loading the input data, the heuristics start by looking at each demand occurrence (origin, destination, time ready for transport, weight). The best all-road transport lorry, and number of lorries needed, is determined by calculating the transport cost for all types of allowed lorries. The lorry type that gives the lowest transport cost is then selected. Note that it is assumed that the entire demand occurrence should use the same type of lorry, and it is the total cost for all lorries used to transport the demand occurrence that decides the best lorry type, i.e. the summary of all lorries needed for the transport. An integer number of lorries are used, i.e. if the capacity of 1.2 lorries is needed, then 2 lorries are used. In the same way, the best intermodal transport lorry is selected for the same demand occurrence using road, terminal and rail costs for the lorries¹. Note that the

¹ Note that cost calculations for the rail system here are only relative to compare the lorries. Fixed costs and costs to add new train capacity are not considered. The rail costs used are the costs for the first train to depart after the lorry has arrived at the terminal. The model might later select another train, possibly with other costs, for the lorry. However, only the variable costs for using an existing rail car are used, which are very small and only expected to vary very marginally. A complete cost calculation is made later in the model.

selection of the lorry type also includes the ITUs to be used, as they are included in the lorry type. The heuristics then continue by checking the delivery time constraints, i.e. that the delivery time for intermodal transport should match or outperform the delivery time for all-road transport. This is done by making a list of the possible train departures that this demand occurrence can use without violating the time constraint. The possible train departures are the train departures input into the input data, from which the model can choose.

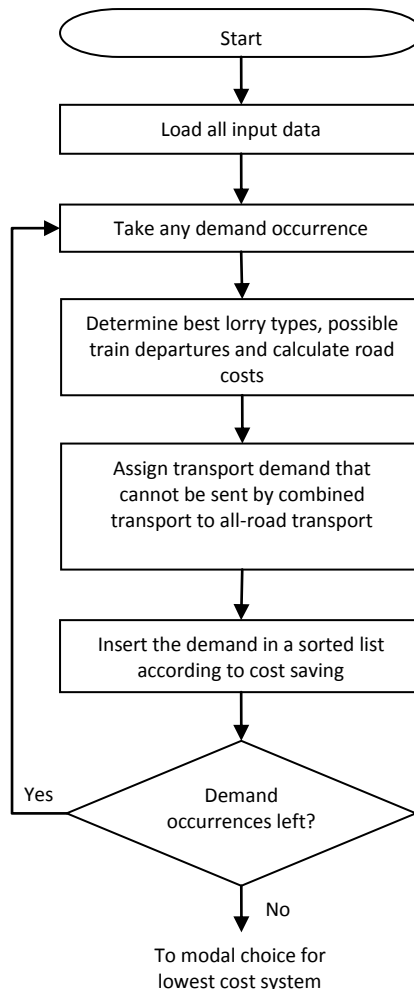

Figure 6 Framework calculations heuristics

This is done by calculating the delivery time for the demand occurrence as it was sent by each train departure. At the same time, the departure time from the shipper to meet the train is calculated². The heuristics start with the train first, scheduling it to depart after the lorry has arrived at the terminal, and continues to check train departures forward and backwards in time until the delivery time constraints are violated. See chapter 3 on the use of time periods and possible constraints³. This gives a list of the train departures that this demand occurrence is allowed to use. The list is saved for each demand occurrence.

² The departure time which is the latest that the goods can depart from the shipper and still make it in time for the train.

³ Each train loop is only allowed to be used once for each demand occurrence due to the waiting list system used in the heuristics, see chapter 2.4.1. This is not expected to impose any noticeable restrictions, since it would require extreme settings for a train to meet the delivery time criteria on two separate departures.

When the lorry types and allowed trains have been determined for all demand occurrences, they are put on a list and sorted according to the potential cost savings in the road transport system by meter rail car needed for the demand occurrence, if it should be transferred to intermodal transport (cost of all-road transport minus the cost of the road part of intermodal transport). A comparison with the train length required by the lorry's ITUs is used, since train capacity is the most limiting and expensive resource in the system and needs to be used to its best extent. If a train route optimisation has been selected, a separate list is used for each train loop. Otherwise, a common list is used for the entire transport system. The sorted list is used to determine the order in which the demand occurrences should try to be sent by intermodal transport.

The heuristics have also checked that there are allowed train departures that can meet the demand, that the sending and receiving terminals are not the same, and that the cost savings in the road transport system have not already violated the total cost saving constraints (if the lowest cost optimisation is selected)⁴. If not, intermodal transport is not an option, and the demand occurrence is assigned to all-road transport and not inserted in the sorted list. Similarly, if no all-road lorries are allowed, then the demand occurrence is directly assigned to intermodal transport and the necessary train capacity is directly inserted⁵.

2.4 Modal Choice

In this step, the model starts with the sorted list of demand occurrences, where the first demand occurrence in the list has the best potential cost savings when sent by intermodal transport, as compared to all-road transport. The heuristics start by selecting a train route (or the entire system, if a total system optimisation is selected). The fixed cost for the train route (or system) is added to the aggregated cost and cost savings for the train route. The fixed cost for a train route represents the costs for the train route that cannot be assigned to an individual ITU, e.g. rent for a terminal. In the event that shared fixed costs are present in the intermodal transport system that cannot be allocated to individual ITUs, these costs must be considered jointly for the rail transport system, e.g. rent for a terminal. These fixed costs must be added to the aggregated transport system costs as a lump sum at the start of the model run, since the modal choice is based on the aggregated cost and cost saving. These costs are thus never allocated to individual ITUs. If several train routes use the same shared fixed resources, e.g. several train routes using the same terminal, a division of the shared fixed costs among them must be done externally in the model input. The costs must, therefore be known at the start of the model run⁶.

The sorted demand list for the train route (or system) is selected and the heuristics begin by selecting the demand occurrence that is first on the list, i.e. with the highest potential cost savings. Note that the demand occurrences are selected in order of their cost savings and not by time, geography, etc. A

⁴ The train system is always a cost. If the cost savings in the road transport system alone (all-road cost - intermodal transport road cost) cannot meet the cost constraints (normally that intermodal transport should have a lower total cost), adding more costs will only make it worse. This demand occurrence will, thus, have a negative cost saving. Note that if maximum transfer optimisation is selected, then some demand with negative cost saving can be sent. Then these demand occurrences remain in the heuristics.

⁵ This will affect and partly invalidate the modal choice heuristics.

⁶ If the model output should result in that no intermodal transport is used on a train route where a fixed terminal cost is inserted, a new allocation of the fixed costs should be done and the model re-run with the fixed costs removed for that train route and no intermodal transport allowed for the train route.

demand for the last train departure can, for example, be selected before a demand for the first train departure.

The modal choice is done differently when searching for the lowest cost system (X_1 in Figure 4), or the maximum transport of goods without an increase in total cost (X_2 in Figure 4). The model first follows the same heuristics until the lowest cost system is found. The model then changes the heuristics if the maximum transfer is selected.

2.4.1 Lowest Cost System

The heuristics take the selected demand occurrence and first checks if there is available capacity, i.e. already added rail cars that would be empty at the time of departure⁷, for at least one of its lorries on any of the allowed trains for the demand. If so, the train is loaded, and, if necessary, the demand occurrence is split. Splitting means that the demand that can be loaded is transferred to its own demand occurrence and loaded onto the train, while the remaining demand stays in the selected demand occurrence and continues in the heuristics process. If the entire demand occurrence has been loaded, the next instance on the list is selected.

If something remains of the demand occurrence, the heuristics continue by determining whether any new train capacity should be added to carry the demand. The heuristics try to add the train capacity that has the lowest cost. The allowed train departures for the demand occurrence are therefore sorted according to the cost of adding the capacity for one more lorry on the train loop (including if a new train is required, or only new rail cars). Note that the cost is for the entire train loop, since each train loop is assumed to consist of the same train set for the duration of the entire loop. Any new rail car added to the train loop will thus run the entire train loop and be available for all departures on the train loop. When searching for the transport system with the lowest cost, train capacity cannot be used that has not been fully “financed” i.e. does not provide positive cost savings. It is therefore necessary to consider the cost savings jointly for the entire loop when deciding to add new capacity. It is likely that several demand occurrences will be needed to meet the economic requirements of adding new capacity, e.g. when a new train is needed. The cost savings generated by several demand occurrences (either on the current departure or on any other departure on the train loop) might then be needed to compensate for the high start-up costs of a new train. The new train should thus not be inserted on the loop until the cost is compensated by cost savings⁸ (or if another criterion is set, e.g. that intermodal transport is allowed to have a higher cost by a certain percent)⁹.

⁷ Rail cars are always inserted on the entire train loop simultaneously. Thus, they might be used on some departures, but be empty on others. The model can also be run with a given train system where the number of rail cars to use are given and inserted by the model input.

⁸ Note that the fixed costs for the terminal are not considered in this comparison. The fixed costs are only included in the aggregated costs, as it would be unrealistic to demand that a single train loop (i.e. the first to add capacity) should cover the entire fixed costs. Under extreme circumstances it could be possible for a train route to never reach a positive aggregated cost saving, i.e. curve K_2-K_1 will never reach a positive value since the fixed costs are higher than the best possible cost saving. However, this is checked by the model after the lowest cost system has been determined. The demand assigned to intermodal transport is then reassigned to all-road transport, the trains are removed and the costs are recalculated. The exception is if a fixed number of trains or least number of trains have been inserted on the train route by the input data. Since this is a given train system that should be run, it is then allowed for the maximum cost saving to be negative. This test is also not performed if a total system optimisation is selected, since all trains route are to be considered jointly then.

⁹ If two train departures are very close together, the departure that first can “finance” a locomotive will have an advantage over the other departure (i.e. lower cost as the locomotive already has been financed). This will

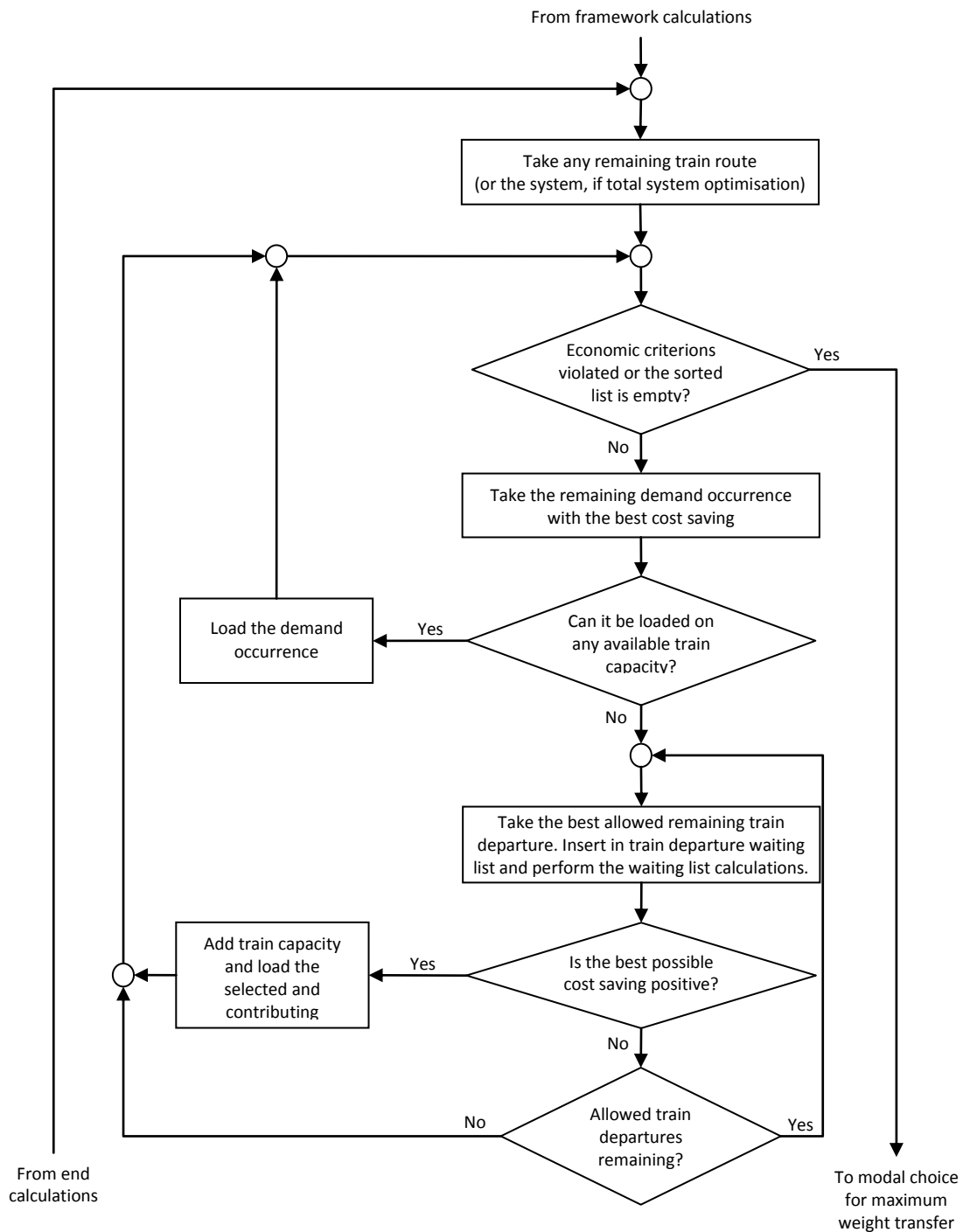

Figure 7 Lowest cost system heuristics

cause lorries to select this departure. It is therefore not recommended to input several train departures very closely together, since the selection between these train departures not necessarily will be optimal. This level of detail is also not relevant in a strategic model. It is recommended to use the function where several trains are allowed on the same departure instead.

The heuristics use a waiting list for each train departure to collect demand occurrences until new train capacity can be added. The waiting list for a train departure is simply a list of demand occurrences that can be sent with that train departure, but where the economic constraints are still violated, i.e. no capacity can be inserted. The waiting lists and cost calculations are explained in detail below. The allowed train departures are tested one by one, according to the train list sorted above¹⁰ either until the cost savings on a train departure allow enough train capacity for at least one lorry in the demand occurrence to be inserted, or all allowed departures have been tested. Naturally, the demand occurrences can be split if not enough train capacity can be financed for the entire demand occurrence. When a departure with enough cost savings is found, the corresponding train capacity is inserted and the demand occurrences are assigned to intermodal transport. If the selected demand occurrence has been split, i.e. not everything could be loaded, then the heuristics continue by checking the remaining allowed train departures for the remaining part of the demand occurrence. If a demand occurrence cannot be loaded on any train departure, it is left on the waiting lists.

The heuristics then continues by selecting the demand occurrence with the second best potential cost saving in the sorted lists above and repeats the tests above, as long as there are remaining demand occurrences. When all demand occurrences for a train route has been tested, the demand still waiting on the waiting lists are assigned to all-road transport. The next train route is then selected etc. See 0.

2.4.1.1 Waiting lists and cost calculations

The waiting lists and cost calculations require a more detailed explanation. When determining whether a new train capacity should be added, the heuristics first take the allowed train departure with the lowest cost (according to the train list sorted above). The demand occurrence is inserted at the end of the waiting list for the departure and the heuristics calculate whether the total cost savings from all waiting lists on the train loop together could “finance” a new train capacity (i.e. everything waiting at the different departures on the train loop are considered together). If not, the same demand occurrence is also inserted on the waiting list for the next train departure in the list and the calculation is repeated¹¹, etc. The same demand occurrence can thus be inserted on several waiting lists, but is removed if it is loaded on a train.

¹⁰ If several train departures have the same cost, the train to depart first after the demand has arrived at the terminal (without adjusting the departure time from the sender) is used first. This is followed by trying later departures and, after that, earlier departures. E.g. if there are allowed train departures at time 15, 18, 21 and 24 and the demand arrives at the terminal at time 20, then the departures are tested in the sequence 21, 24, 18 and 15.

¹¹ Since each demand occurrence only is allowed on one departure on each train loop, there is no risk of counting the cost saving twice.

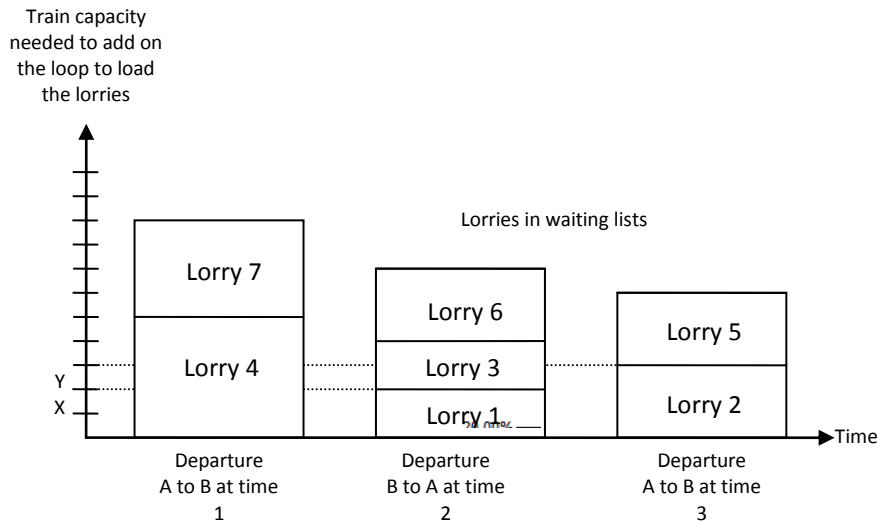

Figure 8 Waiting lists for a train loop

When calculating the cost savings on the waiting lists, the heuristics start by determining the possible train capacity that should be added. The heuristics are not allowed to split a lorry between two train loops, but a demand occurrence can be split as long as the individual lorries stay intact. The ITUs on a lorry are thus kept together. Train capacity can therefore only be added to the train loop in multiples of lorry lengths. The possible train lengths are thus at the end of each lorry on the waiting lists. Figure 8 shows an example of a train loop with three departures and their waiting lists. The x-axis is the different departures, and the y-axis is the train capacity (i.e. rail car length) required for the lorries on the waiting list. The smallest train capacity that can be added is the capacity for the lorry 1, i.e. capacity X. The next train capacity that one can add is capacity Y, i.e. the length of lorry 2. The cost savings in the road transport system¹² from lorry 1 are thus compared with the costs of adding a train with capacity X to the entire loop and sending the lorry with intermodal transport¹³. This gives the cost savings for adding train capacity X. Next, the intermodal cost savings from lorry 1 and 2 (which are the lorries that can be loaded on capacity Y) are compared with the cost to add train capacity Y, which gives the cost savings for adding train capacity Y, etc. This continues by testing to add train capacity for each of the remaining lorries on the waiting list, either until all the lorries have been tested or the cost saving in the road transport system for all remaining lorries on the waiting list is negative¹⁴. The highest of the calculated cost savings from the waiting list (i.e. the cost savings, if adding train capacity X or Y, etc.) is selected and, if the cost savings are positive¹⁵, the associated train capacity is inserted and the lorries are sent by intermodal transport. If necessary, the demand occurrences are split. The heuristics then continue to test the remaining allowed train departures if the best cost saving was negative; if nothing was transferred to intermodal transport, or if the selected demand occurrence from the sorted list was split, i.e. something of the demand occurrence remains to be tested.

¹² Cost saving in direct road when transferring the demand to intermodal transport minus cost for the road transport part of intermodal transport.

¹³ Terminal handling costs for the ITUs and the costs to use a rail car.

¹⁴ If the cost saving in the road system already is negative, then adding more costs from the rail system cannot make the total cost saving positive.

¹⁵ If the cost control parameter is used, i.e. if intermodal transport should have a X% lower or higher cost compare with direct road transport to be selected, this means that the cost saving must be higher than X% of the costs of transporting by direct road transport. Note that X might be negative, thus allowing demand with a negative cost saving to be transferred to intermodal transport. During the calculations for the lowest cost system, this comparison is made for each waiting list.

2.4.2 Maximum Weight Transfer

When searching for the transport system with the maximum transfer of goods¹⁶ to intermodal transport without an increase in total system cost (X_2 in Figure 4), there is also a possibility to transfer goods with a negative cost saving to intermodal transport, since the negative cost saving of this demand is compensated for by the positive cost saving of previously transferred demand. The heuristics follow the same heuristics as for the lowest cost optimisation above, until the lowest cost system is reached (but naturally without assigning all remaining demand to all-road transport). This is to ensure that all demand with a positive cost saving is transferred before attempting to transfer the demand with a negative cost saving. The heuristics used when searching for the lowest cost system cannot be used, since the cost savings will never turn positive, and thus there is no clear sign to determine when some demand on the waiting list should be transferred to intermodal transport. The heuristics will therefore focus on adding train capacity to the train loop, which will cause the smallest negative cost saving.

After the lowest cost system has been determined, the heuristics starts by selecting a train route (or the entire system, if a total system optimisation is selected) and transferring all demand from the sorted demand list to the waiting lists for the train departures (but without trying to insert any train capacity). The heuristics then determine the train loop with the lowest negative cost saving for adding goods to the train loop, and adds train capacity and goods to that train loop.

This is done for each train loop, calculating the total cost of transferring the first lorry on the waiting list for all departures on the train loop to intermodal transport (including the cost to add new train capacity). However, as not all lorries are of equal length, the train capacity for the longest of the first lorries on the waiting lists is selected¹⁷. The exception is if a new train would be required to load the longest lorry, while it would be possible to add the shorter lorries without a new train. The heuristics try to avoid the high start-up costs of a new train and, therefore, only allow a new train to be added if no more lorries can be added to the previous train¹⁸.

¹⁶ Transfer of goods is here represented by number of lorries (or more exactly the length of the ITUs, since the lorries are sorted according to cost saving per meter rail car used in the previous steps) transferred to intermodal transport. The model does not consider the weight loaded on each ITU during the modal choice. However, the weight loaded on individual ITUs is not expected to vary significantly. The interest in searching for maximum transfer of goods lies mainly in environmental aspects which largely depends on the number of lorries used, rather than the exact weight loaded on them.

¹⁷ This means that several of a shorter ITU can be loaded if there is a large length difference. I.e. if the lorry for departure A is 10 length units long and the lorry for departure B is 20 length units, then train capacity for 20 length units is selected and (if the next lorry in the waiting list also is 10 length units) two of the shorter lorries from departure A are loaded.

¹⁸ Assume that, for example, train capacity enough for a short ITU can be added to a train without requiring a new train. There are both short and long ITUs (which cannot fit on the train) standing first in the waiting lists for the departures on the trail loop. The heuristics then only considers the short ITUs. A new train is not allowed to be added until the short ITUs have been assigned to intermodal transport, i.e. the train has been fully utilised. Otherwise, the high cost of a new train required for the long ITUs might prevent the short ITUs from being sent by intermodal transport.

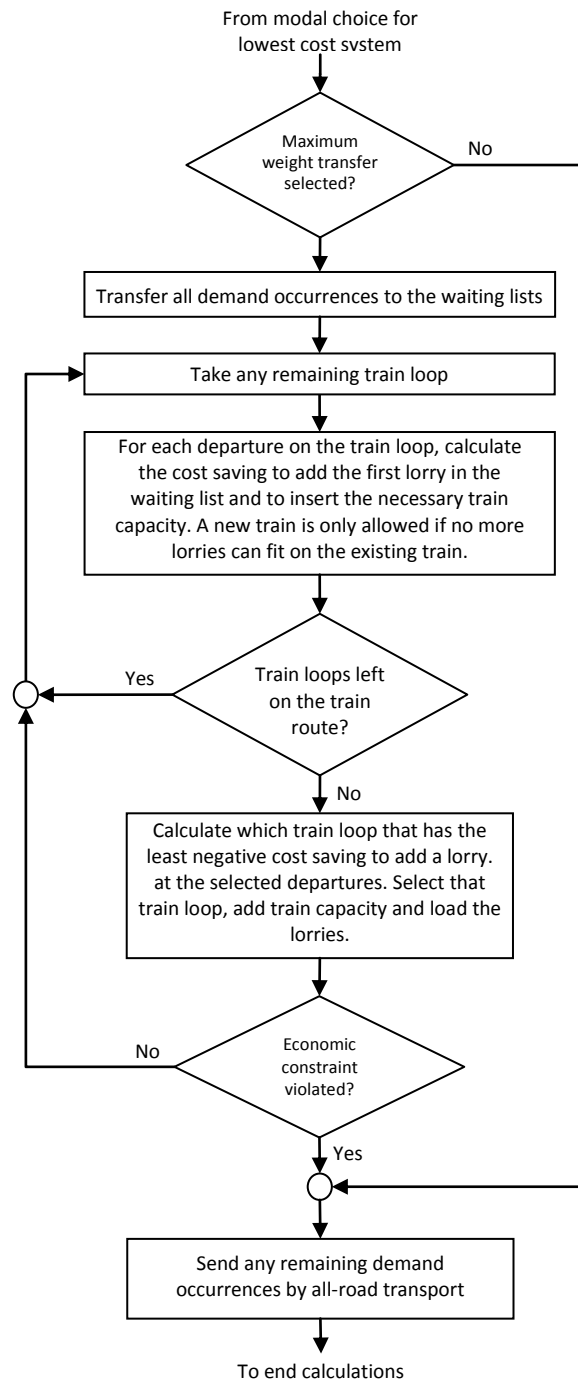

Figure 9 Maximum weight transfer heuristics

These calculations are repeated for all train loops on the train route, and the train loop with the least negative cost savings per rail car meter is selected. The first lorries on the selected train loop are then assigned to intermodal transport and train capacity is added. If necessary, the demand occurrences are split. This maximum weight transfer heuristics are repeated until the economic constraints (while considering the control parameters¹⁹ and other constraints) are violated, i.e. the

¹⁹ The cost control parameter allows X% difference of the total aggregated cost from the cost if all demand had been sent by direct road.

aggregated cost savings are zero for the train route (or system)²⁰. Any remaining demand occurrences on the waiting lists are then assigned to all-road transport. See Figure 9.

2.5 End Calculations and Output

If train route calculations have been selected, then the model checks if there are any train routes left that have not been tested. If so, the model then selects the next train route and returns to the lowest cost calculations. If not, the output files are written and the model run ends. See Figure 10.

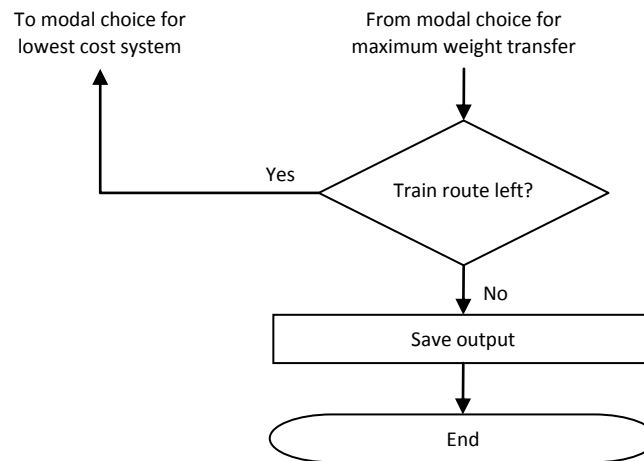

Figure 10 End calculation heuristics

2.6 A Calculated Example

A simplified calculation example might clarify the heuristics. The calculation data have been adjusted to give a simplified example that highlights the basic heuristics. All numbers are fictitious.

Assume a transport system consisting of a large number of demand occurrences and train loops. This example will focus on two of the demand occurrences. Demand occurrence D consists of 50 tonnes and demand occurrence E consists of 40 tonnes. They both occur at the same time and should be sent to the same destination; however, the demand occurrences are completely separate and are not transported together. Both demand occurrences have the same all-road transport distance to the receiving destination and the distance to and from the terminals is also the same. Both use the same train route and there are two alternative train departures they both can use (departures N and M). There are also two types of lorries to choose between. Type A is a trailer lorry with one ITU (i.e. the trailer) and can load 20 tonnes. Type B is a swap body lorry with two swap bodies (i.e. two ITUs) and can load 25 tonnes. The same types of lorries are used for both intermodal transport and all-road transport. The cost for both lorry types is 100 for the transport to and from the terminals (25 for one transport leg and 75 for the other) and 300 for the all-road transport. Both lorry types take up the same capacity on the train. The cost to handle one ITU at the terminals is 50 (20 at one terminal and 30 at the other) and the variable train cost to transport an ITU is 5 for a swap body and 10 for a

²⁰ The cost saving will never be exactly zero, since the heuristics uses integer lorries. In many cases, the heuristics will also stop adding capacity when a new train is needed, since the large extra cost of a new train will push the aggregated cost saving past zero. This will cause the aggregated cost saving to stop a bit above zero. Also, sometimes there might just not be enough goods that could be transferred to intermodal transport due to time constraints.

trailer. The cost to insert train capacity on the train loop for one trailer (or two swap bodies) is 500. See Figure 11 and Figure 12.

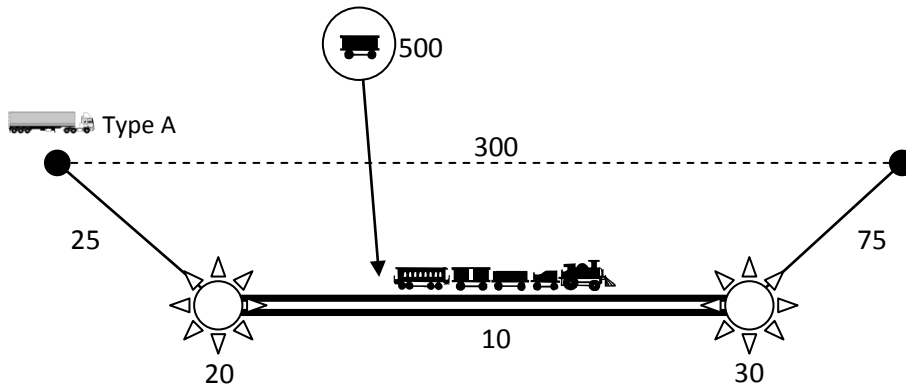

Figure 11 Costs for lorry type A

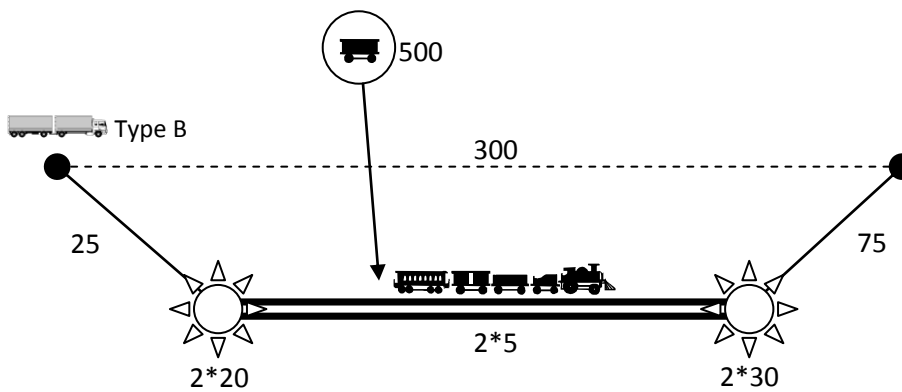

Figure 12 Costs for lorry type B

First, the best type of lorry is determined. Demand occurrence D can either use 3 lorries of type A ($50/20 = 2.5 = 3$ lorries) or 2 lorries of type B. The cost for transport to and from the terminals is thus $3 \cdot (25+75) = 300$ for lorry type A and $2 \cdot (25+75) = 200$ for lorry type B. However, lorry B consists of 2 ITU and thus costs $2 \cdot 2 \cdot (20+30) = 200$ at the terminal and $2 \cdot 2 \cdot 5 = 20$ for the train transport, which provides a total cost of 420. The same cost for lorry A is $300 + 3 \cdot 1 \cdot (20+30) + 3 \cdot 10 = 480$. The best lorry for intermodal transport is thus lorry type B. This is compared to the cost of an all-road transport for a demand occurrence to determine the potential cost savings. There are two alternative lorries for the all-road transport. In this example, the all-road lorries are identical to the intermodal transport lorries. The all-road transport cost is 300 for each lorry, i.e. $3 \cdot 300 = 900$ for lorry type A and $2 \cdot 300 = 600$ for lorry type B. The best lorry type for all-road transport is thus lorry type B. The potential cost savings for demand occurrence D are $600 - 420 = 180$, i.e. the cost difference between the best alternative in intermodal transport and in all-road transport. The calculations are summarised in Table 1 and Table 2.

The same calculation for demand occurrence E in intermodal transport is 2 lorries and $2 \cdot (25+75) + 2 \cdot 1 \cdot (20+30) + 2 \cdot 10 = 320$ cost for lorry type A. For lorry type B, 2 lorries are used and the cost is $2 \cdot (25+75) + 2 \cdot 2 \cdot (20+30) + 2 \cdot 2 \cdot 5 = 420$. Lorry A is thus the best alternative for intermodal transport. The all-road transport cost for both lorry type A and B is $2 \cdot 300 = 600$. Any of the lorry

types can thus be selected for all-road transport. The potential cost savings for demand occurrence E is $600-320 = 280$. These calculations are performed for all demand occurrences in the system. The intermodal transport lorries selected are thus 2 swap body lorries of type B with a potential cost saving of 180 for demand D, and 2 trailer lorries of type A, with a potential cost saving of 280 for demand E.

Lorry type A, trailer					
Lorry data		Activity	Cost per ITU	Cost per lorry	Total cost
Demand	50 tonnes	Road transport to terminal	-	25	$3*25=75$
Loading capacity	20 tonnes	Terminal handling one	20	$1*20=20$	$3*20=60$
Number of lorries	$50/20=2.5$ →3 lorries	Rail transport	10	$1*10=10$	$3*10=30$
Number of ITUs per lorry	1	Terminal handling two	30	$1*30=30$	$3*30=90$
		Road transport from terminal	-	75	$3*75=225$
		<i>Sum intermodal transport</i>	-	160	480
		All-road transport	-	300	$3*300=900$

Table 1 Calculations for demand occurrence D and lorry type A

Lorry type B, swap body					
Lorry data		Activity	Cost per ITU	Cost per lorry	Total cost
Demand	50 tonnes	Road transport to terminal	-	25	$2*25=50$
Loading capacity	25 tonnes	Terminal handling one	20	$2*20=40$	$2*40=80$
Number of lorries	$50/25=2$	Rail transport	5	$2*5=10$	$2*10=20$
Number of ITUs per lorry	2	Terminal handling two	30	$2*30=60$	$2*60=120$
		Road transport from terminal	-	75	$2*75=150$
		<i>Sum intermodal transport</i>	-	210	420
		All-road transport	-	300	$2*300=600$

Table 2 Calculations for demand occurrence D and lorry type B

Next, the lorries should try to be sent by intermodal transport. The demand occurrence with the highest potential cost saving compared to necessary train capacity (all lorries take up equal train capacity in this example) is demand occurrence E. This demand occurrence is therefore selected first.

Departure N is tested first. Since previously²¹, there was already a train and some rail cars inserted on the train loop. There is enough capacity available for one trailer on the departure. One of the two trailers in the demand occurrence is then assigned to the train. It is then calculated whether any new train capacity can be inserted on the train loop for the other trailer. The cost of inserting new capacity equal to one trailer (or two swap bodies) is 500, which is less than the potential cost saving. No new capacity can thus be inserted on the train loop. A copy of the remaining trailer is then put on the waiting list for the train departure (departure N), and the other possible train is tested (departure M on the next train loop). This departure has no available capacity, the waiting list is empty and the cost to insert a new capacity for one trailer is also 500. Since trains operate on closed loops, any new capacity is added to the entire train loop. This train loop consists of two departures, the current departure M and another departure K. On departure K, there is already another trailer on the waiting list with a potential cost saving of 300. Individually, the two trailers do not generate a cost saving large enough to have any new train capacity inserted, but together they generate a positive cost saving of $280+300-500 = 80$. Thus they can be sent by intermodal transport. The train capacity for one trailer is therefore added to the train loop, and the current trailer on departure M and the trailer on the waiting list for departure K are assigned to the train. Since the trailers are on two different train departures, they can both share the same new capacity on the train loop. The copy of the trailer inserted on the waiting list for departure N is deleted.

²¹ In this example, the transport system consists of a large number of demand occurrences. Some of them has a higher potential cost saving than the studied occurrences D and E and has, thus, already been tested if they can be sent by intermodal transport.

3 Time

Time has become an increasingly important factor in the transport industry. An important factor for this is the increasingly streamlined and centralized production and warehousing in the industry today. However, the focus on time is not always on pure optimisation (e.g. the faster the transport, the better), but rather on meeting a basic set of criteria. The survey by Saxin, Lammgård and Flodén shows that on-time deliveries are ranked as the most important factor of 33 factors when selecting transport company. In another question in the survey, 17% of the decision when selecting a transport company was attributed to on-time deliveries and 21% to the transport time. Thus, 38% of the weight was time related. However, the importance of on-time deliveries should not be confused with a need for faster transport. The transport company often has an agreed time window within which the delivery should be made, e.g. between 9 a.m. and 9.30 a.m., or sometime during the day. The time windows can vary greatly in length. Short time windows often create planning and capacity constraints when receiving the goods, e.g. a limited number of loading docks and personnel, where the important aspect is the on-time delivery and not the transport time. It is, thus, important to know exactly when the goods will arrive, but less important if it is e.g. in the morning or in the afternoon²². Thus, there is a difference between the agreed delivery time window and the greater potential time window in which the delivery time window can be placed, e.g. the delivery should be made sometime during the next day (potential time window) and it is agreed that it will be delivered between 9.00 and 9.30 (delivery time window). The agreed delivery time window is a matter of negotiation between the transport company and receiving company. From a modelling perspective, it is the greater potential time period that is of real interest. Technically, both all-road transport and intermodal transport as the possibility to meet an agreed delivery time window.

There is also a difference between delivery times (i.e. when the goods are delivered to the receiver) and transport times (i.e. the time needed to perform the actual transport) that is very important to include in the modal choice in the model. An overnight transport might, for example, arrive at the receiver at 4 a.m., but if the receiving company is closed and cannot receive the shipment until 8 a.m., then the delivery time must be regarded as 8 a.m. This is particularly important when comparing road transport and intermodal transport in Sweden, since much of the competition occurs on overnight transport. The often-longer transport times in intermodal transport, compared to all-road transport, can be absorbed here by the later delivery times.

As previously shown, one of the modal choice criteria is that intermodal transport must match or outperform the delivery times in all-road transport. The comparison is thus relative to all-road transport. However, as shown above, a comparison between the delivery times cannot be made directly minute by minute, as it is not normally so that a transport that is, for example, five minutes faster is significantly better. A later delivery by intermodal transport is, thus, not necessarily a delay, but can in many cases be regarded as an equivalent delivery time. Three alternative modelling methods will be used to represent this: delivery time windows, time overlap or comparative delivery time gaps. The methods can be used individually or simultaneously.

²² Naturally, there are goods flows where the exact delivery time is important, e.g. in JIT-flows for the car industry.

3.1 Delivery Time Windows

Delivery times will be compared using user-defined delivery time windows for each transport relation. A time window is a certain time period, e.g. from 8 am to 10 am. User-defined means that it is set by the model user in the input data. This means that if intermodal transport can deliver a shipment in the same time windows as all-road transport, then the transport modes are considered to have equivalent delivery times. As the modal choice requires intermodal transport to match or outperform all-road transport, intermodal transport is also allowed to arrive in a previous time period²³. In Figure 13, both all-road transport and intermodal transport can deliver the shipment within the same time window. Road transport delivers first, but intermodal transport also delivers before the end of the time periods. Thus, both modes have equivalent delivery times for the shipment and the modal choice criteria, which requires that intermodal transport must match or outperform the delivery time by all-road transport, is met.

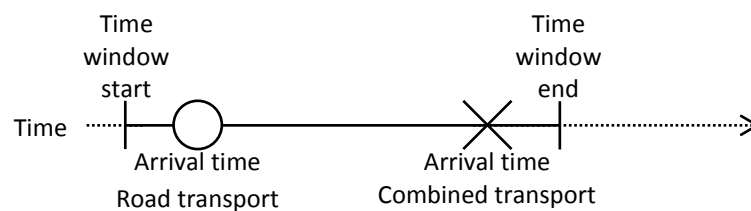

Figure 13 Delivery time windows

3.2 Time window overlap

The delivery time windows can further be set to allow an overlap between two time windows. This is done independently of the time windows above. The overlap is a period of time between two adjacent time windows that is shared between the windows. The shared overlap period is considered to belong to the one of the time windows that gives the greatest delivery or departure time window for intermodal transport²⁴. This depends on in which time period the all-road transport arrives. If all-road transport arrives in the time window before the overlap, then the overlap belongs to that time window, i.e. extending the allowed time window for intermodal transport. If all-road transport arrives inside the overlap, then the overlap belongs to the next time window, i.e. the whole next time window is allowed for intermodal transport²⁵. See Figure 14 where intermodal transport and all-road transport are considered to have equivalent delivery times.

²³ In reality, earlier delivery times could always be arranged to match later all-road delivery simply by delaying the goods at the terminal.

²⁴ This depends on in which time windows the all-road transport arrives. If all-road transport arrives in the time window before the overlap, then the overlap belongs to that time window, i.e. extending the allowed time window for intermodal transport. If all-road transport arrives inside the overlap, then the overlap belongs to the next time window, i.e. the entire next time period is allowed for intermodal transport.

²⁵ The difference by using the time overlap compared to just extending the time windows is that all-road transport arriving inside the time overlap makes the entire next time window allowed for intermodal transport, which would not have been the case if the time windows had been extended.

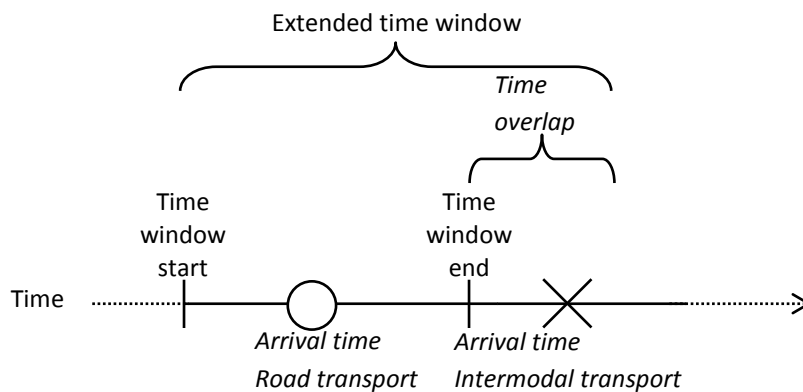

Figure 14 Time window overlap

3.3 Comparative Delivery Time Gaps

The comparative time gaps make a direct comparison between the exact delivery time by all-road transport and the delivery time by intermodal transport. If intermodal transport can deliver the shipment inside a user defined²⁶ time gap from the delivery time by all-road, then the delivery time of intermodal transport will be considered equivalent. Earlier delivery by intermodal transport is always allowed. A time gap is a certain period of time, e.g. one hour. This takes into account that the acceptance of a later delivery time probably is greater if it is only a slight difference from the delivery time of the road transport system. Figure 15 shows an example of where intermodal transport delivers within the comparative time gap and is thus considered equivalent to all-road transport.

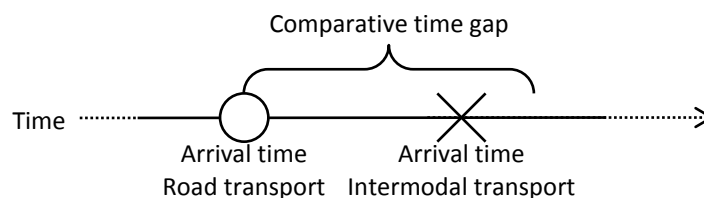

Figure 15 Comparative delivery time gaps

The comparative time gaps can also be used in combination with the delivery time windows to reduce the marginal effects when, for example, a shipment is disqualified from intermodal transport for arriving five minutes after the end of a long delivery time window, but is still only delivered slightly later than all-road transport. If both delivery time windows and comparative time gaps are used simultaneously, it is enough that one of them is satisfied for the delivery time to be considered equivalent to all road transport.

²⁶ The time gaps are set for each of the time windows used for the delivery time windows, i.e. the time window the all-road transport arrives in determines which comparative time gap to use. If only the comparative time gaps should be used, then the time windows should be shorter than the gaps used.

3.4 Departure Time Windows

Similar modelling will also be used for the departure times. The departure time for all-road transport is given by the input data, i.e. the time for the demand occurrence. However, it is unrealistic to assume that the shipper does not have any flexibility in adjusting the departure time, especially since the departure times set in the input data are most often expected to be based on average statistics²⁷. Intermodal transport is dependent on meeting the train's departure times at the terminal, and since there are usually only several departures per day, the departure time from the demand point becomes very important. The model must therefore be given some flexibility in order to adjust the departure time from the sending demand point and to match the available train departures. Departure time windows and comparative departure time gaps, similar to the time windows and gaps used when comparing delivery times, will therefore be used. The methods can be used individually or simultaneously. The time windows and gaps used are the same as for the arrival calculations.

The intermodal transport departure times from the sending demand point can be adjusted inside a user-defined departure time window. Later departure times for intermodal transport are always allowed²⁸. See Figure 16 where both intermodal transport and all-road transport have equivalent departure times.

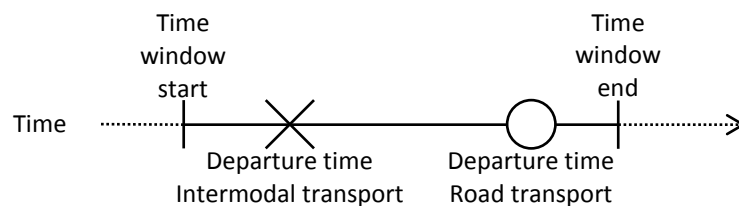

Figure 16 Departure time windows

As with the delivery time windows, a shared overlap time period between two adjacent time windows can be used. The shared overlap is considered to belong to the time periods that give the greatest time window for intermodal transport.

3.5 Comparative Departure Time Gaps

A comparative departure time gap allows intermodal transport to depart earlier than all-road transport as long as it is within the time gap. Later departure times for intermodal transport are always allowed. See Figure 17 where the model has determined that an earlier departure time for intermodal transport is more appropriate, e.g. to catch an early train at the terminal. The suggested departure time is within the allowed time gap. Thus, the suggested departure time is allowed.

²⁷ Data availability makes this the most likely option. However, the model could also be used by a transport operator or shipper with detailed flow data.

²⁸ In reality, later departure times could always be arranged to match all-road departures simply by departing the same time as all-road transport and allowing the goods to wait at the terminal.

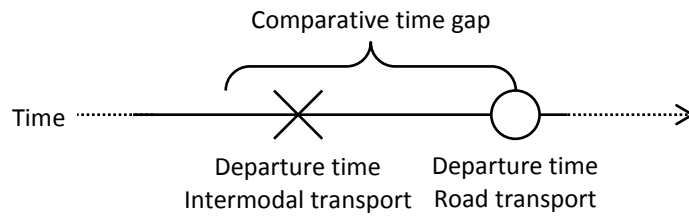

Figure 17 Comparative departure time gap

3.6 Operating window

Together, the time periods and time gaps form an allowed time window for intermodal transport in which to operate, i.e. the time window between the earliest allowed departure time and latest allowed delivery time. Two examples of operating windows using only time periods and time gaps can be seen in Figure 18.

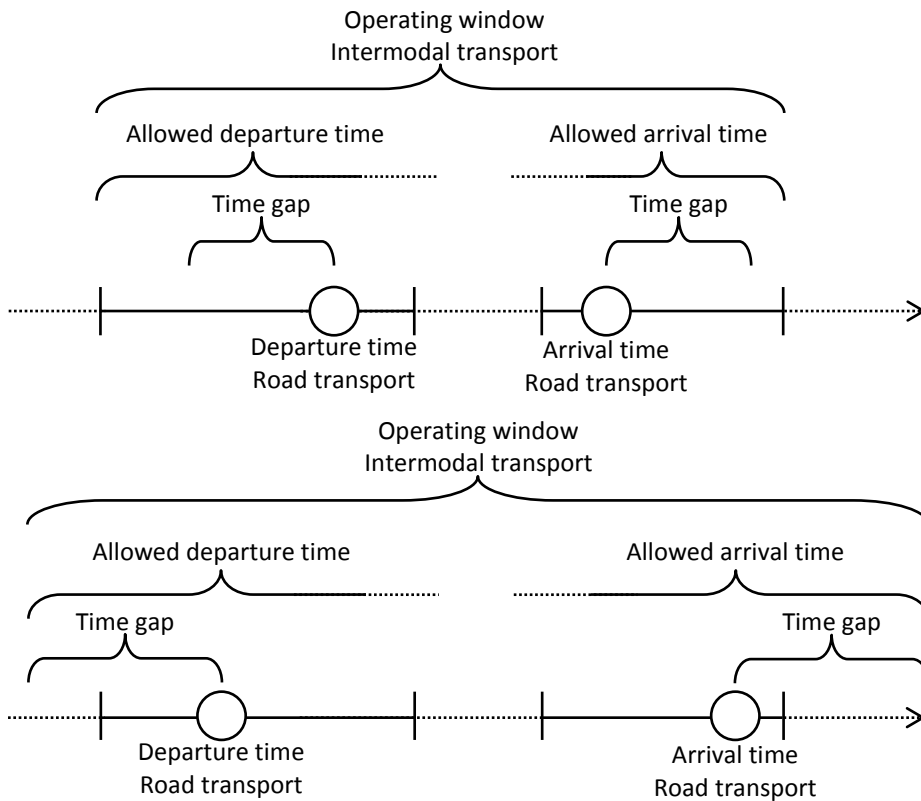

Figure 18 Examples of operating windows for intermodal transport

The figure shows both the time windows and the comparative time gaps. In the first example, the comparative time gaps are within the allowed time windows. The operating window thus follows the time windows, since they provide a more generous operating window. The time gaps will thus not affect the operating window. In the second example, the comparative time gaps stretch outside the

time windows. The time windows are then disregarded, and the operating window follows the comparative time gaps²⁹.

The time system in the model is implemented using a continuous time scale. Each demand occurrence and train departure can freely, and independently of each other, be set to any time. The time windows and time gaps can also be defined individually for each transport link and time. A decimal system is, for mathematical simplicity, used for all time measurements, e.g. 1 hour and 30 minutes are calculated as 1.5 hours. Note that the model itself does not use any running clock, continuous or discrete.

²⁹ Naturally, the selection between time windows or time gaps can be mixed, e.g. that time windows are used to set the allowed departure time and time gaps are used to set the allowed arrival time.

4 Simplified Flow Chart

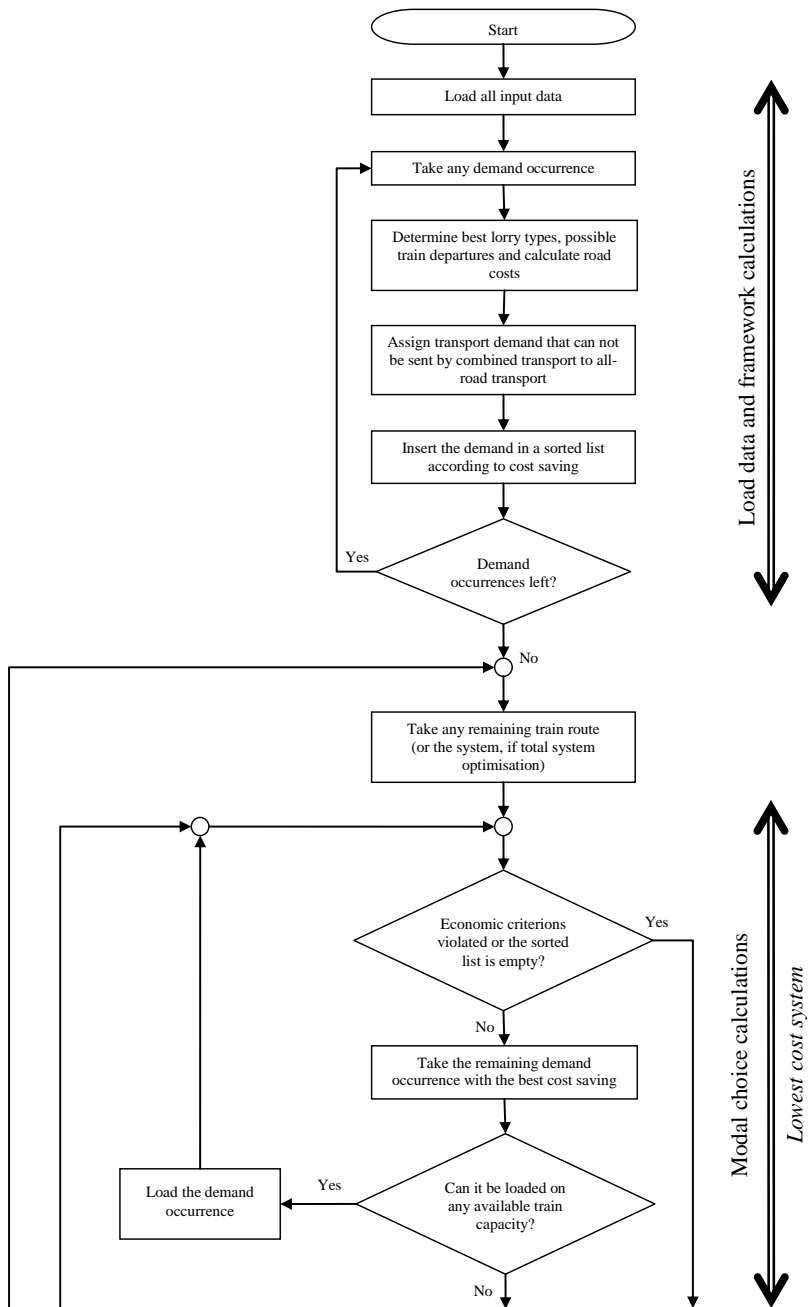

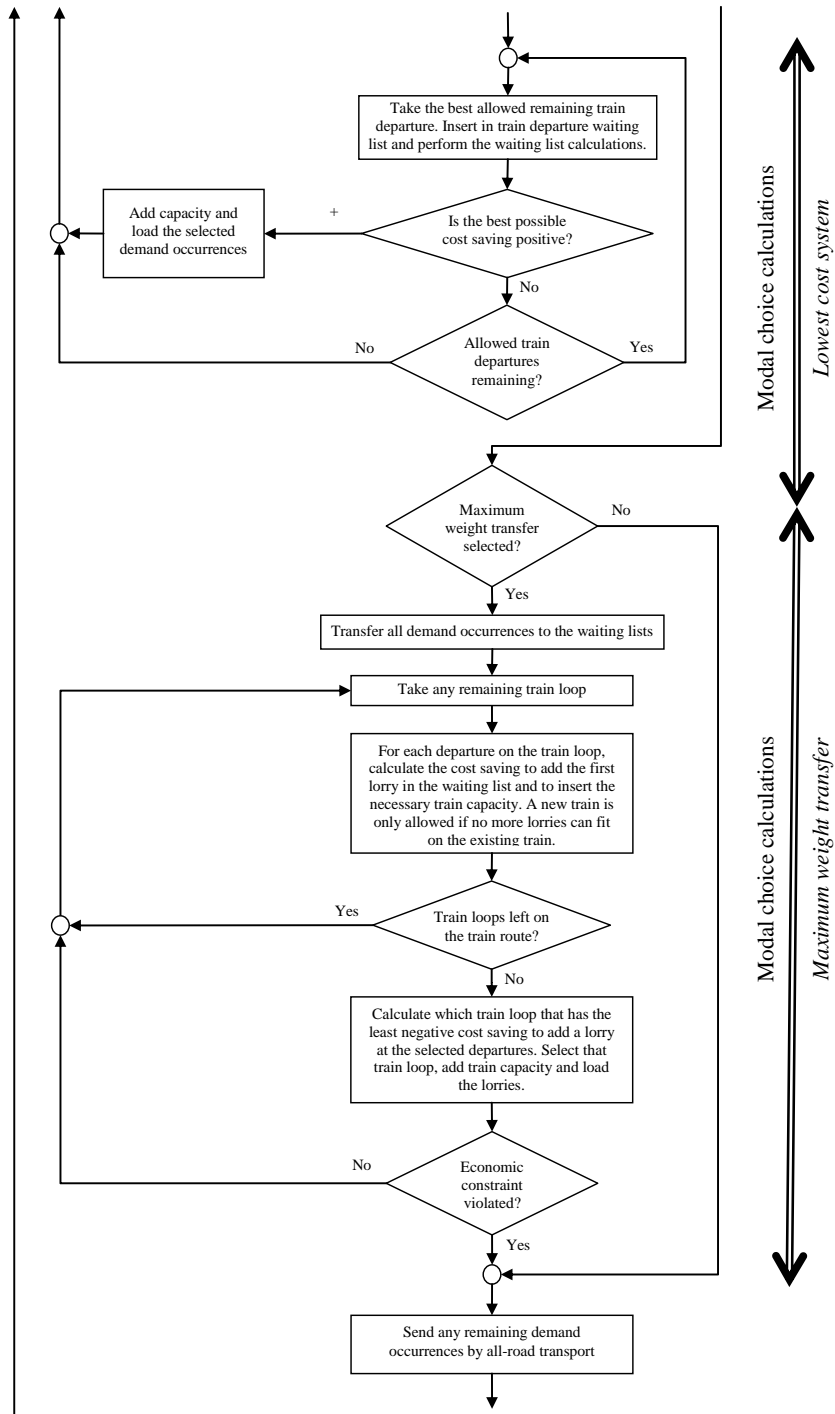

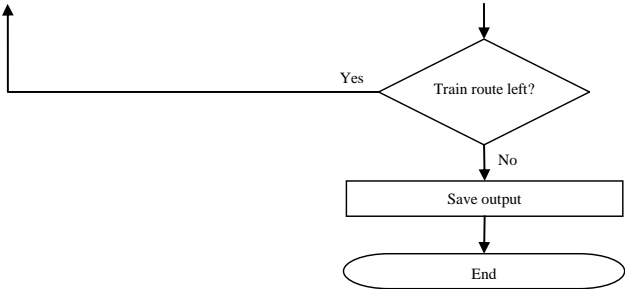

5 Detailed Flow Chart

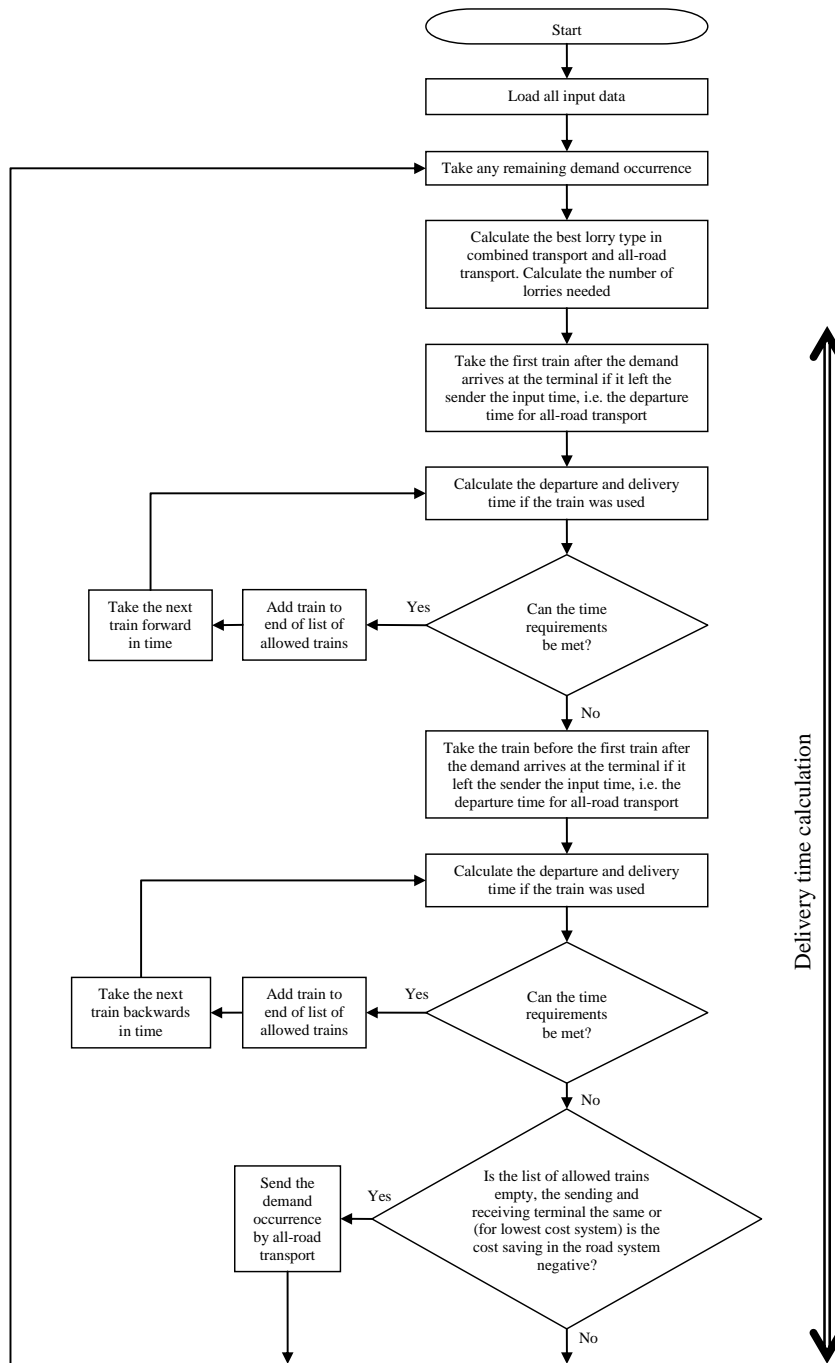

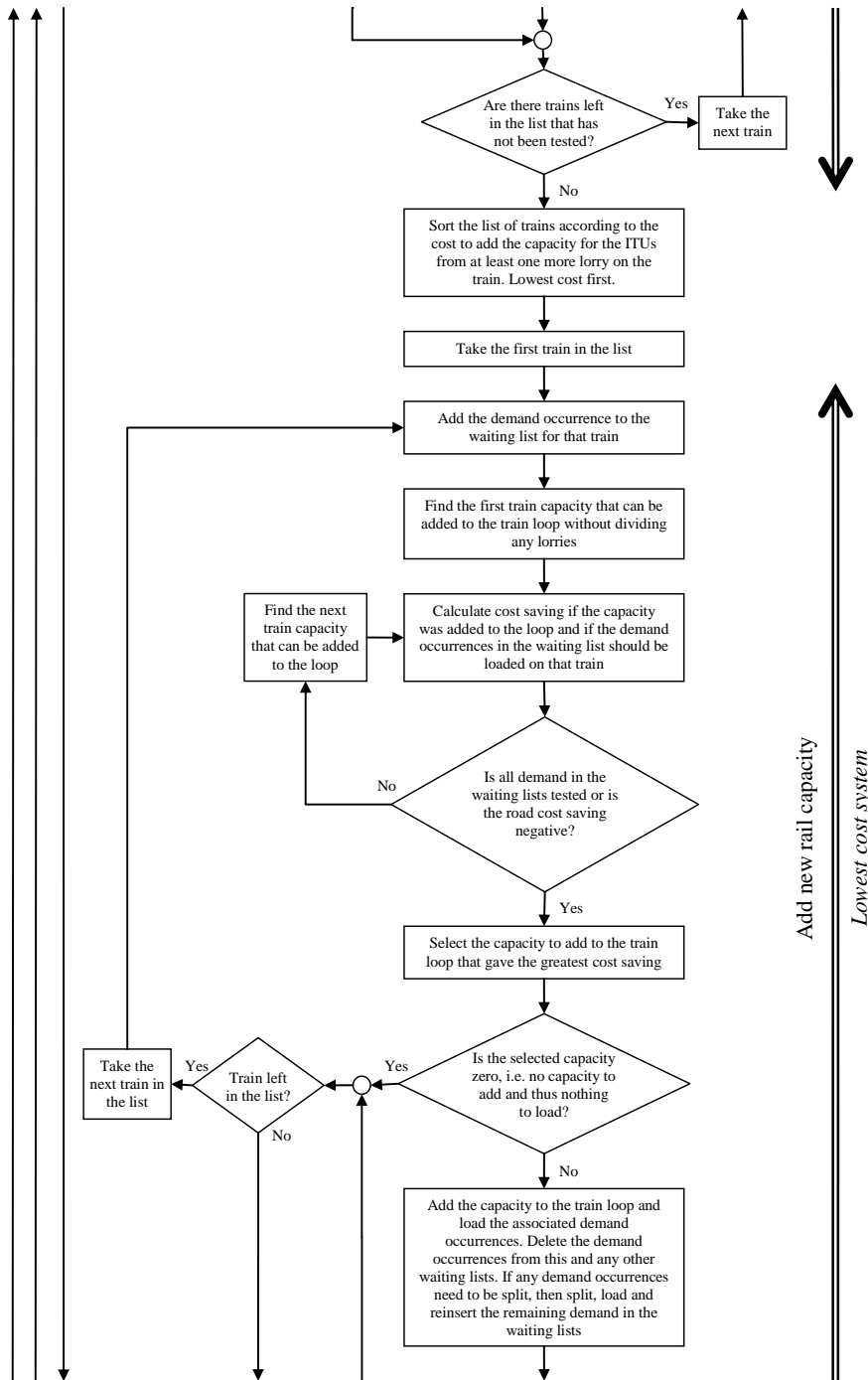

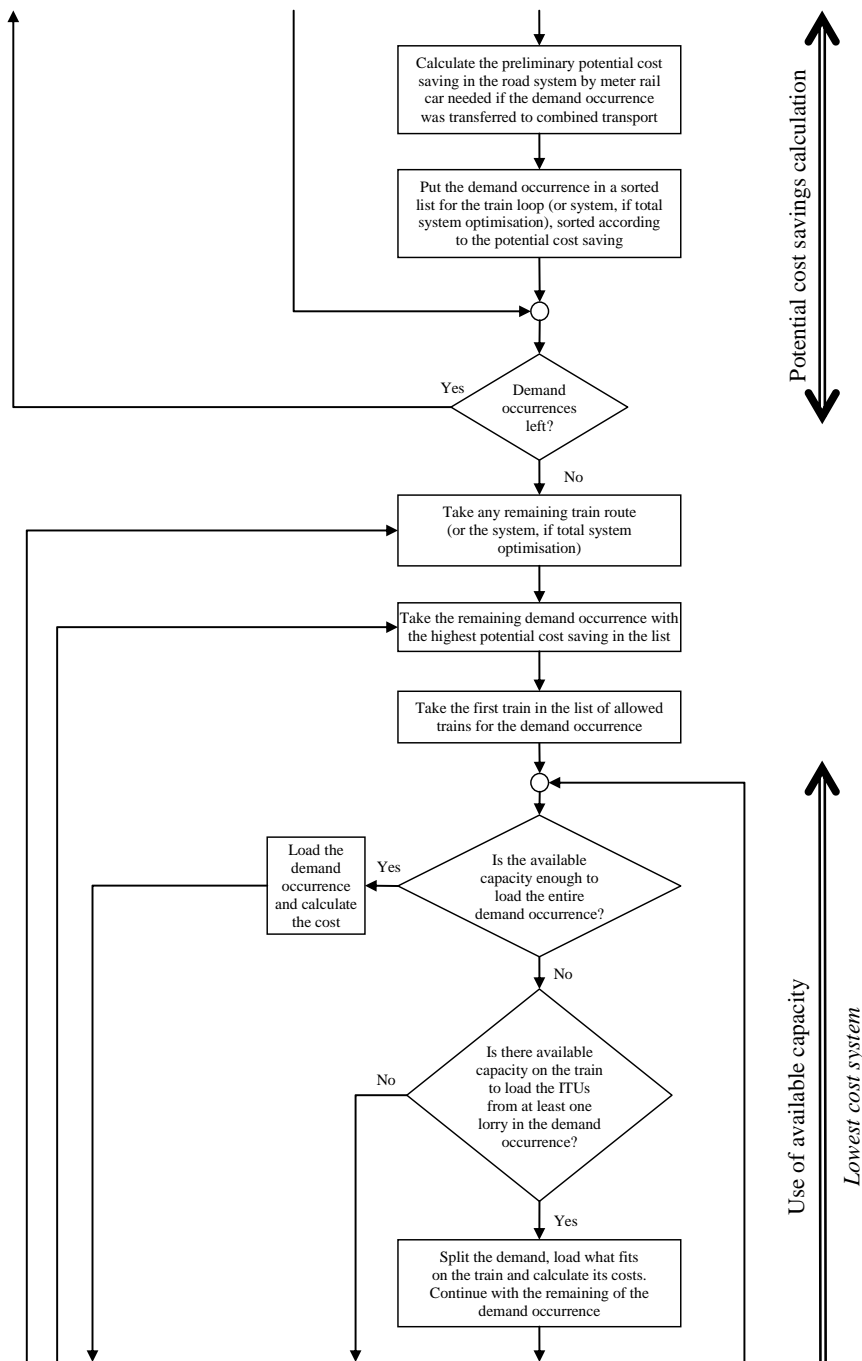

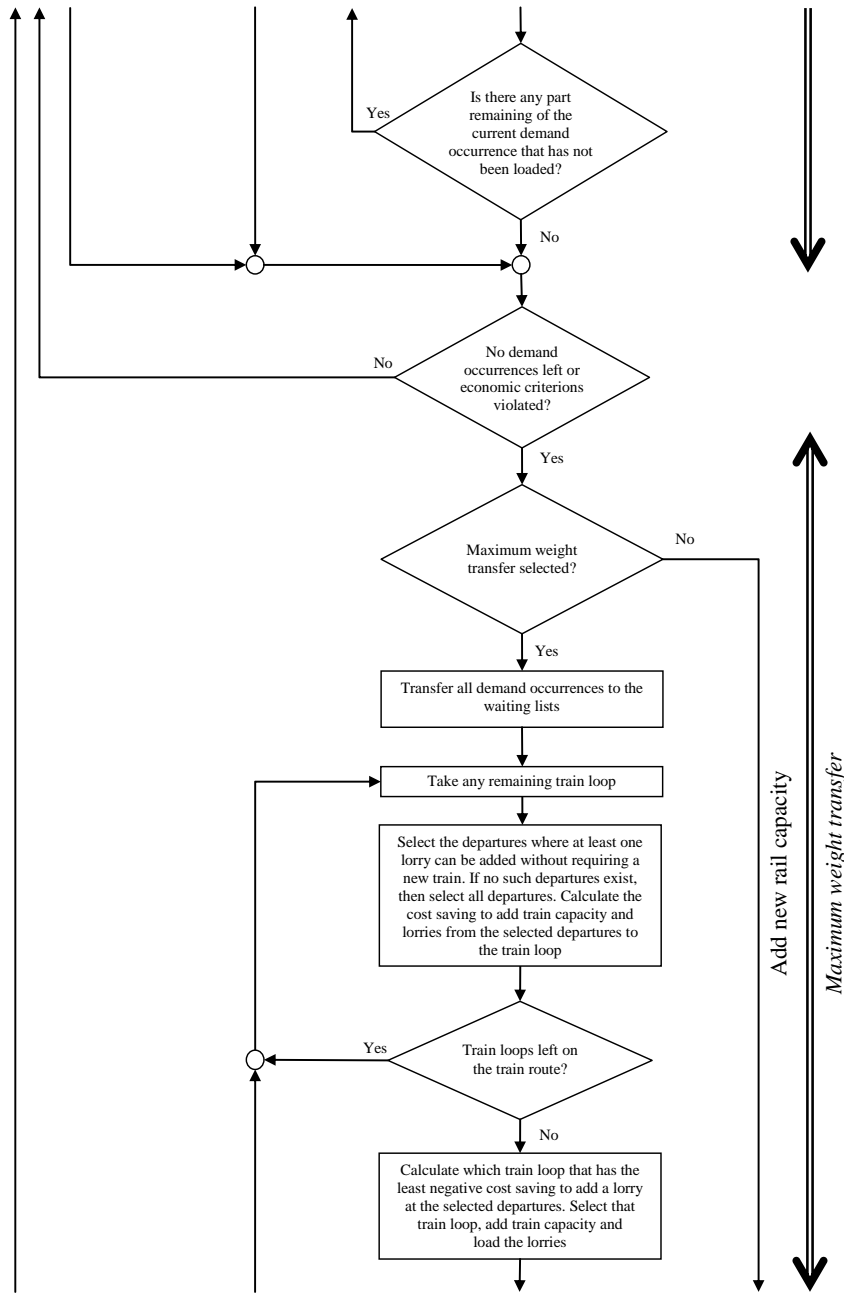

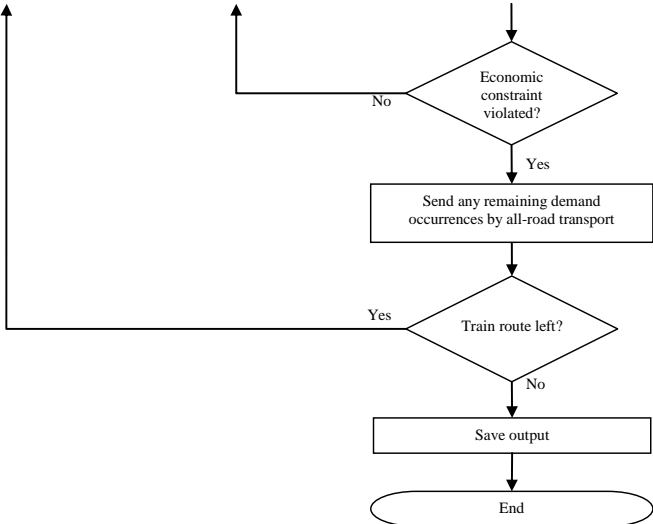

6 References

Flodén, J., 2007, *Modelling intermodal freight transport : the potential of combined transport in Sweden*, Doctoral thesis, Department of Business Administration, School of Business, Economics and Law at University of Gothenburg, BAS Publishing, Göteborg, <http://hdl.handle.net/2077/17141>

Jensen, A., 1990, *Combined transport: systems, economics and strategies*, Stockholm, Swedish Transport Research Board (Transportforskningsberedningen)

