

Publikationer från institutionen för pedagogik

1986:16

STUDENT FINANCIAL AID AND PARTICIPATION
IN HIGHER EDUCATION

Changes between 1965 and 1985 in Sweden

Sven-Eric Reuterberg

Allan Svensson



Institutionen för pedagogik
Göteborgs universitet

STUDENT FINANCIAL AID AND PARTICIPATION IN HIGHER EDUCATION

Changes between 1965 and 1985 in Sweden

Sven-Eric Reuterberg

Allan Svensson

Paper presented at the AERA Annual Meeting 1986

ABSTRACT

Reuterberg, S-E & Svensson, A. Student financial aid and participation in higher education. Publications from department of education and educational research, University of Göteborg. 1986:16

ISSN 0282-2180

Number of pages: 43

The aims of this study are to answer the following three questions:

- I What are the general recruitment effects of student aid?
- II What are the selective recruitment effects of student aid?
- III Have these effects changed over the last 15 years?

Three nationally representative samples of individuals born in 1953 and 1963 respectively are studied. Consequently, the study describes the recruitment situation in the late 1960's, in the early 1970's and in the early 1980's.

During this period the rate of transition from the upper-secondary school decreased from nearly 70% to less than 30. The role played by the financial aid in this connection has varied. From the late 60's to the early 70's, the proportion of students recruited by the aid decreased from 16% to 11. During the next 10 years the recruitment effect rose again so, at the end of the period studied, it reached the same level as in the late 60's.

In each cohort the transition rate of students from higher social groups exceeds that of students from lower groups by about 15 units of percentage. In spite of this unchanged influence of social background the effect of student aid has changed considerably. In the late 60's it had a substantial socially equalizing effect - an effect that vanished rapidly and, in the early 70's, student aid had no bearing on social differentiation. During the next 10 years the situation grew even more serious. In the early 80's, student aid namely was not only insignificant to social equalization but it even reinforced these differences by 3 units of percentage.

CONTENTS

Student financial aid in Sweden	1
The aims of the study	2
Samples and variables	2
Methods of analysis	7
The effects of the background variables on transition to higher education	12
Recruitment effects of student financial aid	21
Summary and discussion	30
References	39
Appendices	40

The research presented in this paper has been supported financially by the National Swedish Board of Universities and Colleges and by the Swedish Council for Planning and Coordination of Research.

Student financial aid in Sweden

In Sweden, since 1918, there has been a national system of student financial aid aimed at improving the equality of educational opportunity. From the beginning the aid was very limited in character and consisted entirely of interest-free loans. From the late 1930's to the 1950's there was an expansion of the system. A few new types of loans were added as well as a limited number of state scholarships. Despite this expansion only a minority of students had access to the student aid. Therefore, high demands were placed on achievement in studies and the student's need was also examined in relation to his/her own financial situation as well as to that of his/her parents.

In 1965 the student financial aid system was changed radically. Every student who comes up to the financial requirements has a right to receive the aid when entering a program of post-secondary education. At this point there is no test of academic ability, but after the first academic year the student has to demonstrate satisfactory academic progress in order to be eligible for continued aid. The examination of need in relation to the parents' income or private means ceased.

The aid consists of a grant and a repayable loan. When it was introduced the grant represented 25% of the total sum but this proportion has been gradually reduced and now, in 1985, it represents only 6%. This declining grant proportion is due to the fact that the total sum received is linked to the cost of living index and when this index is raised according to inflation, only the repayable part of the aid is increased. On some occasions the grant, too, has been raised but only by small amounts.

The loan part is interest-free but the debt sum is adjusted upwards by 4.2% per year. Earlier this percentage was 3.2.

It is not possible to give more detailed information about the aid system here. For those who are interested we would like to refer to Blaug and Woodhall (1978) and Woodhall (1982).

The aims of the study

When the present system was introduced in the mid-60's there was a strong belief that economic support would be an effective means to enhance equality of educational opportunity in transition to higher education. The aim of the study is to examine whether this belief has been realized or not concerning equality between socio-economic groups and equality between sexes.

The questions formulated are:

- I What are the general recruitment effects of student aid?
- II What are the selective recruitment effects of student aid?
- III Have these effects changed over the last 15 years?

By general recruitment effects is meant: the extent to which student aid has increased the overall transition rates.

By selective recruitment effects is meant: the extent to which the recruitment effects differ between socio-economic groups and between sexes.

The results will be presented in two sections. In the first one we will examine the actual importance of social background and sex on transition rate and those changes which have occurred in these respects during the period mentioned. In the second section we will answer the questions formulated above.

Samples and variables

Three nationally representative samples are studied. The two oldest samples were taken from the Individual Statistics Project and they include all Swedes born on the 5th, 15th and 25th of any month in 1948 and 1953 respectively. The older sample includes a total of some 12,000 individuals and the newer one a total of some 11,000 individuals. In each sample about 90% of all individuals were in the sixth grade within the compulsory school system on the first occasion when data were collected. The basic data collected at that time consist of:

1. Information from school records and information on social background.
2. Scores on intelligence tests, scores on standardized achievement tests and replies to questionnaires on the pupils' attitudes to school, their spare time interests and plans for study and work.

This basic information has been supplemented up to 1980 for those born in 1948 and up to 1982 for those born in 1953. Further information on the Individual Statistics Project may be found in Härnqvist and Svensson (1973).

The third sample includes some 10,000 individuals born in 1963. In this case the sampling technique is different. The individuals are stratified according to the program chosen in the upper secondary school and the proportions of individuals sampled differ from one program to another. This sampling technique implies that we have to weigh the results of each subgroup in such a way that the results will be representative of those of the population. This sample has been followed up by the Swedish National Central Bureau of Statistics. The first data collection was made in 1980 and in 1983 another data collection was carried out. In both cases the data were collected by questionnaires.

For all three samples information about post-secondary education is taken from central registers. This information includes, among other things, the year of registration and the course of study chosen.

The variables used in this study are socio-economic group, sex, achievement in compulsory school, enrollment in higher education and recruitment effects of student aid. Since we are interested in the transition from secondary to higher education we also have to identify those individuals who have entered the upper secondary school. Some of these variables require a more detailed definition:

Socio-economic group is identified by means of information on the fathers' education and occupation. Two groups are distinguished: group I, which includes each individual, whose father has a formal education beyond compulsory school, and group II, which includes the other individuals.

Achievement refers to marks in the compulsory school. For the two oldest cohorts the marks are taken from the sixth grade and for those born in 1963 the marks are taken from the ninth grade.

The groups are divided into two achievement levels, those above the median (high achievement) and those below (low achievement). Since we are studying only those individuals who have entered the upper secondary school the median refers to this group. Therefore, low achievement does not mean that the individuals are low achievers with reference to all individuals in the age group but only with reference to those who have entered this educational level. As a matter of fact, low achievers in this study constitute a positive selection from all individuals in the cohort.

Higher education does not mean all those courses of study which are included in higher education today. In 1977 higher education in Sweden was reformed. Among other things, this reform implied that some post-secondary courses were now classified as higher education, e.g. courses in nursing and in pre-school and leisure education. These courses were not included in the central registers before 1977. Therefore, it is not possible for us to study the transition into them.

Consequently, in this study the concept of higher education is used in a traditional way and it includes faculties of arts and sciences, technical colleges and faculties of law, theology, medicine and odontology. Furthermore, schools of education are included.

For the youngest cohort we have information on the individuals' educational choices up to the end of 1984, i.e. until the age of 21. In order to make the results comparable between the cohorts the same age-limit is applied to all of them. This means that we are studying the recruitment effects of student aid among young students during the following periods: late 60's (up to 1969), early 70's (up to 1974) and early 80's (up to 1984). The design of the study is summarized in figure 1.

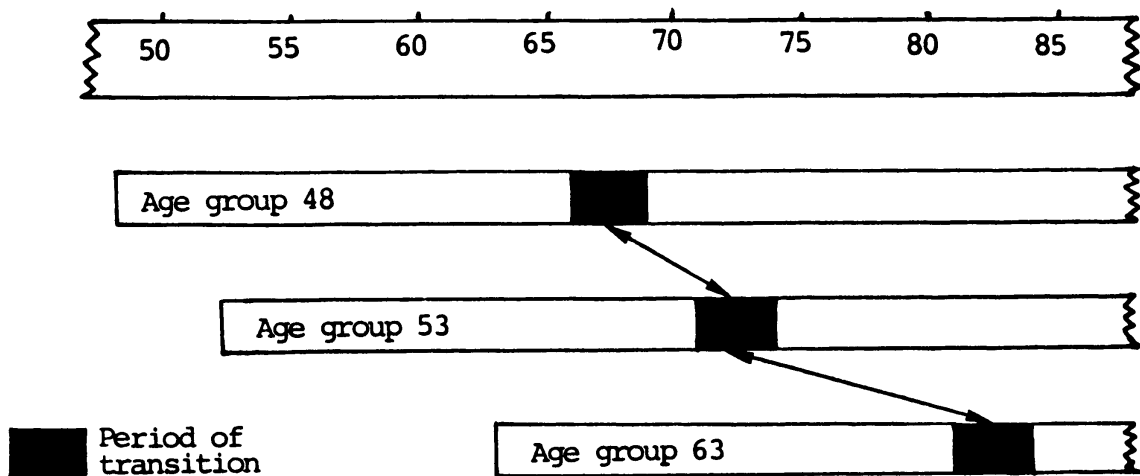

Figure 1. *The design of the study.*

The two oldest cohorts have previously been the subjects of investigations as to the effects of student aid. Reuterberg & Svensson (1983) have examined to what extent the aid has been used by the students in the oldest cohort and the importance of the aid for their chances of completing studies successfully. Furthermore, Reuterberg (1983) has made a comparison between the 1948 and 1953 cohorts as to the importance of student aid to degree completion in higher education.

Recruitment effects of the student aid has been measured via the questionnaires. The question given to the two oldest cohorts reads:

If there had been no student aid available when you entered higher education would you have begun to study at all?

- Yes, definitely()
- Yes, probably()
- | No, probably not()
- | No, definitely not()

Those individuals who have answered the two "no"-alternatives has been regarded as recruited by the student financial aid.

Since the questionnaires were given to the two oldest cohorts when the individuals were at the age of about 30 they have judged the importance of the aid retrospectively. To the youngest cohort the question was given in 1983 which means that they had to judge the importance of the aid at the time when they were deciding on their educational choice. The question put to them reads:

What is the importance of student aid for your decision on entering higher education?

- | Very great importance()
- | Great importance()
- Small importance()
- No importance at all()

Those having chosen the two first mentioned alternatives have been regarded as recruited by the student aid.

Now, it is legitimate to question whether the information received from the youngest cohort differs from that given by the two oldest cohorts to such an extent that comparisons are invalidated. In our opinion this is not so. We will make comparisons between socio-economic groups and between sexes within each cohort and we do not think that these comparisons are influenced by the wording of the questions to such an extent that the results are invalidated.

Finally, by *secondary education* is meant that the individuals are in the upper secondary school at the age of 17. Just as the concept of higher education has been broadened so has the concept of

upper secondary school. Since 1971 the upper secondary school includes several two-year programs but in order to get a definition as uniform as possible, those individuals who have entered two-year programs are excluded in this study.

The group sizes are presented in appendix I.

Methods of analysis

Within each age group the variables have been ordered in the following causal model:

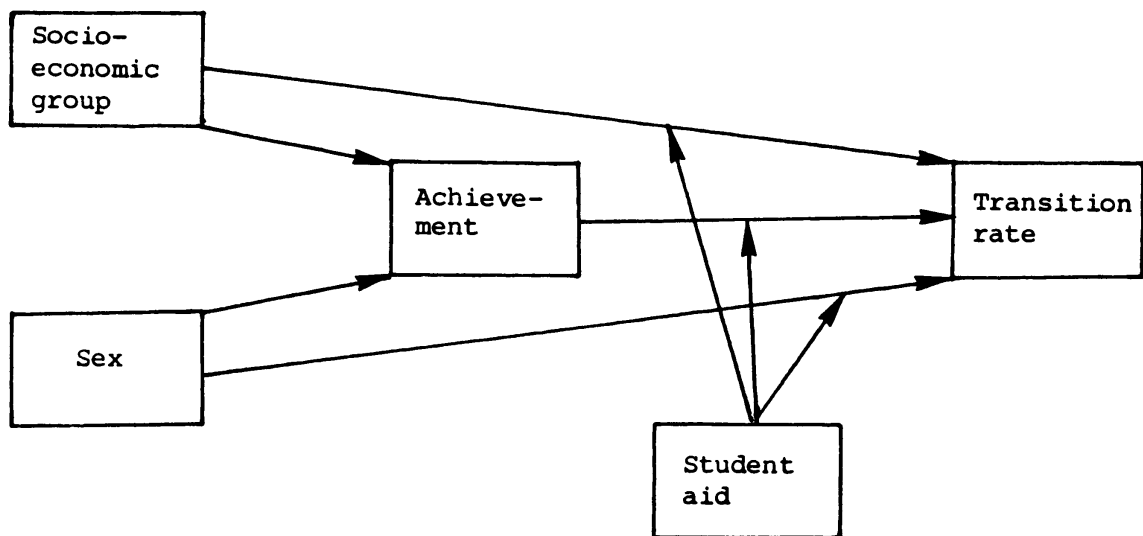

Figure 2. *Causal model of the variables involved in the analyses, which are made within each age group.*

The arrows in figure 2 describe direct effects. This means the effect of one variable on another one, all the other variables in the model being kept under control. As shown in the figure there is no arrow between socio-economic group and sex. This is due to the fact that there is no causal relationship between them. Nevertheless, they are not completely uncorrelated within each

cohort owing to the fact that we are not studying the total cohorts, but only those individuals who have entered the upper secondary school. In order to eliminate this interrelationship we will control for sex when studying the effects of socio-economic group on achievement and transition rate and vice versa when studying the effects of sex. Besides the direct effects, socio-economic group and sex influence transition rate indirectly via achievement. These indirect effects are calculated by multiplying the direct effect on achievement and the direct effect of this variable on transition rate.

By adding the direct and the indirect effect we get the total effect of socio-economic group and sex respectively on transition rate.

The effects are expressed as differences between proportions. When calculating the effect of sex on achievement we calculate the proportion of high achievers among men and women respectively. The difference between these proportions constitutes the measure of the effect. In order to keep social background constant these calculations are made within each socio-economic group. After that these two effects are weighed according to group sizes and summed up.

A more detailed account of this technique is given by Hellevik (1983). Furthermore, we will give an example of it in appendix II.

In figure 2 there are also arrows directed from student aid towards those arrows showing the direct effects on transition rate. These vertical arrows symbolize the influences of student aid on the direct effects on transition rate. The influences of student aid are calculated in the way we have described above, but now we replace the transition rates by the proportions of students who have been recruited by the aid.

The effects described so far are valid for the total cohort, but they do not show whether the effects differ or not between different subgroups within the cohort. For instance, they do not show whether the effects differ between students of high and low achievement respectively. In order to test these interactions we will use a statistical method called log-linear models (LLM). It is not possible to give a detailed account of LLM in this report but introductory accounts of it are given by Everitt (1977) and Baker (1981) and a more detailed one is given by Bishop, Fienberg and Holland (1975).

LLM has the advantages of testing the strength of the interaction at the same time as it constitutes a measure of the effects of the independent variable on the dependent one.

The statistical testing is done by the technique of model adaptation. For instance, if we have a group simultaneously classified according to three variables A, B and C (which is the case when we are studying the transition rate in relation to social background and achievement) the actual frequencies (F) of the multidimensional table can be reconstructed exactly by the following expression:

$$F = GM + A + B + C + AB + AC + BC + ABC,$$

where GM is a measure of the total group size,

A, B and C are measures of the main effect of each variable,

AB, AC and BC are measures of the interrelationships between the variables and

ABC is a measure of the interaction between the three variables.

By transforming the frequencies into natural logarithms the original multiplicative model is made additive. This means that the components of the expression above are expressed as natural logarithms.

As said before, when all components are included in the model the actual frequencies are reconstructed exactly. If we exclude the interaction ABC the frequencies predicted by the remaining components may deviate from the actual ones. How great this

deviation will be depends on the strength of the interaction ABC. The stronger the interaction the greater the deviation. The magnitude of this deviation is expressed as a G^2 -value, which has a distribution similar to Chi^2 .

When many variables are included in the analysis the interpretation of the interactions may be somewhat troublesome. However, LLM gives estimates of the parameters on which the interpretation can be based. Since these estimates are very abstract measures we have chosen a different technique. We simply predict the frequencies with the interaction under interpretation being excluded. After that, these predicted frequencies are compared to the actual ones. This technique, which previously has been used by Reuterberg (1984), is illustrated in appendix III.

Comparing differences between proportions is normally a troublesome operation (Anderson, 1975; Noonan & Elggvist-Saltzman, 1982; Reuterberg, 1985). This is due to the fact that there is no linear relationship between a dependent variable and an independent one, the latter being expressed as proportions. Instead this relationship is described by an S-shaped curve as shown in figure 3.

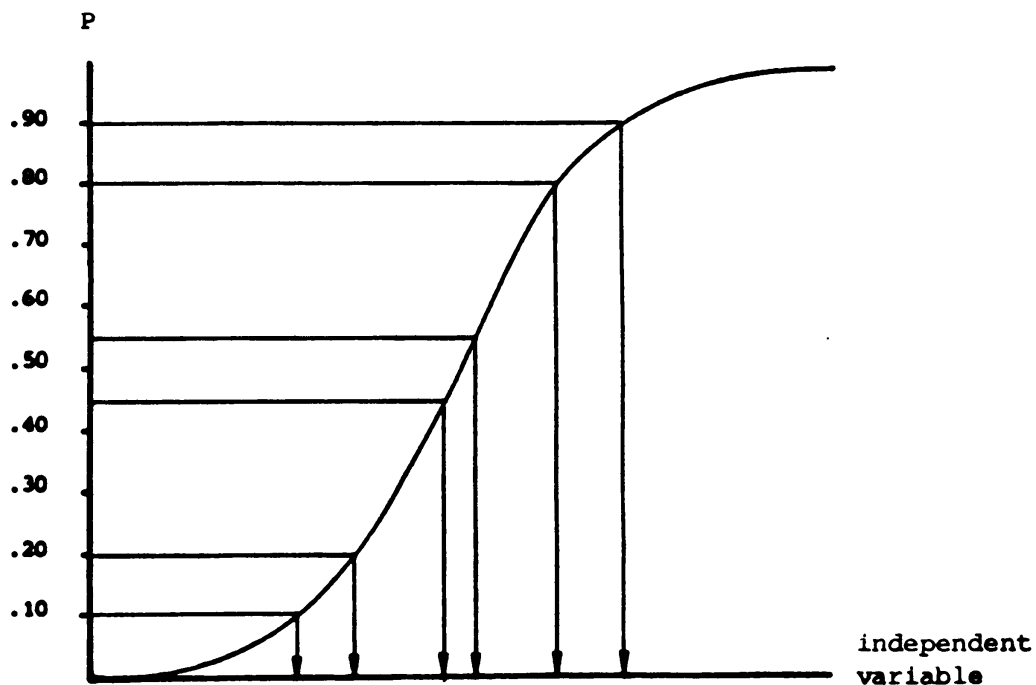

Figure 3. *The relationship between an independent variable and a dependent variable when the latter one is expressed as proportions (P).*

The curve implies that it is harder to change a very low or a very high proportion than it is to change a proportion around 0.50. Consequently, a difference between proportions of 0.10 expresses a greater effect of the independent variable if it occurs in the extreme parts of the curve compared to its occurrence in the central parts as the figure shows.

By transforming the frequencies into natural logarithms the S-shaped curve is made linear. Therefore, LLM gives a measure of *the effects* of the independent variable and not a measure of *the magnitude of the differences* between proportions. Consequently, two differences of exactly the same magnitude can stand for differing effects.

In this report LLM is used not only in the analyses within each cohort but also when studying differences between the cohorts.

The method of sampling used within the youngest cohort causes some problems in connection with the statistical testing. It makes the probabilities of sampling error invalid. In order not to make the analyses too complicated we have transformed the frequencies of the sample into population frequencies. In doing so we receive representative results for the whole population as well as for the subgroups used in this study. When analyzing the results with the aid of LLM these "population frequencies" have been divided by a constant chosen so that the total number of individuals will correspond to those of the two older samples. This technique implies that the G^2 -values received will be comparable between all the three samples as measures of the strength of the interactions. Even if the probabilities of sampling error are not relevant as to the youngest cohort, G^2 -values corresponding to 5% significance level will be regarded as indicating an interaction worth-wile further examination. Those interactions which are weaker will be ignored.

The effects of the background variables on transition to higher education

The results will be presented in two separate steps: first we will show the influences of the background variables on transition rate, after that we will show in what way these influences are changed by student financial aid.

In order to examine the influences of the background variables we have to know the overall transition rates of the age groups and also the internal relationship between the background variables within each cohort.

Table 1. *Overall transition rate by age group. Proportions.*

Students born in	1948	1953	1963
	.68 ¹⁾	.39	.29

1) .68 means the proportion 0.68 or 68 per cent.

The overall transition rate decreases gradually and in the youngest age group it is less than half as high as the rate of the oldest one. Even if the decrease goes on during the whole period studied, it is most salient between the 1948 and 1953 cohorts, which means that transition rate into higher education dropped most rapidly in the beginning of the 70's.

This trend of receding recruitment of young students to higher education is a well-known fact in Sweden and the admission rules have been changed in order to increase the proportion of young people among the freshmen.

The changing transition rates imply that differences in rates between subgroups will not be comparable from one age group to another as measures of the *effects* of the background variables. According to our earlier discussion (p 11) a constant difference

implies a greater effect the more extreme the overall transition rate. Consequently, we will have to make corrections of the differences between subgroups in the manner that we have described before.

In table 2, below, we show the relationships between background variables and transition rates, the relationship being expressed as differences between proportions. A positive difference means that the transition rate is highest among

- students from socio-economic group I
- men
- students of high achievement

Table 2. *The relationships between background variables and transition rates. Differences between proportions.*

Background variable	Born in		
	1948	1953	1963
Socio-economic group (SES)	.15	.17	.16
Sex	.01	.04	-.04
Achievement (ACH)	.12	.20	.31

As said before, these values are not comparable between the cohorts due to the varying overall transition rates. Therefore, the values shown in table 3 have been based on the corrected values, which are the measures of the effects. However, in order to show the changes of these effects, the effects of the oldest cohort are given the value 0.00. Those of the other two cohorts are expressed as deviates from the values of the oldest one.

Table 2 shows that the transition rate of socio-economic group I exceeds that of group II by about 15 units of percentage within each cohort and as can be seen in table 3 (next page), these differences represent an unchanged effect. Therefore, the conclusion is that the decreasing overall transition rate has not led to any change in the effect of social background on transition rate.

Table 3. *Changes of the effects of background variables on transition rates.*

Background variable	Born in		
	1948	1953	1963
SES	.00	.00	.00
SEX	.00	+.02	-.05
ACH	.00	+.05	+.20

On the contrary, the effects of sex and achievement have changed during the period studied. Within the two oldest cohorts men have entered higher education somewhat more often than women but during the late 70's and early 80's the women have passed the men so that their transition rate is somewhat higher. However, it should be said that sex is of less importance to enrollment in higher education than social background.

When considering the effects of achievement it must be remembered that the individuals involved in this study are those who have entered the upper secondary school, which means that achievement has been subjected to restriction of range. This is the main explanation for the fact that achievement shows a lower relationship with transition rate than does socio-economic status within the oldest age group. However, the significance of achievement grows gradually over time and within the youngest cohort it has become the most important factor for transition rate. In table 3 we can see that the most remarkable increase occurs between the two youngest cohorts. One reason for this is the introduction of a general restricted intake to higher education. Earlier there was an open admission to quite a lot of courses especially within the faculties of arts and sciences.

Since the admission rules have been changed it is reasonable to ask whether this is the only cause of the transition rate decrease shown in table 1 and the increased significance of achievement shown in

table 3. The answer to both these questions is no. As can be seen in the tables, the changes mentioned, occur to some extent already between the two oldest cohorts, i.e. before the introduction of the new admission rules. Furthermore, the transition rate has decreased also among students of high achievement. One important reason for this is that the labour market for people who have a university education has deteriorated considerably. Therefore, many young people have refrained from higher education.

Simultaneously student financial aid has become less favourable as we have discussed earlier and the main aim of this study is to make clear the contribution of the aid to the changed recruitment pattern. However, in order to do so we first have to examine in greater detail the influences of the background factors on transition rate.

We start this analysis by studying the interrelationships between background variables.

Table 4. *Interrelationships between background variables.
Differences between proportions.*

Background variables	Born in		
	1948	1953	1963
SES - SEX	.01	.01	-.07
SES - ACH	.01	.01	.06
SEX - ACH	-.10	-.07	-.22

The most substantial interrelationships are found between sex and achievement. Throughout they are negative which means that women show a better achievement than men. This is a well-known fact and need no further comments. On the other hand, it might be more surprising to find practically no relationship between socio-economic group and ability within the two oldest cohorts and only a moderate one among those born in 1963. The reason for this is

that only students in the upper secondary school are included in the study and to that educational level there is a selection according to achievement which is especially strong within the lower socio-economic groups.

As shown by table 4 there is a clear difference between the age-groups, the relationships being highest within the youngest cohort. This is due to the fact that this group shows a somewhat different pattern of recruitment to the upper secondary school. The most pronounced difference is that women from lower socio-economic groups have increased their participation on this educational level.

The fact that the interrelationships vary in this way gives cause for a further examination of the influences of the background variables on transition rate to higher education. This further examination implies that the total effect of the background variables is divided between direct and indirect effects in the way that we have described before (p 8).

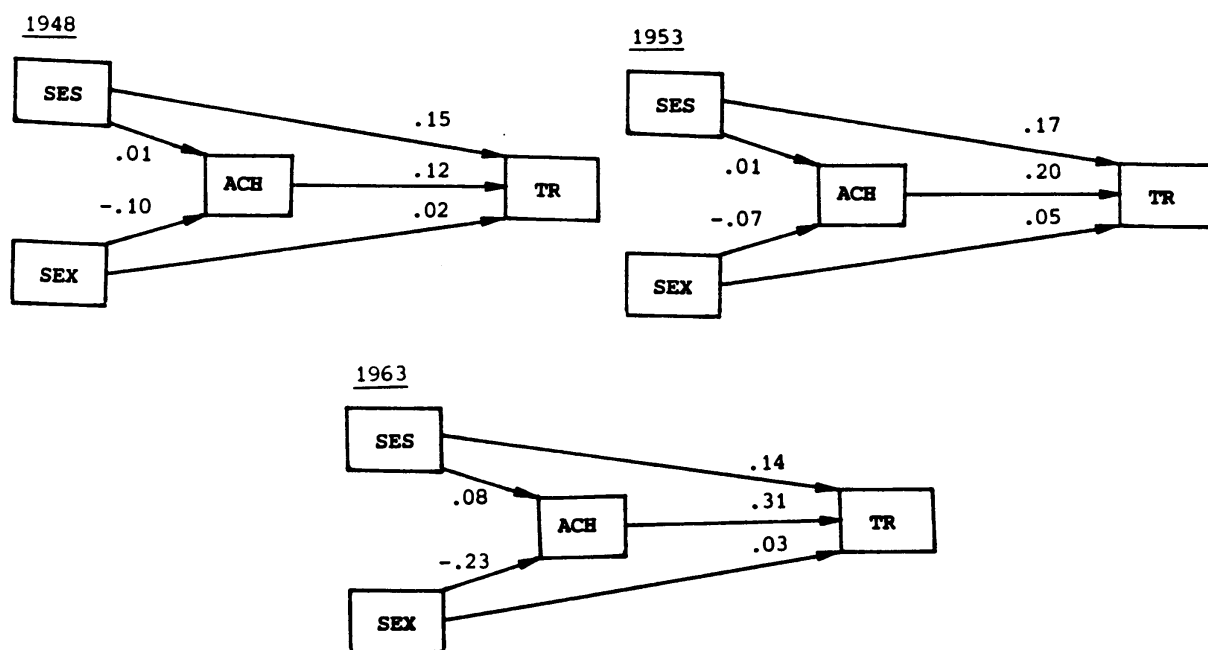

Figure 4. *Direct effects of the background variables on each other and on transition rate (TR) to higher education.*

Table 5. *The total effects of the background variables on transition rate divided between direct and indirect effects.*

<u>EFFECT:</u>	<u>Born in 1948</u>			<u>Born in 1953</u>			<u>Born in 1963</u>		
	Direct	Indirect	Total	Direct	Indirect	Total	Direct	Indirect	Total
SES	.15	.00	.15	.17	.00	.17	.13	.03	.16
SEX	.02	-.01	.01	.05	-.01	.04	.03	-.07	-.04
ACH	.12	-	.12	.20	-	.20	.31	-	.31

Figure 4 shows those direct effects which the background variables exert on each other and on transition rate. On the basis of these effects we can compute the indirect effects which social background and sex exert via achievement. The direct as well as the indirect effects are shown in table 5.

Within the two oldest cohorts social background influences transition rate only as a direct effect. This is due to the fact that there is practically no relationship between social background and achievement. The relationship between sex and achievement is somewhat higher and to the advantage of women. Therefore, in this case there is a negative indirect effect, however weak. This means that women's higher achievement tends to counteract the sex differences in transition rate to the advantage of men by 1 unit of percentage.

Achievement, which is the last background variable in the model, exerts only a direct effect and within the two oldest cohorts this effect is of about the same strength as that of social background.

Among those born in 1963 achievement shows a closer relationship with both social background and sex. Therefore the indirect effects are greater within this cohort. As to social background we can see in table 5 that the direct effect is somewhat weaker in this cohort than in the other two but owing to the indirect effect the total effect is of about the same strength as those found among students born in 1948 and 1953 respectively.

Within the youngest cohort there is a sex difference in transition rate to the advantage of women. As shown by table 5 this is entirely caused by achievement. If this variable is kept under control there is a sex-difference of 3 units of percentage to the advantage of men as shown by the direct effect. Consequently, we can state that the over-representation of women among young students in higher education is an effect of the sex differences in achievement in combination with the increased importance of achievement on enrollment into higher education.

Those effects discussed up to now are valid for the cohorts respectively taken as a whole. By examining interactions between the background variables and transition rate it is possible to study whether these effects are valid also for different subgroups within the cohorts.

Table 6. *Interactions between background variables and transition rate to higher education. G^2 -values.*

Interaction	Students born in		
	1948	1953	1963
SES * SEX * TR	2.18	0.22	0.72
SES * ACH * TR	1.16	0.47	5.89*
SEX * ACH * TR	4.25*	2.16	4.52*
SES * SEX * ACH * TR	0.38	0.96	2.89

According to our criteria (p 11) three interactions will be the subject of further examination. These are SEX * ACH * TR among those born in 1948 and 1963 respectively and SES * ACH * TR among those born in 1963. Within the 1953 cohort there is no interaction to be examined and therefore we can state that the conclusions drawn on the basis of figure 4 and table 5 are valid also for the subgroups of this cohort.

In table 7 we show the interaction SEX * ACH * TR for students born in 1948 and 1963 respectively.

Table 7. *The influences of sex and achievement on transition rate.*

Students born in 1948				Students born in 1963			
SEX	ACH	TR	Difference	SEX	ACH	TR	Difference
Men	High	.73	-.02	Men	High	.49	.07
	Low	.65			Low	.13	
Women	High	.75	.07	Women	High	.42	-.01
	Low	.58			Low	.14	

In table 7 we can see that among those born in 1948 there is a clear difference in transition rate to the advantage of men among students on a low achievement level. On a high achievement level, on the contrary, the women have a slightly higher transition rate. However, among those born in 1963 the sex differences are of a different nature. Now, the sex difference in favour of men is found among students of high achievement, while women's transition rate exceeds that of men by one unit of percentage among students of low achievement.

Since one difference is positive and the other one negative, the effects differ in nature. Therefore, in these cases we need no special measures of the effects.

The interaction among those born in 1963 may be regarded as confusing in the light of the fact that in table 3 we showed that women's transition rate was higher than that of men. However, the explanation of these seemingly contradictory results is that the interaction includes all the three variables sex, achievement and transition rate. Therefore, the differences in table 7 together constitute the direct effects of sex on transition rate. As shown in table 5 this direct effect is positive, i.e. to the advantage of men.

To sum up we can say that keeping achievement under control implies that the transition rate of men is higher than that of women. But according to the interactions in table 6 and the interpretations of them (table 7) this sex difference emanates from different parts of the achievement continuum. Among students born in 1948 the difference is confined to students of low achievement. Among students born in 1953, for whom no interaction was found, the total difference is valid irrespective of achievement level, but for the youngest cohort it is confined to students of high achievement. Consequently, the origin of the overall sex difference in transition rate, achievement being under control, has moved upwards the achievement level.

Finally, one interaction remains to be examined, namely SES * ACH * TR among students born in 1963.

Table 8. *The influences of social background and achievement on transition rate. Students born in 1963.*

SES	ACH	TR	Difference	Effect
I	High	.53	.14	-.04
	Low	.22		
II	High	.39	.13	+.04
	Low	.09		

In this case, the differences are positive irrespective of achievement level. Furthermore, they are of about the same magnitude, but still there is a substantial interaction. As we discussed before this is due to the fact that students of low achievement on the whole show the lowest transition rate. Therefore, the difference of 0.13 expresses the biggest effect of social background on transition rate as shown by the last column of table 8.

Consequently, we can conclude that among students born in 1963 social background exerts its biggest effect on transition rate among students of low achievement. The other two cohorts did not show any substantial

interaction between these variables so in these cases we conclude that social background is of about the same importance to transition rate irrespective of achievement level.

The interactions discussed in tables 7 and 8 are also the reasons why there are substantial interactions in table 9 between age group, socioeconomic group, achievement and transition rate, as well as between age group, sex, achievement and transition rate. Therefore these interactions need no further comments. As can be seen in table 9 the other interactions including age group are reasonably small.

Table 9. *Interactions between age group, background variables and transition rate to higher education. G^2 -values.*

<u>Interaction</u>	
AGE * SES * SEX * TR	2.35
AGE * SES * ACH * TR	7.40*
AGE * SEX * ACH * TR	9.51*
AGE * SES * SEX * ACH * TR	4.19

Note: In table 9 degrees of freedom are 2. Critical value: $G^2=5.99$

Recruitment effects of student financial aid

In table 10 we show the proportions of students at secondary educational level, who have been able to enter higher education thanks to student financial aid.

Table 10. *The proportion of students, recruited to higher education by student financial aid.*

<u>Students born in</u>	<u>1948</u>	<u>1953</u>	<u>1963</u>
	.16	.11	.17

The proportions in table 10 should be seen in the light of the decreasing rates of transition to higher education. As we showed in table 1 this decrease continued during the whole period studied and, in total, it amounted to nearly 40 units of percentage.

In table 10 we can see that the proportions of students recruited by student aid vary between 11 and 17 per cent. The highest proportions are found among students born in 1948 and 1963 respectively and the lowest one within the intermediate group. Consequently, the receding recruitment effect of student aid between the two oldest cohorts is simultaneous with a decreasing overall rate of transition to higher education. However, the overall transition rate decreased much more dramatically - by 29 units of percentage. Therefore, we can conclude that student aid is a factor contributing to the receding recruitment of young students to higher education during the early 70's. However, it is not the only one - probably not even the most important one. What the other factors may be will be discussed in the final section of this report.

As said before recruitment to higher education continued to decrease during the late 70's and early 80's, but this decrease cannot be explained by a weakening recruitment through student aid. Instead, this recruitment has increased by 6 units of percentage, so during this period, student aid has counteracted the receding recruitment of young students to higher education.

Now the question is whether student financial aid has counteracted the effects of the background variables on transition rate. In order to answer that question, we turn to the causal models and to the tables showing in what way student aid has changed the direct and the indirect effects of the background variables on transition rate. By adding the influences on these two kinds of effects we also find out the influences of the aid on the relationship between the background variables and transition rate.

In figure 5 we show the direct effects of the background variables on each other as well as their direct effects on transition rates. This is the same information that was given in figure 4. However,

figure 5 also includes the influences of student aid on the direct effects of the background variables on transition rates. On the basis of these influences of student aid we can compute in what way the indirect effects of background variables on transition rate are changed by the aid.

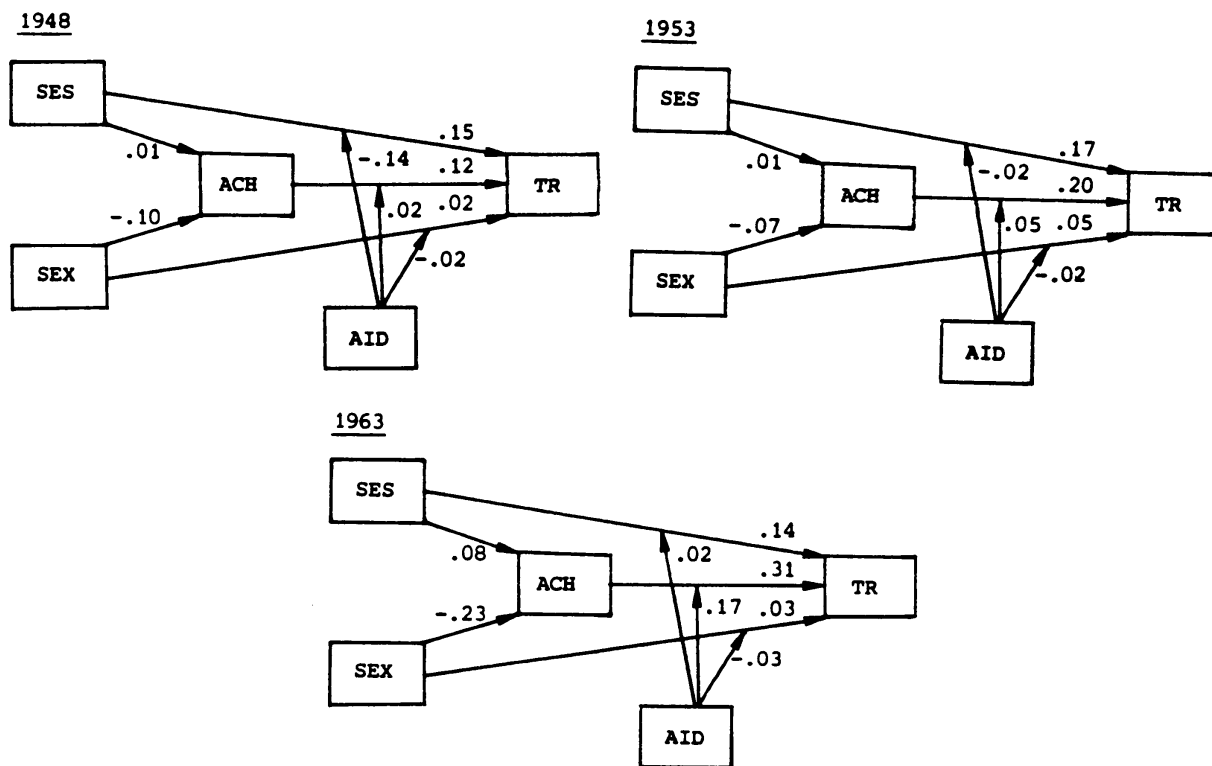

Figure 5. *The influences of student financial aid on the direct effects of the background variables on rates of transition to higher education.*

Table 11. *The influences of student aid on the direct and the indirect effects of background variables on rates of transition to higher education.*

EFFECT:	1948			1953			1963		
	Direct	Indirect	Total	Direct	Indirect	Total	Direct	Indirect	Total
SES	-.14	.00	-.14	-.02	.00	-.02	.02	.01	.03
SEX	-.02	.00	-.02	-.02	.00	-.02	-.03	-.04	-.07
ACH	.02	-	.02	.05	-	.05	.17	-	.17

Among students born in 1948 student aid has had a substantial socially equalizing effect. As shown by figure 5, it has reduced the direct effect of social background on transition rate by 14 units of percentage, which means that in the absence of the aid this effect would have been twice as large. However, this positive influence seems to be temporary. Among those born 5 years later student aid has reduced the direct effect of socio-economic group by only 2 units of percentage and within the youngest cohort the aid has even increased the importance of social background. This means that in the early 80's student aid has worked in a completely unintended way.

From table 11 we can see that the influence of student aid has mainly affected the direct effects. Only within the youngest cohort has there been a change - however small - in the indirect effect. This is due to the fact that this cohort shows a stronger relationship between socio-economic group and achievement at the same time as student aid has strongly increased the effect of achievement on transition rate.

The conclusion based on these results must be that shortly after its introduction student aid was a significant tool for counter-acting the impact of social background on transition from secondary to higher education. Soon, its effect in this respect ceased and in the early 80's student aid has become a factor which increases the importance of social background.

As to the sex differences in transition rate student aid has had relatively small influences within the two oldest cohorts. For both of them the sex difference has been reduced by 2 units of percentage. This means that the aid has been of a somewhat greater significance for women than for men.

This applies to the youngest cohort too. But now the situation is different. As shown in table 2, among students born in 1963, women have entered higher education more often than men. On the basis of the information given in figure 5 and table 11 we can conclude that this changed sex difference is entirely an effect of student financial aid. As a matter of fact, it has been to the advantage of women in two different ways. Firstly, student aid has reduced the positive direct effect of sex on transition rate. Secondly, it has increased the negative indirect effect. In total, the recruitment effect of student aid among women exceeds that among men by 7 units of percentage. This should be compared to the actual sex difference in transition rate, which according to table 5 amounts to 4 units of percentage. Consequently, we can infer that if there had been no student financial aid the sex difference in the rate of transition to higher education would have been to the advantage of men within the youngest cohort too.

During the whole period studied, the financial aid has increased the importance of achievement for enrollment into higher education. This means that the aid has recruited mainly students of high achievement. Furthermore, this tendency grows stronger as time goes by, so within the youngest cohort it has become substantial.

From one point of view this can be seen as a positive result since it means that the aid helps to raise the ability level of the students in higher education. From another point of view the result can be seen as negative since it implies that social differences and sex differences in transition rate are increased within the youngest cohort. As can be seen in table 11 the indirect effect of socio-economic group on transition rate is increased by 1 unit of percentage. Certainly, this effect is not yet large but if student aid continues increasing the importance of achievement for transition rate the situation may be more serious in the future.

The indirect effect of sex on transition rate via achievement is $-.04$, as mentioned before and this value corresponds to the total sex difference in transition rate. Consequently, we can conclude that, if the importance of achievement for transition rate had not been increased by student financial aid there would have been no sex differences at all in the rate of transition to higher education.

After having discussed the influences of student aid on the effects of background variables there remains to be examined whether these influences differ or not between different subgroups. This is done by examining the interactions between the background variables and the recruitment effects of student aid.

Table 12. *Interactions between background variables and the recruitment effects of student aid within age groups. G^2 -values.*

Interactions	Students born in		
	1948	1953	1963
SES * SEX * AID	1.89	0.15	0.59
SES * ACH * AID	0.04	0.57	25.17*
SEX * ACH * AID	1.98	2.61	0.08
SES * SEX * ACH * AID	0.43	0.31	0.04

Since all interactions including sex are weak, we can state that the influences of student aid on sex differences discussed above are valid also for different subgroups. However, this is not the case for socio-economic group. As can be seen in table 12, there is one substantial interaction between this variable, achievement and student aid. The meaning of this interaction is shown in table 13.

Table 13. *Recruitment effects of student aid by social background and achievement level. Students born in 1963.*

SES	ACH	AID	Difference
I	High	.23	-.05
	Low	.14	
II	High	.28	.08
	Low	.06	

The interaction examined in table 13 corresponds to the interaction SES * ACH * TR, which we have examined before in table 8. That table showed that irrespective of achievement level students from socio-economic group I entered higher education more often than students from group II. In spite of that there was a clear interaction and this was due to the fact that the effect of social background on transition rate was strongest among students of low achievement. Now, table 13 shows that student aid is a vital part in the interaction SES * ACH * TR. Student aid has reduced the social differences in transition rate among students of high achievement, so the effect of social background has been decreased in this case. Among students of low achievement there is an opposite tendency. The student aid has recruited mainly students from socio-economic group I and consequently, in this case student aid has increased the effect of social background.

Furthermore, table 13 shows that the positive difference among students of low achievement is numerically greater than the negative difference among students of high achievement. That is why student aid has had an overall socially differential effect on the rate of transition to higher education. In other words, this overall differential effect of student aid is exclusively a phenomenon among students of a low achievement level. This is an interesting result which will be discussed in the final section of this report.

Now, the interactions with age group, background variables and the recruitment effect of student aid involved remain to be presented. This is done in the following table.

Table 14. *Interactions between age group, background variables and the recruitment effects of student aid. G^2 -values.*

Interaction	
AGE * SES * SEX * AID	2.75
AGE * SES * ACH * AID	13.36 *
AGE * SEX * ACH * AID	1.81
AGE * SES * SEX * ACH * AID	0.52

In table 14 there is only one substantial interaction - that between age group, socio-economic group, achievement and the recruitment effects of student aid. This is a natural result in the light of the G^2 -values shown in table 12. According to those values the interaction SES * ACH * AID was strong only within the youngest cohort, while all other interactions were weak.

In a way, it might be considered unnecessary to examine in detail the interaction AGE * SES * ACH * AID, since it is caused solely by the interaction shown in table 13. Nevertheless, we will do so, since such an examination will give a good summary of the change of the effects of student aid on social differences in transition rate during the period studied.

Table 15. *The influences of student aid on social differences in transition rate by age group and achievement level.*

<u>Students of high achievement level:</u>					<u>Students of low achievement level:</u>				
AGE	SES	AID	Difference	Effect	AGE	SES	AID	Difference	Effect
1948	I	.08	} - .15	- .08	1948	I	.08	} - .12	- .09
	II	.23				II	.20		
1953	I	.11	} - .03	+ .03 ¹⁾	1953	I	.08	} .00	+ .02
	II	.14				II	.08		
1963	I	.23	} - .05	+ .02 ¹⁾	1963	I	.14	} + .08	+ .09
	II	.28				II	.06		

1) The positive value of the effects does not mean that the aid has increased the importance of overall background. Since the corresponding difference is negative the positive effect value is to be interpreted as a weak effect.

Among students of high achievement, student aid was a powerful tool for counteracting social differences in transition rate in the late 60's. However, this positive effect decreased considerably during the early 70's even if it did not vanish completely, and from this time up to the early 80's, student aid has had a rather small socially equalizing effect.

Also among students of low achievement student aid counteracted the social differences in transition rate successfully in the late 60's. But, within this category of students the counteracting effect vanished completely in the early 70's and after that this development has continued so that, in the early 80's, student aid has become an instrument which strengthens social inequality.

In the light of these results, it is quite obvious that the recruitment effects of student aid have changed dramatically during the period of 15 years which has been studied in this report. It is also obvious, that radical alterations of the financial aid system are needed if, again, it is to be conducive to social equality of educational opportunity in transition from secondary to higher education.

Summary and discussion

The aims of this study are to answer the following three questions:

- I What are the general recruitment effects of student aid?
- II What are the selective recruitment effects of student aid?
- III Have these effects changed over the last 15 years?

By general recruitment effects is meant the extent to which student aid has increased the overall rates of transition to higher education. Selective recruitment effects refer to the question whether social differences and sex differences have been changed by the recruitment effects of student aid.

Three nationally representative samples of individuals born in 1948, 1953 and 1963 respectively are studied. By means of information about these individuals we have examined the role of student aid in transition from the upper-secondary school to higher education. Consequently, the study describes the situation in the the late 1960's, in the early 1970's and in the early 1980's.

During this period, the rate of transition from the upper-secondary school decreased considerably - from nearly 70% to less than 30. The most dramatic decrease occurred in the early 70's, but it has continued also during the following ten years up to the early 80's. The role played by the financial aid in this connection has varied. From the late 60's to the early 70's, the proportion of students recruited by the aid decreased, but only from 16% to 11, so during this period it is evident that student aid was a factor contributing to the decrease in transition rate. However, it is not the only factor and not even the most important one.

From the early 70's to the early 80's recruitment via student aid rose again so, at the end of the period, it reached the same level as in the late 60's. Still, the overall transition rate continued to decrease as mentioned above. Consequently, during this period, the overall transition rate and the recruitment effect of student aid have developed in opposite directions.

On the whole these results point to a fairly loose connection between student aid and transition rate.

If there had been a strong relationship the proportion of students recruited by student aid would have decreased during the last ten years too. Such a development would not have been unexpected in the light of the changes which have been made in the student financial aid system. Certainly, the possibilities to defray studies have not been changed to any great extent since the aid is linked to the cost-of-living index but the grant proportion has been reduced considerably - from 25% in 1965 to only 6% in 1985. Consequently, the debt which is the result of student aid utilization has grown tremendously. This change of the aid system has been most severe during the 70's and the early 80's, i.e. during the period when the recruitment effect of student aid has risen.

From these results it seems to be justified to conclude that the increasing debts have had no negative influence on the overall recruitment effect of student aid and that student aid is not to be blamed for the decreasing enrollment in higher education among young students. Instead, the causes of this are to be found elsewhere.

One important cause is those changes which have occurred on the labour market for people with a higher education. Around 1970, the future perspectives on this labour market deteriorated considerably. Higher education was no longer a guarantee of getting a job or getting high wages and the situation is still like that. Consequently, higher education has lost in attraction.

With an impaired student financial aid system and with a harder "recruitment climate" it seems justified to wonder why the recruitment effect of student aid has not decreased during the period studied. Does this mean that the aid has come to recruit new categories of individuals, people who previously entered higher education irrespective of student aid? If so, what have the consequences been for the social differences and the sex differences in transition rate?

As to the social differences, the results have shown that the effect of social background on transition rate has remained constant during the whole period studied. In each cohort the transition rate of students from higher social groups exceeds that of students from lower groups by about 15 units of percentage. This difference, itself, might be seen as relatively small but two circumstances must be taken into consideration. Firstly, the total cohort has been dichotomized, which reduces the differences compared to working with several categories and secondly, we are studying only those individuals who have entered the upper-secondary school, to which there has already been a very strong social selection.

In spite of an unchanged influence of social background on the actual transition rate, the effect of student aid in this connection has changed considerably. In the late 60's student aid had a substantial socially equalizing effect. If there had been no student aid available the social differences would have been twice as high as the actual ones. However, this positive effect vanished rapidly and, in the early 70's, student aid had practically no bearing on social differentiation. This change is very serious, seen in the light of student aid being one of the most concrete steps taken by the authorities in order to achieve social equality of educational opportunities.

However, during the next ten years the situation grew even more serious. In the early 80's, student aid was not only insignificant to social differences in transition rate but it even reinforced them. In fact, these differences had been increased by 3 units of percentage due to the recruitment effects of student aid.

The influences of student aid on social stratification have mainly affected the direct effects, i.e. the effect of socio-economic group on transition rate, sex and achievement being kept under control. However, within the youngest cohort, there is a small influence on the indirect effect of social background via achievement so that the total effect of social background is increased by 1 unit of percentage. So far,

this indirect effect has not caused any serious problems since it has been small. Nevertheless, it might be troublesome in the future, for there are clear tendencies that student aid has gradually strengthened the direct effect of achievement on transition rate at the same time as the social differences in achievement have increased between the two youngest cohorts. If these two tendencies continue, we will have a situation where the recruitment effects can be considered to be positive as well as negative at the same time. The situation is positive in so far as the aid helps to raise the ability level of the students in higher education, but, in doing so, the situation will be negative as to socially equalizing effects.

The effects of student aid on the social differences in transition rate discussed so far apply to the total cohorts. Within the two older cohorts these effects are valid for students of high achievement as well as for those of low achievement. However, among those born in 1963 the effects differ between these two categories of students. As a consequence, there is an interaction between age group, socio-economic group, achievement and recruitment effects of the aid, the meaning of which is shown in figure 6, below.

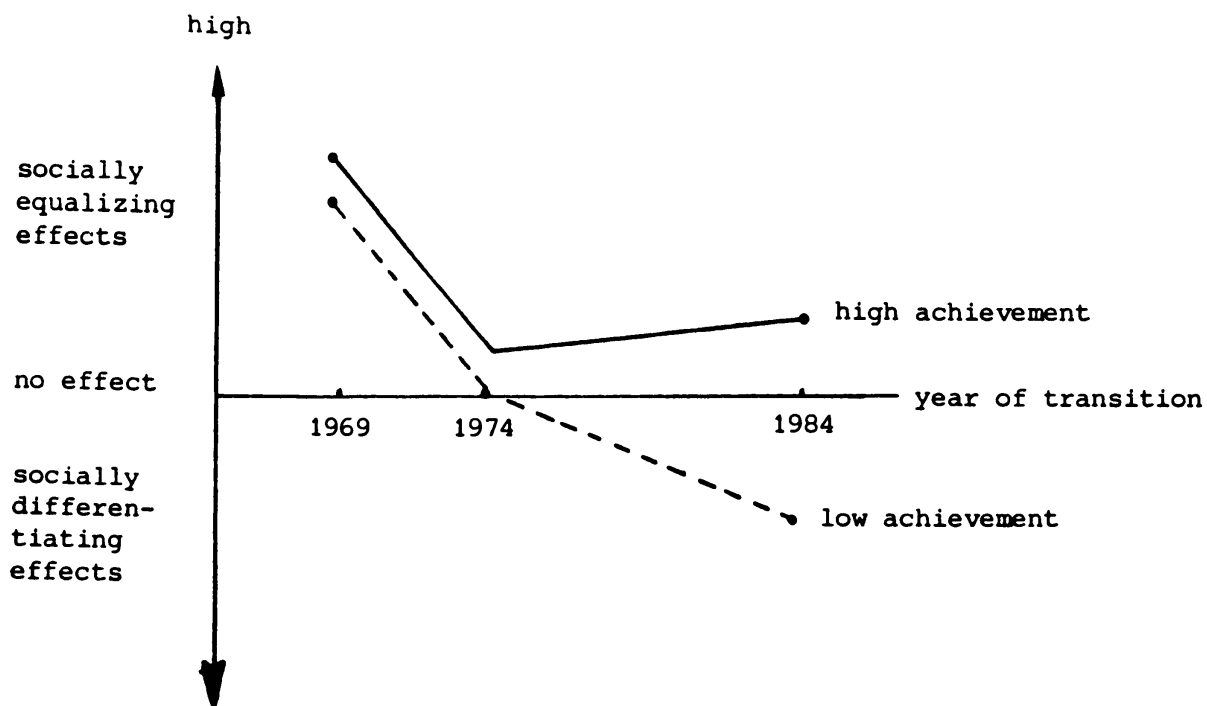

Figure 6. *The influence of student aid on social differences in rate of transition to higher education by achievement level.*

Figure 6 shows that the conclusion drawn about the decreasing socially equalizing effect of student aid during the early 70's is valid for students of both high and low achievement.

For the last mentioned group, this effect not only decreases, it vanishes completely before 1974 and 10 years later student aid has become a socially differentiating factor.

Among students of high achievement, the aid has counteracted social selection during the whole period, however, only weakly from 1974 to 1984. At the end of the period, its equalizing effect among high achievers falls below its selective effect among low achievers and this is the explanation of our finding that student aid has increased the social differences in transition rate within the total cohort, born in 1963.

These results confirm the hypothesis formulated earlier namely that there has been a change in the recruitment pattern of student aid. However, in order to understand these changes better we have to examine the actual proportions on which the trends in figure 6 are based. For the sake of simplicity we will show only those for the oldest and the youngest cohorts respectively.

Table 16. *The proportions of students recruited by student financial aid by socio-economic group and achievement level. Students born in 1948 and 1963 respectively.*

Socio-economic group: Achievement level:	<u>I</u>		<u>II</u>	
	High	Low	High	Low
Students born in 1963	.23	.14	.28	.06
1948	.08	.08	.23	.20
Difference	+.15	+.06	+.05	-.14

In order to account for the changes shown in table 16, we have to take into consideration, among other things, those two developments mentioned before, namely deteriorating future prospects on the labour market and the impairment of student aid. Concerning deteriorating future prospects, the situation is particularly trying for students who have finished a program within the faculties of arts and social sciences and these programs are mostly chosen by students from lower social strata (Svensson, 1981). Furthermore, these programs had open admissions at the time when the two oldest cohorts entered higher education. For the youngest cohort, admission to these programs had been restricted but the admission requirements were still relatively liberal in comparison with those of the more prestigious programs.

These changes (together with the impaired student aid system) are the main causes why the proportion of students of low achievement from group II recruited by student aid has decreased during the period studied. They also account for the fact that the change in recruitment effect has developed less favourably among students of low achievement than among those of high achievement within socio-economic group I.

However two trends in table 16 cannot be accounted for by means of the factors mentioned here. The first is the fact that the recruitment effect has developed more favourably for students from higher social strata irrespective of achievement level. The second is that the proportions of students recruited by student aid have increased for three categories of students out of four.

Concerning the more favourable development for students from higher social strata Svensson (1985) has shown that they do not fear future debts as much as those from lower social strata. Consequently, they have not regarded the impairment of the aid to be as severe as have students from lower social strata.

The fact that the recruitment effects of student aid have increased irrespective of achievement level within group I and for students

of high achievement in group II should be seen in the light of the general economic development during the 70's. In Sweden, like most other Western countries, there has been economic recession and relatively high inflation. Therefore, higher education has brought about increasing economic sacrifices for the individual and for his/her family. Therefore, student aid has grown more important to those who have entered higher education. This is shown by the fact that the proportions of students who have been able to enter higher education thanks to the aid have risen from 25% in the late 60's to 60% in the early 80's. Consequently, at the same time as student aid has become more important to students *in higher education* it has lost its power as a socially equalizing instrument in transition *to higher education* and, instead of recruiting primarily students from lower socio-economic groups, as was originally intended, the aid has come to recruit primarily students from higher social strata.

On the whole, sex differences in transition rate are much smaller than are differences between socio-economic groups. Nevertheless, they show an interesting development pattern. During the late 60's and early 70's, men's transition rate exceeded that of women by a few units of percentage, but later sex differences have changed to the advantage of women.

To some extent, this changed pattern is caused by the student aid. Certainly, the aid has mainly recruited women to higher education during the whole period studied and in doing so it has counteracted the sex differences in transition rate during the late 60's and early 70's. But, in the early 80's, there would not have been any sex differences at all, if no student aid had been available. This is caused by the fact that achievement has come to influence the transition rate more and the fact that women are higher achievers. Consequently, the indirect effect of sex on transition rate via achievement, which is to the advantage of women, has balanced the direct effect, which is to the advantage of men.

As said before, student aid has recruited women mainly. In doing so, the aid has reduced the direct effect of sex on transition rate and, moreover, the aid has strengthened the indirect effects via

achievement. These two influences together result in a sex difference transition rate to the advantage of women within the youngest cohort.

After having discussed these results we are now facing the inevitable question of what should be done with the student financial aid system. This is, by the way, a question that a newly appointed government commission will also have to answer.

Before trying to answer that question it is necessary, however, to state what are the most important aims of the system. In Sweden these aims are:

- to facilitate transition to higher education
- counteract differences in transition rate between men and women, different socio-economic groups, different regional groups, etc
- to give the students a decent standard of living during studies so that they have the possibility to complete their studies within a reasonable time.

Of course, all these aims can not possibly be treated in one report so we have chosen to examine the effects of student aid on sex differences and on social differences for young students. Consequently, the proposals which will be made here must be seen with reference to these restrictions. If we had chosen to study another aim, for instance, the third mentioned above, it is very likely that the proposals would have been different.

With our restricted perspective and in the light of the empirical findings of this report, we think that the most urgent problem is to make student aid the socially equalizing instrument which it was intended to be. In order to achieve this goal, the aid will have to

be changed so that the recruitment effect is increased within lower social strata and/or decreased within the higher ones. Furthermore, in the light of the results found these changes will have to be considerable.

Can these changes possibly be achieved by making the aid more attractive, for instance, by offering more money to each student, by rising the grant proportion of the total sum or by making the repayment rules more liberal?

Probably these alterations of the system will only have small effects on social selection. Certainly, students from lower social strata are more reluctant to incur debts, but making the aid more attractive inevitably brings about an increased recruitment of students from higher socio-economic groups, too. Furthermore, these alterations of the aid are not likely to be made since the government has stated that a reformed financial aid system must not increase the total expenditure. Only a redistribution of the money now available is allowed.

With these restrictions, it seems to us that the only way to achieve a socially equalizing effect is to make the aid system selective. By this we mean that the system should be designed in such a way that, in the first place, students in great need of economic support should be offered the aid and receive an amount of money that would ensure them a decent standard of living. At the same time, the grant part should be increased and the repayment rules should be designed in such a way that debts will not act as a deterrent.

Unfortunately, these alterations of the system are not very likely to be accomplished since there is a very determined political resistance in Sweden to making the aid system selective. Therefore, it is hardly an exaggeration that one of the most difficult problems of the commission is how to make the student financial aid an effective means in the efforts of achieving greater social equality in educational opportunity.

REFERENCES

- Anderson, C.A. Expanding Educational Opportunities: Conceptualization and Measurements. Higher Education, 1975, 4, 393-408.
- Baker, F.B. Log-linear Models: A Didactic. Journal of Educational Statistics, 1981, vol 6, 1, 75-102.
- Bishop, Y.M.M., Fienberg, S.E. & Holland, P.W. Discrete Multivariate Analysis - Theory and Practice. Cambridge, MA: Institute of Technology Press, 1975.
- Blaug, M. & Woodhall, M. Patterns of Subsidies to Higher Education in Europe. Higher Education, 7, 1978, 331-361.
- Everitt, B.S. The Analysis of Contingency Tables. London: Chapman and Hall, 1977.
- Hellevik, O. Kausalanalyse av krysstabeller. Oslo: Universitetsförlaget, 1980.
- Härnqvist, K. & Svensson, A. A Swedish Data Bank for Studies of Educational Development. Sociological Microjournal, 7, 1973, 35-42.
- Noonan, R. & Elggvist-Saltzman, I. Some Notes on Comparing Changes in Educational Enrollment and Transition Rates. Scandinavian Journal of Educational Research, vol 26, 1, 1982, 141-160.
- Reuterberg, S.E. Study Assistance and Degree Completion in Higher Education. Reports from the Department of Education, University of Göteborg, no 1983:4.
- Reuterberg, S.E. Studiemedel och rekrytering till högskolan. Acta Universitatis Gothoburgensis, 1984.
- Reuterberg, S.E. On Comparing Transition Rate Gains. Scandinavian Journal of Educational Research, vol 29, 4, 1985, 175-190.
- Reuterberg, S.E. & Svensson, A. The importance of Financial Aid: The Case of Higher Education in Sweden. Higher Education, 12, 1983, 89-100.
- Svensson, A. Jämlikhet i högskolan - fiktion eller realitet? UHÄ-rapport 1981:25.
- Svensson, A. Högskolestudier - attraktivare för kvinnor? UHÄ: projektrapport 1985:1.
- Woodhall, M. Student Loans: Lessons from Recent International Experience. London: Policy Studies Institute, 1982.

APPENDIX I

Group sizes

Socio-economic group	Sex	Students born in		
		1948	1953	1963 ¹⁾
I	Men	459	527	6,714
	Women	400	466	5,094
II	Men	708	762	9,184
	Women	641	691	9,367
Total		2,208	2,446	30,359

1)

The 1963 group sizes have been adjusted to population numbers because of the sampling method. The actual number of individuals in the sample is 2,234.

APPENDIX II

An example of calculating direct effects

In the example the direct effect of social background (SES) on transition rate is calculated within the 1948 cohort. The result refers to figure 4 and table 5 in the report.

SES	SEX	ACH	TR	EFFECT
I	Men	High	.84	.18 .18 .13 .10
		Low	.76	
	Women	High	.83	
		Low	.64	
II	Men	High	.66	
		Low	.58	
	Women	High	.70	
		Low	.54	
Direct effect of SES				.15

Weighing the subgroup effects

Subgroup		Effect	Weight factor	Weight	Weighed effect
Men	High	.18	$\frac{224 \cdot 320}{544} = 131.76$.251	$.251 \cdot .18 = .045$
	Low	.18	$\frac{235 \cdot 388}{623} = 146.36$.279	$.279 \cdot .18 = .050$
Women	High	.13	$\frac{221 \cdot 368}{589} = 138.09$.263	$.263 \cdot .13 = .034$
	Low	.10	$\frac{179 \cdot 273}{452} = 108.11$.206	$.206 \cdot .10 = .021$
Sums:			524.31	1.000	.150

The weight factors are calculated from the number of individuals in the two subgroups compared. Consequently, the weight factor for "men high" is calculated from the number of men with high achievement in socio-economic group I and II respectively. The weight for this subgroup effect is given by dividing its weight factor by the sum of weight factors.

APPENDIX III

The interpretation of interactions

The example is taken from table 8 where we interpret the interaction SEX*ACH*TR among students born in 1963. According to the G^2 -values in table 6 this interaction is significant on the 5%-level ($G^2 = 4.52$).

SES	ACH	TR actual	TR predicted	Difference:		Effect
				actual	predicted	
I	High	.53	.55	▷ .14	▷ .18	-.04
	Low	.22	.19			
II	High	.39	.37	▷ .13	▷ .09	+.04
	Low	.09	.10			

As we have said on page 9 the actual frequencies on which the proportions are calculated can be reconstructed exactly by the saturated model. In this case the saturated model reads:

$$F = GM + SES + ACH + TR + SES*ACH + SES*TR + ACH*TR + SES*ACH*TR$$

If, instead, the frequencies are calculated by a model which does not include the interaction SES*ACH*TR, we will receive a set of frequencies describing the situation where there is no interaction present. This situation is shown by "TR predicted" in the table above. On the basis of these proportions we can calculate the predicted differences under the assumption of no interaction. By comparing the actual and the predicted differences we receive a measure showing the interaction effect.

The reason why this effect is strongest among students of low achievement is the fact that the actual transition rate is rather low in this group. Consequently, the difference of 0.13 occurs in a more extreme part of transition rate curve than does the difference of 0.14 among students of high achievement.

PUBLIKATIONER FRÅN INSTITUTIONEN FÖR PEDAGOGIK,
GÖTEBORGS UNIVERSITET

issn 0282-2180

Beställes från Institutionen för pedagogik, Göteborgs universitet, Box 1010, 431 26 Mölndal.

Krokmark, T. Livsvärlden. Noteringar på vägen mot en ontologi för fenomenografisk forskning. (Fenomenografiska notiser 2.) 1986:01.

Krokmark, T. & Marton, F. (Red) Individernas förutsättningar för utbildning och utbildningens effekter på individerna. Ett symposium tillägnat Kjell Härnqvist. 1986:02.

Krokmark, T. Inläring som omläring. 1986:03.

Krokmark, T. & Rödén, D. (Red) Studier i stadiedidaktik. Symposierapport. 1986:04.

Förteckning över tryckta skrifter publicerade 1984-1985. 1986:05.

Ihde, D. On non-foundational phenomenology. (Fenomenografiska notiser 3.) 1986:06.

Marklund, U. Droginformatörsutbildning i en enskild skolas regi. (Projekt "Elever som droginformatörer", Rapport 4.) 1986:07.

Marklund, U. Vänskapsmönster i årskurs åtta. (Projekt "Elever som droginformatörer", Rapport 5.) 1986:08.

Ågren, B. På väg mot en samhällsintegrerad förskola. Utredningar och debatt om barnomsorgen i Sverige. 1986:09.

- Ågren, B. "Överlägsen på alla områden!" Föräldrar och personal om den gemensamma allmänna förskolan i Ale kommun. 1986:10.
- Krokmark, T. Tre ansatser till inlärningsforskning i Israel. 1986:11.
- Krokmark, T. Vad är didaktik? 1986:12.
- Krokmark, T. Etikett och innehåll. En studie i grammatikundervisningens villkor. 1986:13.
- Stukat, K.-G. & Bladini, U.-B. Svensk specialundervisning - intentioner och realiteter i ett utvecklingsperspektiv. 1986:14.
- Pramling, I. Meta-inläring i förskolan. Förskolebarns uppfattningar av inläring och av innehållet i temat "Affären". 1986:15.
- Reuterberg, S.-E. & Svensson, A. Student financial aid and participation in higher education. Changes between 1965 and 1985 in Sweden. 1986:16.
- Reuterberg, S.-E. Orsaker till studieavbrott och linjebyten i gymnasieskolan. 1986:17.

