

Flexible cushions for wheelchair users

Noriko Tanaka

School of Design and Craft, University of Gothenburg
Gothenburg
2011

Degree Project 30HECs, Fine Arts Master' s Programme in Design 120 HECs

Tutor : Ian Gront
Examiner : Henning Eklund
Opponent : Carl Hampf

ABSTRACT

For many wheelchair users, pressure sores are an unavoidable chronic physical disorder. As well as healing wounds, preventing the disease is a vital issue, and the wheelchair cushion is one of the most important aids for taking care of the sore.

However, the wheelchair cushions and other cushions to support physically disabled people of today ' s market still have many problems.

Due to hygiene issues and prevention of the sore, it is important to change the where one sits down, as well as to change and wash the cushion frequently.

Wheelchair users must continue to sit on the cushion for a long time even if it the cushion has many problems, since ordinary sofas and chairs do not give enough support.

I defined that the wheelchair, sofa and car/airplane seats are the most important places for wheelchair users to enjoy a more active life and thus created new types of cushions to alleviate the problems encountered in these areas.

Keywords : medical issue / physical disabled / wheelchair / cushion / pressure sore

FOREWORD

I would like to express my deepest thanks to Mr. Kenichiro Kano at TOYOBO. CO. Ltd., (sponsor company for BREATHAIR) for his support and generosity.

I would also like to especially thank all the wheelchair users who interviewed with me and my advisers Baldur Gudnason, Lena Bengtsson and Agneta Sundgren.

TABLE OF CONTENTS

INTRODUCTION	4
BACKGROUND	4
MEDICAL BACKGROUND	4
PRESSURE SORE	4
WHEELCHAIR CUSHION STUDY	6
IMPLEMENTATION	7
INTERVIEW	7
IDENTIFIED PROBLEM	7
RESULT OF THE INTERVIEW	7
FORMULATION OF THE PROBLEM	8
AIM AND GOAL	8
RESULTS	9
TARGET	9
● CUSHION FOR WHEELCHAIR	9
MATERIAL	9
● CUSHION FOR TRANSPORTATION SEATING	14
● CUSHION FOR SOFA / CHAIR	16
DEVELOPMENT	19
POSSIBILITY AS A PRODUCT	19
REFLECTIONS	20
SOURCES	21
APPENDICES	22

INTRODUCTION

For many physically disabled people, wheelchairs are one of the essential helping aids that support their daily lives. The wheelchair itself is undoubtedly the primary device, however, the tools which are incidental to the wheelchair are also quite important. These items tend to be less well represented, but the wheelchair doesn't work without them.

Wheelchair cushions are a representative of this type of product.

However, the wheelchair cushion of today's market still has many problems. In this project, I propose a new possibility for wheelchair and other cushions to support physically disabled people.

BACKGROUND

MEDICAL BACKGROUND

For the government, the escalation of medical expenses is a serious issue.

In advanced countries, medical costs related to the aging population are increasing. The illnesses which are caused by physical debilitation due to aging, and long periods of bad spine position caused by laying in beds due to illness provoke the outbreak of many kinds of disorders. One of the most serious disorders is pressure sore.

There are other reasons for the outbreak of pressure sores. Long periods of wheelchair usage can also trigger the disease.

The two main reasons for using a wheelchair are physical disability and disability caused by sickness or by some kind of accident, such as a traffic accident. In particular with the latter case, being sick or becoming involved in an accident and being stricken with a physical disability as a result could happen to anyone. Therefore, helping aids such as wheelchairs are not something that can be ignored.

For many wheelchair users, pressure sores are an unavoidable chronic physical disorder. Recovery needs long-term healing and many operations. It requires huge medical and manpower expenses.

In addition to healing wounds, preventing the disease is a vital issue, and the wheelchair cushion is one of the most important aids for taking care of the pressure sore. Prevention surely plays a part in the effort to reduce medical costs, and it helps create balanced medical expenses that help everyone experience better medical service.

In addition to healing wounds, preventing the disease is a vital issue, and the wheelchair cushion is one of the most important aids for taking care of the pressure sore. Prevention surely plays a part in the effort to reduce medical costs, and it helps create balanced medical expenses that help everyone experience better medical service.

PRESSURE SORE

The cause of the outbreak of a pressure sore can be divided into two main classes, internal factors and external factors.

The internal factors cover a broad range of elements such as aging, malnutrition, paralysis and xeroderma. External factors include stress which is applied to the inner tissue to act against the external forces. The stress on the contact portion between the body and supporting surface such as a bed is divided into two types. One is compression stress which is generated by the stressful actions in a vertical direction against the tissue. Another is stretching/shear stress which is caused by friction between the tissue and supporting surface.

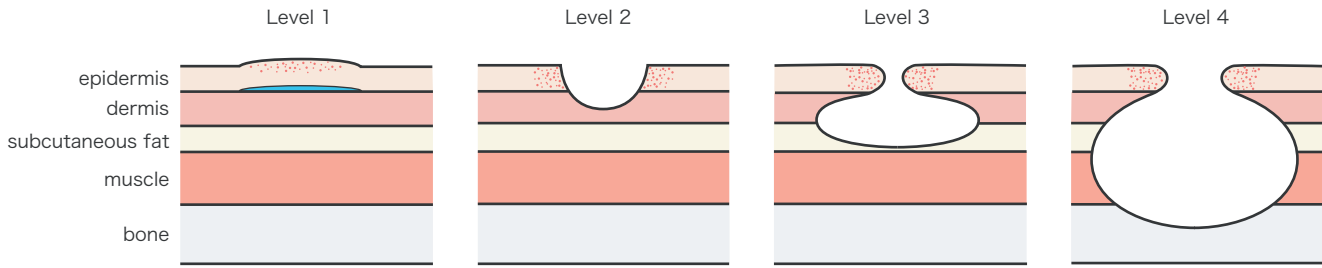

Picture 1 Acuteness of pressure sore

The pressure sore can be divided into the accidental (idiopathic) sore and the chronic sore. The former one forms on healthy individuals as a result of temporary external stress and if the stress is released, the wound is cured immediately. In contrast, the latter case is a chronic course and is intractable. It tends to appear commonly within the patient group in which there is some factor that could contribute to delayed healing. The pressure sore which wheelchair users have is the latter case.

The acuteness of pressure sores is categorized into 6 stages. Picture 1 above shows the acuteness of the wound from level 1 to level 4. (In the 6 stages, the first stage is a sign of the sore such as skin discoloration or a blood blister. The last stage is the extremely serious condition which is an unmeasurable level of the depth.)

In the level 1, the epidermis becomes excoriated and/or local redness appears.

In the level 2, the depth of the sore reaches the dermis and forms a skin ulcer. Sometimes it develops into a blister and it tends to trigger adherent dead tissue or a bacterial infection.

In the level 3, the defect extends to the subcutaneous tissue.

And in the level 4, the ulcer damages the muscle and the bone. Sometimes it causes bone necrosis, osteomyelitis and/or sepsis.

As the picture shows, as symptoms progress, the wound site hypertrophies, and in the end it reaches the muscle and the bone. It is extremely difficult to cure and the patient needs an operation to fully covered from this state of the wound. The problem is not the wound itself but that the transmission potential of the wound can create a fatal case. The most common cause of death amongst people who have pressure sores is not bleeding or tissue necrosis, but the infectious disease caused by the wound.

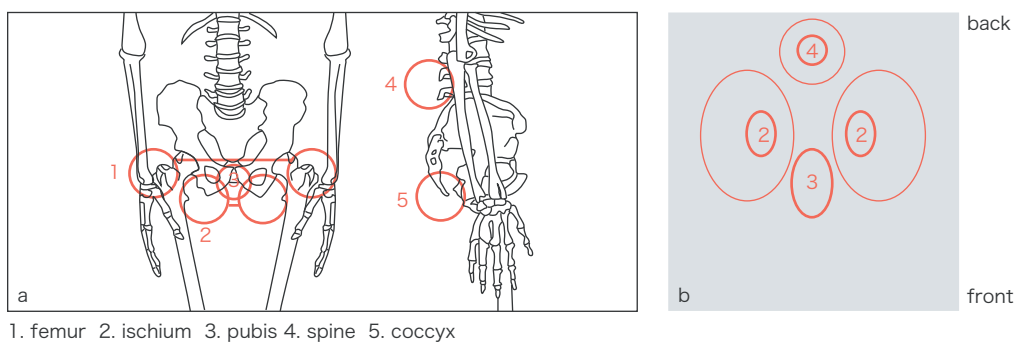





Picture 2 frequent pressure sore occurrence areas due to usage of wheelchair

Picture 2-a above shows the frequent pressure sore occurrence areas of wheelchair users. In part 1, the femur touches the side guard and in part 4 the spine touches the back support. Part 2, 3 and 5 touch the seating face. As the picture 2-b shows, the stresses onto the seating face are not regular. The areas beneath the bones face the strongest levels of stress and the area around the bones also experiences pressure. More or less, these areas and stresses can be transmuted depending on the patients' posture habit, weight, body size and the condition of the sore if the patient is injured.

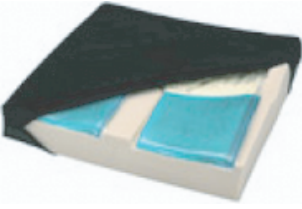
WHEELCHAIR CUSHION STUDY

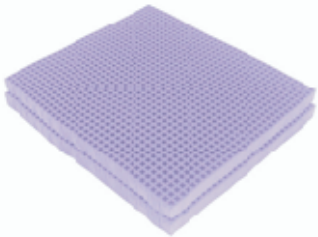
The list 1 below is classification of common wheelchair cushions in the market today.

Picture			
	1	2	3
Name	ROHO cushion	Gel cushion	Air cushion
Material	Gum elastic, Air	Gel (with other material)	Toughened nylon, Acrylic, Air
Average weight(kg)	1.3 - 1.5 kg	1.7 - 1.9 kg	0.8 - 1.0 kg
Average price(SEK)	4500 SEK	4500 SEK	4000 SEK
Picture			
	4	5	6
Name	Urethane cushion	Geltron cushion	Honeycomb cushion
Material	Urethane	Geltron(Mineral oil, Polymer)	Thermoplastic Urethane
Average weight(g)	0.5 - 0.7 kg	1.3 - 1.5 kg	0.5 - 0.7 kg
Average price(SEK)	1000 SEK	1500 SEK	5000 SEK

List 1 Wheelchair cushions

1 ROHO cushion

The ROHO cushion is the most popular cushion for seriously disabled people. The air contained in gum elastic has high liquidity and it distributes body pressure effectively. Since the material is completely unbreathable, the skin surface that touches the cushion tends to be damp. Gum elastic is soft, thus air leaks when it is ruptured. And the cushion becomes much harder in airplanes due to pressure change.

2 Gel cushion

The gel cushion consists of several layers. Often, the top is gel and the bottom is hard urethane. Gel also has high liquidity and pressure distribution like the ROHO, but is quite heavy and unbreathable. Since urethane on the bottom is solid, this cushion does not have high bendability.

3 Air cushion

As the name shows, air cushion also contains air like ROHO. But this cushion consists of several large pockets which contain many small air bags, so even if a bag breaks it can be fixed easily. The bags make a sound when the user moves.

1 <http://www.therohogroup.com/popup.jsp?Title=MID%20PROFILE%20QUADTRO%20SELECT%20CUSHION&Image=d2-quadro>

2 http://www.francebed-ms.com/item/item_00163.html

3 <http://www.vicair.com/oudeite/index.htm>

4 http://www.invacare.com/cgi-bin/imhqprd/inv_catalog/prod_cat_detail.jsp?prodID=EC

5 <http://www.jsleep.com/care/caringcushion.html>

6 <http://www.spinalistips.se/tips-stimulite-en-979.html>

4 Urethane cushion

Urethane cushion is the most popular cushion who do not face a high risk of pressure sore. This cushion has many different hardness, light, inexpensive and can be formed into required shape if it is thick. But soft urethane can be pressed and can not hold the shape after long-term usage.

2 Geltron cushion

Geltron cushion is commonly used to elderly people. The weight in the list is when it is 3.5cm and the cushion for disabled people should be around 5 to 10 cm and if this cushion is in that thickness it is clearly too heavy.

3 Honeycomb cushion

The structure of this cushion is quite unique. Many thin plastic plates with small holes construct honeycomb structure and it allows air to pass through easily. The cushion is lightweight but hard and has no bentability.

IMPLEMENTATION

INTERVIEW

The interviews about usability of wheelchair cushions were conducted with 14 wheelchair users ages 18 to 53, 9 males and 5 females, with the aid of 3 professionals; a helper, a physical therapist and a assistive device coordinator who worked around the interviewees.

IDENTIFIED PROBLEM

RESULT OF THE INTERVIEW

A single interview with a wheelchair user consists of 15 basic questions and other questions depending on the questionee's condition. Graphs 1 to 5 below show the results of measurable questions. The details of the questionnaire are described in Appendix 1 on page 22.

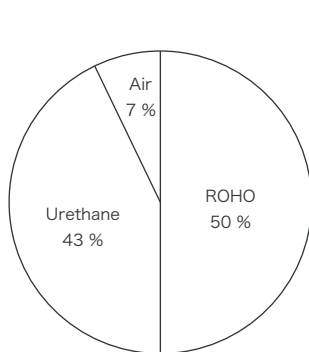

Graph 1 (Q.1)
Type of currently-used cushion

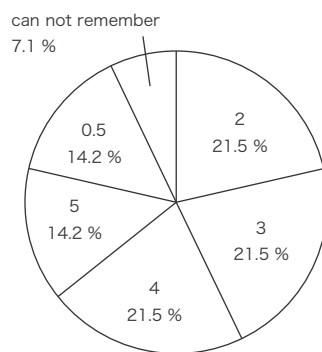

Graph 2 (Q.2)
Age of the cushion (year)

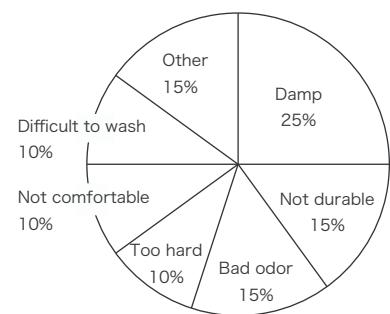

Graph 3 (Q.4)
Problem of currently-used cushion (multiple answers allowed)

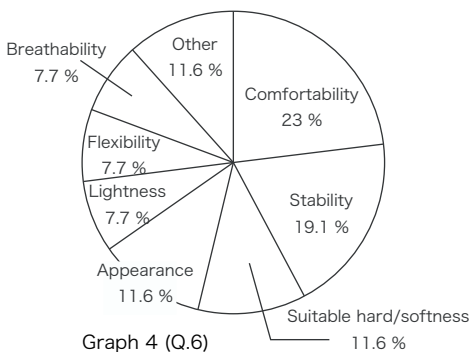

Graph 4 (Q.6)
Important things for wheelchair cushion (multiple answers allowed)

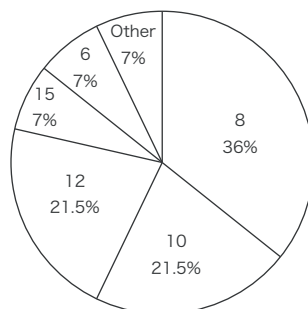

Graph 5 (Q.13)
Sitting hours a day

Important keywords for the wheelchair cushion which all professionals mentioned strongly were:

- Customizable / Make the cushion possible to be customize to the body scale of different users.
- Suitable material / It's very important to pay attention to the material for the cushion cover as well.
- Stability
- Comfortability

FORMULATION OF THE PROBLEMS

● General problems of the wheelchair cushions

The most striking point of the cushions is the price. The most common cushions for serious injuries (ROHO cushion, gel cushion) cost about 4,000 - 4,500 Swedish crowns. Due to hygiene issues and prevention of the sore, it is important to change and wash the cushion frequently. However, the price discourages people from having many cushions. Also, the cushions all look alike and there is no ability to choose differently. There is a need for various choices.

● The problems of the wheelchair cushions the users mentioned

Generally, the wheelchair cushion consists of non-breathable materials such as elastic, gel, plastic or urethane. From a clinical standpoint, to prevent the pressure sore, it is necessary to keep the skin away from damp conditions such as exposure to urine and sweat. This characteristic of the materials contributes to the outbreak of pressure sores. In interviews, "Damp" was the most common answer to the question "Problem of currently-used cushion". In addition, the most common answer of the question "Important things for wheelchair cushion" was "Comfortability". This result indicates that the solution material should be something breathable. Moreover, the users mentioned the bad odor of the cushion as well. As described above, to be washable is a requirement. To make the cushion washable solves this problem.

● The problems of the wheelchair cushions the professional people mentioned

Every users have different body scales, weights and posture habit. Sometimes it is quite difficult to figure out the right cushion.

AIM AND GOAL

The aims of this project are

- To propose a way to prevent pressure sores
- To propose new usage of cushions for physically disabled people.
- To make the cushion more useful.

Decreasing the physical and mental strain of wheelchair users and people who need this kind of product to enjoy a more active life, thus improving the quality of their lives.

The wheelchair users must continue to sit on the cushion for a long time even if it has many problems, since ordinary sofas and chairs do not give enough support. It is important to change the place where they sit down during the day. The wheelchair cushion is constantly advancing but other places to sit and the ideas about how to cater to disabled people tend to be ignored.

Normally in daily life, people sit down in many places in different situations, for example: desk chair, car seat, sofa, deck chair, and dining chair etc. However, most of the times wheelchair users sit down only in a wheelchair. The wheelchair could be called their legs and it can not be separated from them, but it also means they cannot sit down in the train or sofa at home with their friends and family. The number of choices for where to sit down should be numerous, like for other people.

Therefore, it is important not to propose only a wheelchair cushion but also to take a look at the entire life of wheelchair users.

I defined that the wheelchair, sofa/chair and transportation seats are the most important places for wheelchair users to enjoy a more active life and have designed a new type of wheelchair cushion and other cushions to alleviate problems.

RESULTS

TARGET

From the interview, many wheelchair users said that the cushion for the most serious disabled people can also be good for other users. Thus, I decided that the target group includes spastic people, those with spinal cord injuries and those suffering from brain paralysis.

CUSHION FOR WHEELCHAIR

This is the main product for this project.

MATERIAL

Selection of material was one of the most important themes in this project. From the keywords that I discovered in interviews, I found out the quite suitable material BREATHAIR which is developed by TOYOBO CO., LTD. in Japan. This material fulfills all the required conditions. And to create something new, I adapted the material known as Powder Beads which has not yet been introduced to the Swedish market yet.

Key words

<Hygienic> breathable, washable

<Stable> spongy

<Comfortable> breathable, lightness, preventive

<User friendly> inexpensive, eco-friendly, durable

BREATHAIR (for the main part)

Primary material : Polyester

Character : Many different densities and hardnesses



High compressive resilience

Durable

Clean (Washable)

Antibacteria

Breathable

Light

Recyclable

POWDER BEADS (for the cover)

Primary material : Expanded polystyrene

Character : High liquidity

Pressure dispersion effect

Clean (Washable)

Breathable

Light

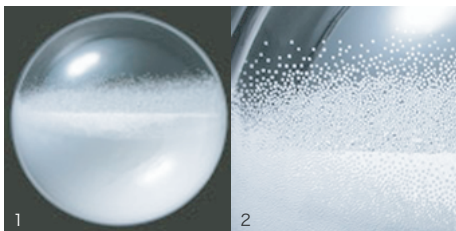



1 <http://www.mogulax.jp/html/newpage.html?code=6>

2 <http://www.mogus.jp/beads/>

● Appearance



● Function

-  100% hard
-  80% hard
-  60% hard

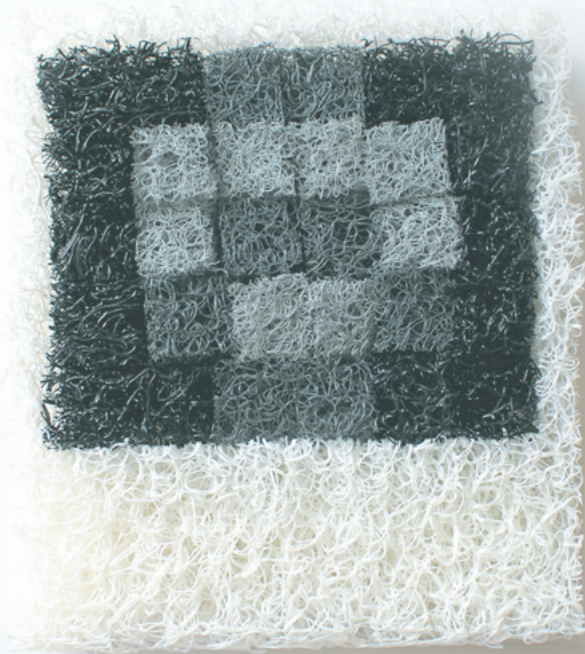
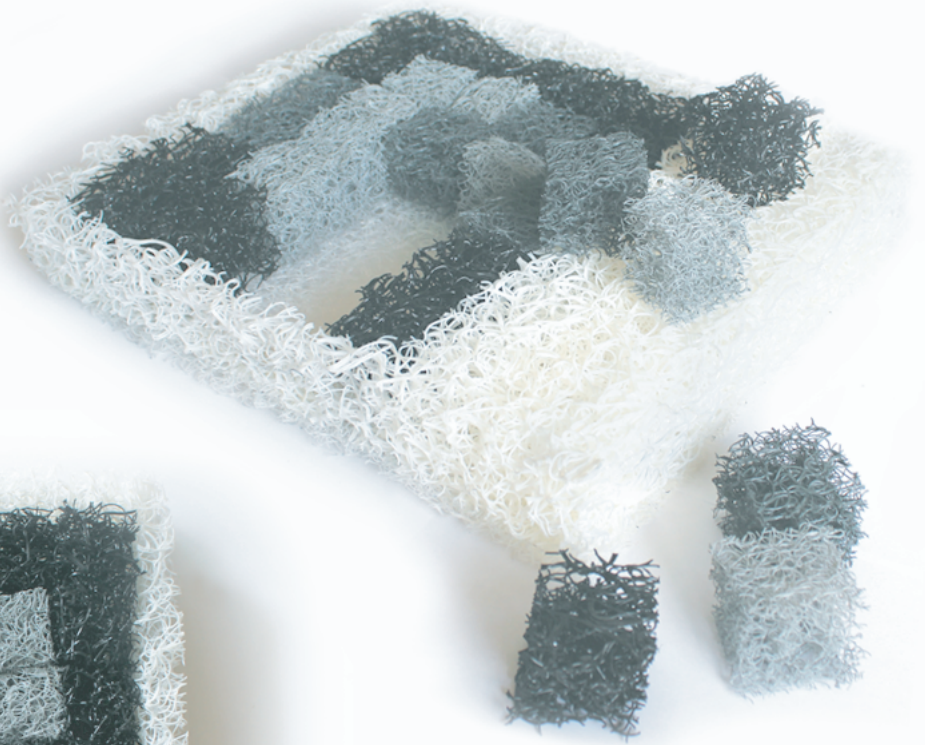

BREATHAIR cubes which are arranged under the bottom are colored depending on their hardness. The darkest is the hardest and the lightest is the softest.

Everybody has a different size and shape of backside and the condition of pressure sores is always changing.

The gradation of BREATHAIR cubes make the user easily understand what areas are hard and soft so they can adjust the layout for comfortable seating by themselves. When the cushion becomes dirty, the cubes can be changed and washed.

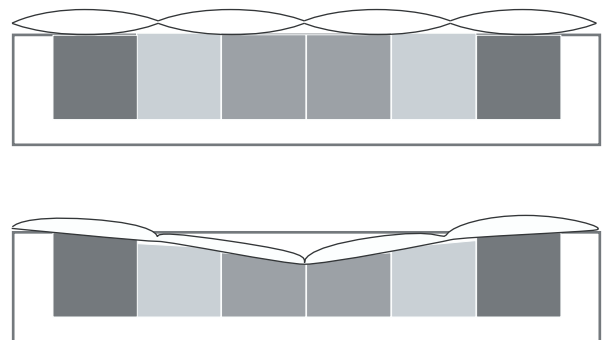

Picture 3 Powder Beads flatten the surface of the blocks

When the cushion is pressed, the cubes make bumps on the surface. As picture 3 shows, the Powder Beads on the cover flatten these bumps and hold the breech softly giving stability.



As with the size of backsides, everybody has a different size and shape of back. This back cushion has pockets and it is possible to customize the inner cushion depending on the needs of the user. Along the spine is one of the most frequent spots for pressure sores to occur on the body, thus the center of this cushion has no cushion and does not touch the back. The plain appearance fits into all types of wheelchairs.



● Size

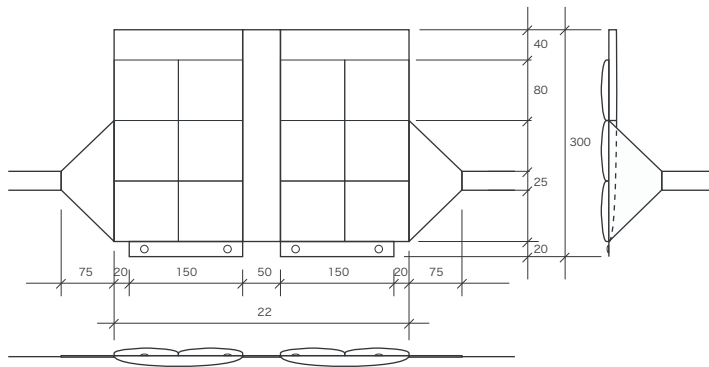

<back cushion>

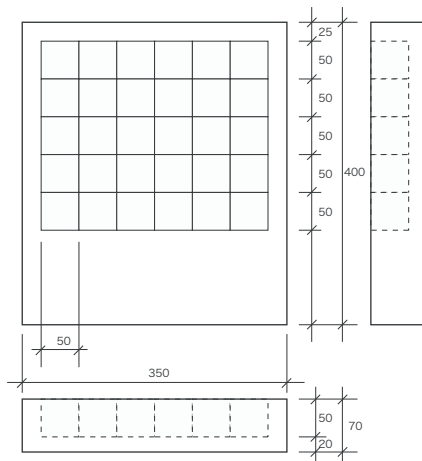

<inner>

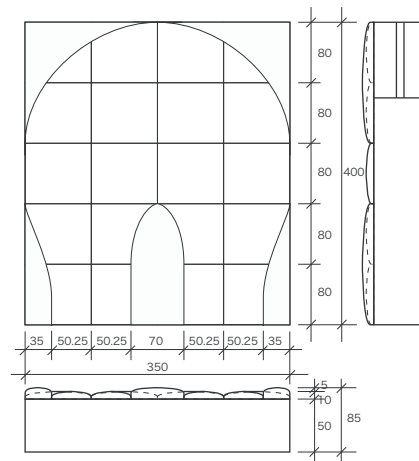

<cover>

[1:10]

● Trial fitting



CUSHION FOR TRANSPORTATION SEATING

To enjoy an active life and going outside of their home, people need to use transportation. However, normal seats are never soft enough for the bottom which has a wound, and ROHO cushions become much harder and do not work when subjected to air pressures changes on airplanes. Many wheelchair users mentioned that they want something else for these seats.

● Appearance



● Function



Holding system enables the cushion to be carried as normal baggage.

The surface material has a very common appearance and this simple color and shape fit into many transportation seats.

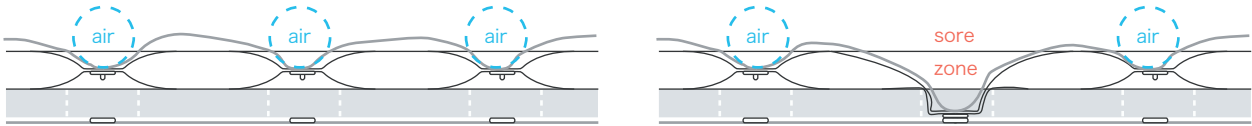
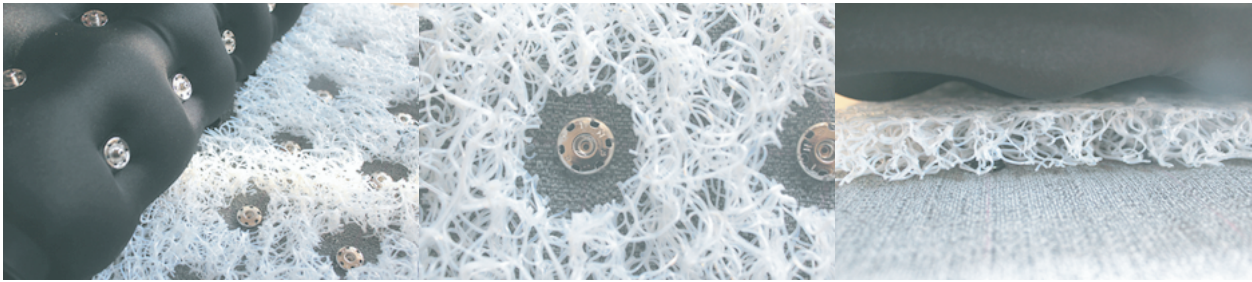

normal

dent

deep dent

This cushion also consists of spandex which contains powder beads inside and the BREATHAIR material. Many indentations in the spandex area keeps users' backsides dry and comfortable. The back of the surface fabric contains many buttons and when fastened, the indentations become larger and deeper so that the cushion doesn't touch the sore.

● Size

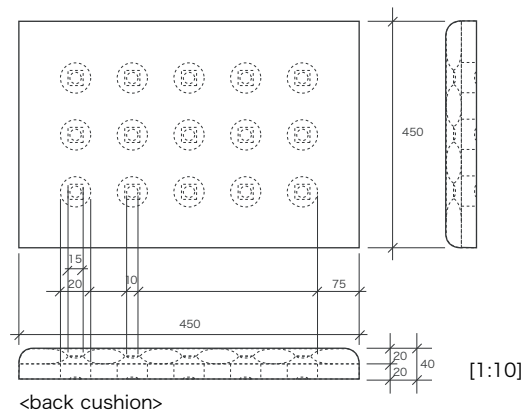
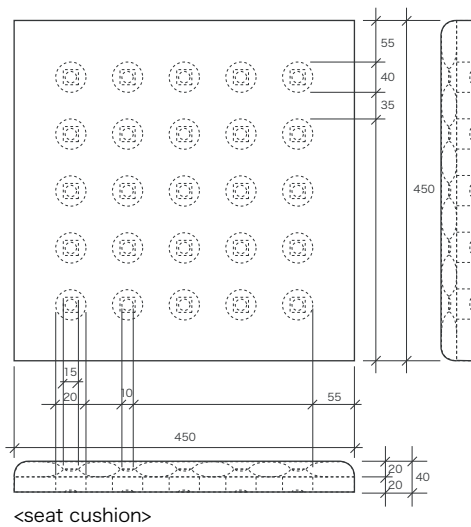

[1:10]

CUSHION FOR SOFA / CHAIR

Due to hygienic issues, it is better to change the seat frequently and is quite important to have somewhere to feel relaxed while at home.

The sofa is an important space for family life at home. If the sofa is not soft enough, wheelchair users cannot sit down with their family to enjoy spare time.

● Appearance



● Function

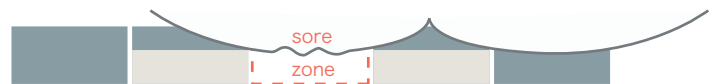
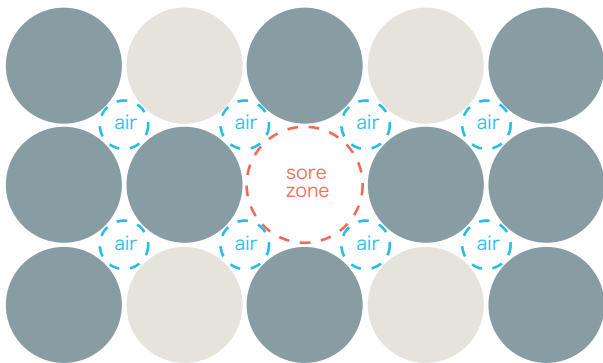

Small cushions have velcro tape on the back and can connect to other cushions. The spaces between cushions make a more breathable condition between the hip and seating surface.

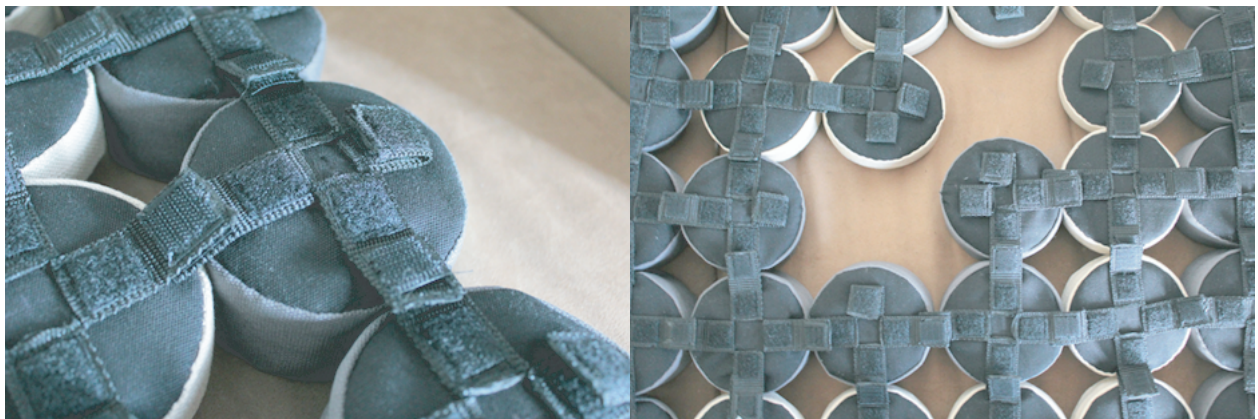

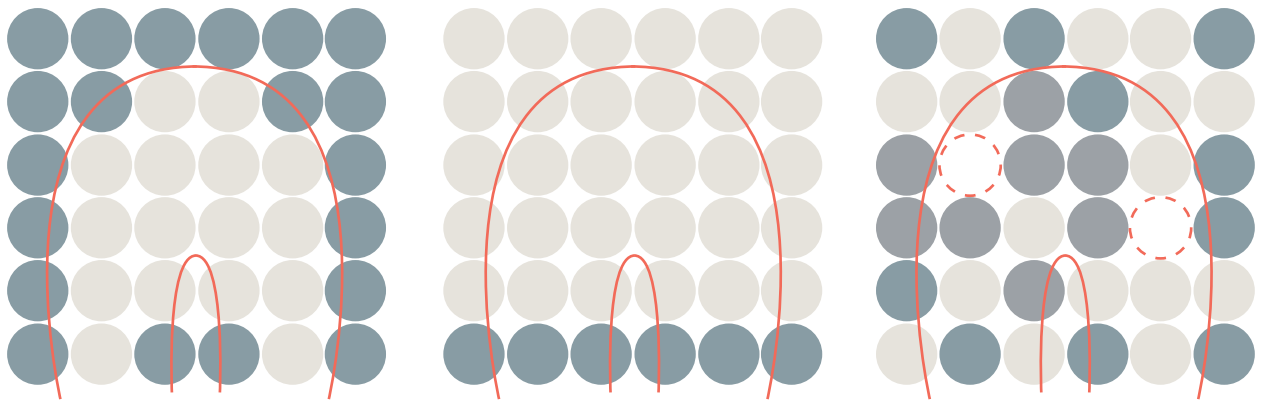

It is easy to adjust the shape and height. Where someone makes empty space depends on the location of the wound on the hip.

● Size

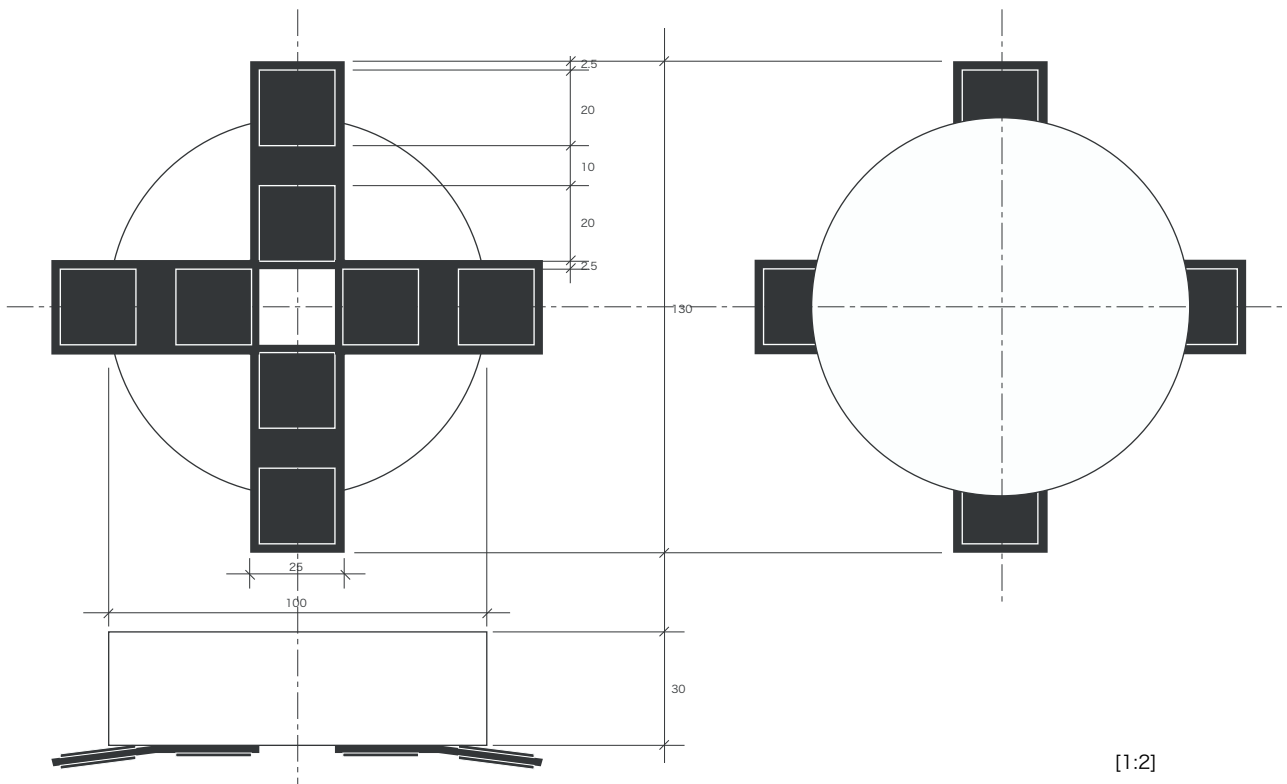

<3cm thick cushion>

DEVELOPMENT

POSSIBILITY AS A PRODUCT

The main goal for this project is to improve the quality of life for wheelchair users, and three types of cushions were proposed to prevent pressure sores. This project has the possibility to become a series of products for people who need this type of functionality. If that is so, then it can be expected that there is a broader target group which includes the elderly, other disabled people, infants and young children.

● Product distribution

Users can go to a shop which sells supportive devices and purchase the products. Many disabled people have own adviser (helper, physical therapist etc.) for their supportive device, thus if the adviser was requested to prepare the device for the user, they can contact to the shop.

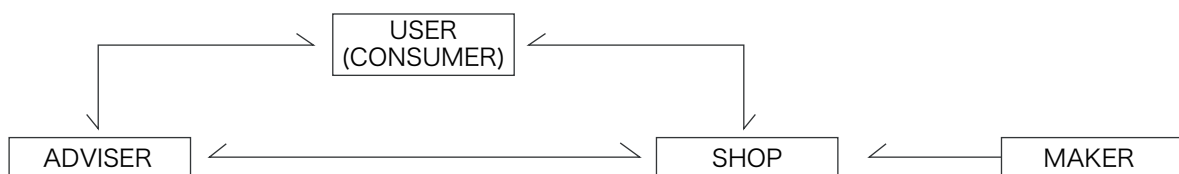

● Branding

To improve the value of the product, branding is one of the most useful tactics.

Generally, the image of nursing care products is medical, practical, and in this project, I propose to create a more fashionable image so that users(consumers) feel proud of owning it.

Product expansion possibilities: additional cushions, chairs, beds, bedclothes, etc.

● Brand name, image and logo

SEDE : “sede” means “seat” in Latin. More products will be developed but the brand starts with three cushions for seats. The name comes from the initial intent and scope for the products.

Moodboard for SEDE product is on page 24.

The logos of the brands of wheelchair and other products in this field tend to have a sporty image. SEDE features luxury and specialness thus the logo should express these images.

Brand logo

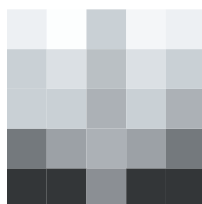

S E D E

The logo can be separated depend on the usage and the situation. The graphic image above comes from BREATHAIR blocks.

REFLECTIONS

Medical technology is constantly advancing. Not long ago in Japan, it seemed that the bed sore which is caused by long-term static spine positions due to illness should be dried as a form of treatment. More than anything else, treatment for the initial illness had tended to be given a higher priority and treatment for the related wounds tended to be prioritized lowly. But now non-operative treatment typically consists of moisture healing, that is, to deal the wound by keeping moisture in the affected area. How to deal with the disease and injury changes with the advancement or discovery of additional treatments. Products such as assistive devices for physical disabled people are closely related to that field and the designer always must be sensitive to the trends to cope with change.

The cushions which I proposed in this project focus on the prevention of pressure sores. For prevention of the pressure sore, it is said that keeping the skin clean is of the same importance as frequent postural change and fine nutritional care.

The largest features of the main product; a cushion for wheelchairs, are excellent progress in breathability, lightness, customization and ease of washing. For the people who already have a sore, the merit is the washability and adjustability of the inner blocks depending on the sore's location.

The new material BREATHAIR is indispensable in the realization of the above mentioned traits. Designers should avoid relying on material too much, but in this case this should be viewed as development of the product as a response to medical advancement.

I had been thinking that it is important to sell this kind of product relatively inexpensively in order to encourage many people to buy it, but in the examination of this project, my opponent pointed out the possibility to shape the product's brand to make people feel proud to own it. It was an understandable opinion and could succeed in the country like Sweden, but would be difficult in a country like Japan which has quite heavy competition. As the target of the product is wide, the possibility for sales should be high. This is an issue when considering the actual sale of the product.



SOURCES / LIFERENCES

< page6 >

- 1 <http://www.therohogroup.com/popup.jsp?Title=MID%20PROFILE%20QUADTRO%20SELECT%20CUSHION&Image=d2-quadtro>
- 2 http://www.francebed-ms.com/item/item_00163.html
- 3 <http://www.vicair.com/oudesite/index.htm>
- 4 http://www.invacare.com/cgi-bin/imhqprd/inv_catalog/prod_cat_detail.jsp?prodID=EC
- 5 <http://www.jsleep.com/care/caringcushion.html>
- 6 <http://www.spinalistips.se/tips-stimulite-en-979.html>

< page9 >

- 1 <http://www.mogulax.jp/html/newpage.html?code=6>
- 2 <http://www.mogus.jp/beads/>

Mitsuno, Yuji (2009), "Advancing wheelchair Panthera" Haru Shobo, ISBN 978-4-89984-107-4

Mitsuno, Yuji & Yoshikawa, Kazunori (2007), "Introductory guide of seating -From the estimation of seated posture to wheelchair adjustment - " Chuohoki Publishing , ISBN 978-4-8058-2878-6

Gender : Male / Female

Age :

History of wheelchair usage (How many years) :

Type of physical disability :

Occupation :

Hobby :

1. Type of currently-used cushion
2. How long have you been using the cushion?
3. Have you used other type of cushion? Yes / No
If Yes, what type of cushion is it? Why did you change the type?
4. Are you satisfied with the cushion you are using now? Yes / No
If Yes, why? Mention the good points of the cushion.
If No, why? Mention the bad points of the cushion.
5. Have you suffered any pressure sore? Yes / No
If Yes, how long ago was it?
How many times?
How long did it take to recover?
How was your feeling in that time?
6. What is the most important characteristic for wheelchair cushions?
7. Do you want better looking cushion? Yes / No
8. What color of cushion do you want?
9. How often do you wash the cushion?
10. Do you sit down on ordinary sofas and chairs at home? Yes / No
If Yes, is it custom-made for you? Yes / No
Do you sit down using a cushion? Yes / No
What kind of cushion is it?
11. Do you drive car? Yes / No
If Yes, do you use cushion on the car seat? Yes / No
12. Do you sit down in an ordinary seat on the train and airplane? Yes / No
If Yes, what kind of cushion is it?
13. How long do you sit down in a wheelchair everyday?
14. If you could get new type of cushion, what kind of cushion do you want?
15. If you can mention something else about wheelchair cushions, please tell me.

The pressure test of the cushion for wheelchair will be held after the deadline of this report.
The result will be added if it is possible to attach it afterward.

