

Tanya De L. Karlson

Regulation of mucosal inflammation by fibroblasts



GÖTEBORGS UNIVERSITET
Department of Microbiology and Immunology
Sweden 2007

Regulation of mucosal inflammation by fibroblasts

Tanya De L. Karlson



GÖTEBORGS UNIVERSITET

Department of Microbiology and Immunology
Sweden 2007

*I would like to dedicate this thesis
to two very special persons in my
life;*

*To my mother from whom I get my
strength and who taught me never
to give up
and*

*To the little person that puts such
light into my life and made me
forget the difficult times, my
beautiful godson/nephew Alexander*

ABSTRACT

Acute inflammation in the bowel, a response of the immune system to infections or trauma, is probably a frequent but localized event, but when the barrier is repaired and the infection cleared, it is quickly followed by wound healing and resolution. However, in some individuals these mechanisms are not effective and the inflammatory bowel diseases, Crohn's disease and ulcerative colitis result. Common and important characteristics in both of these diseases are the increased accumulation of immune cells, especially non-apoptotic CD4⁺ T cells and the activation of non-immune cells, including fibroblasts, which then become directly involved in immune responses.

The aim of this thesis was to improve our understanding of the role of the mucosal fibroblasts in intestinal inflammation by analysing the molecular signalling mechanisms underlying their inflammatory potential. Fibroblast cell lines isolated from murine normal colon tissue and from the CD4⁺CD45RB^{high} –transplanted SCID mouse model of colitis were used.

Fibroblasts are known to express the membrane receptor CD40 which, through interaction with its ligand (CD40L), plays a key role in inflammatory responses. We showed for the first time the existence of a subpopulation of fibroblasts isolated from inflamed tissue which, despite having lower expression of membrane CD40 compared to normal fibroblasts, were able to respond vigorously to CD40 ligation, a response that was increased by IFN- γ . This indicated that the activated fibroblasts in colitis acquire a permanently activated phenotype.

Molecular studies performed to reveal the mechanisms underlying the synergy between CD40 and IFN- γ in inflamed cells, revealed co-operation between the transcription factors CAAT/Enhancer binding protein beta (C/EBP β) and Nuclear Factor kappa B (NF κ B). Both transcription factors were expressed constitutively at higher intensity in inflamed fibroblasts, compared to normal cells, rendering inflamed mucosal fibroblasts more sensitive to CD40 ligation and IFN- γ stimulation.

Co-cultures of normal and inflamed fibroblasts with CD4⁺ T cells showed that both fibroblast lines were equally efficient in promoting survival of CD4⁺ T cells, thus indicating the importance of the mesenchyme in immune homeostasis in the gut.

Finally, analysis of TGF- β ligation on the fibroblast lines showed that the increased and disrupted collagen deposition which had been observed in inflamed tissue could not be explained by simple dysregulation of signalling from the TGF- β R on inflamed fibroblasts.

In conclusion, the results of this thesis suggest that mucosal fibroblasts in chronic inflammation respond to the surrounding milieu, become activated and transdifferentiate into a stable proinflammatory phenotype which may contribute to chronicity of the inflammation, and certainly influences its pathogenesis.

Key word: inflammatory bowel diseases, fibroblasts, CD40, C/EBP β , apoptosis, TGF- β

ISBN 978-91-628-7170-3

ORIGINAL PAPERS

This thesis is based on the following papers, which are referred to in the text by their Roman numerals (I-IV)

- I Tanya De L. Karlson, Christine V. Whiting and Paul W. Bland. (2007)**
Proinflammatory cytokine synthesis by mucosal fibroblasts from mouse colitis is enhanced by interferon- γ -mediated up-regulation of CD40 signalling. *Clinical & Experimental Immunology* 147 (2), 313–323

- II Tanya De L. Karlson, Maria Ormestad and Paul W. Bland**
Activated fibroblasts from mouse colitis upregulate the transcription factor, C/EBP β , which transactivates CD40-mediated proinflammatory signaling through NF κ B. *Manuscript*

- III Tanya De L. Karlson and Paul W. Bland.**
Fibroblasts from normal and inflamed murine colon are equally efficient inhibitors of CD4⁺ T cell apoptosis. *Manuscript*

- IV Christine V. Whiting, Tanya De L. Karlson, John F. Tarlton, Ian Paterson and Paul W. Bland.** Regulation of TGF- β -mediated collagen production by mesenchymal fibroblasts from murine colitis. *Manuscript*

CONTENTS

ABBREVIATIONS	6
INTRODUCTION	7
Inflammatory bowel disease.....	7
Fibroblasts.....	10
The role of fibroblasts in inflammation.....	13
AIMS OF STUDY	29
GENERAL MATERIALS AND METHODS	30
Cell lines and stimulations	30
Flow cytometry analysis.....	31
Immunohistochemistry	31
Luminex.....	33
SDS-PAGE Western blot.....	33
Isolation of CD4 ⁺ T cells.....	35
Fibroblasts and T cells co-cultures.....	35
T cell proliferation assay.....	36
Luciferase reporter assay.....	36
Real-time PCR	37
RESULTS AND COMMENTS	39
CD40 expression on fibroblasts and cytokine/chemokine production (paper I).....	39
Expression of C/EBP β (manuscript II).....	43
Rescue of CD4 ⁺ T cells from apoptosis by fibroblasts (manuscript III).....	48
TGF- β -mediated collagen production by fibroblasts (manuscript IV).....	50
GENERAL DISCUSSION	54
ACKNOLEGEMENTS	61
REFERENCES	64
PAPERS I-IV	

ABBREVIATIONS

bFGF	basic fibroblast growth factor	SCID	severe combined immunodeficient
CCL	chemokine (CC-motif) ligand		
CD	Crohn's disease	SCF	stem cell factor
Col	collagen	SDF	stromal cell derived
COX2	cyclo-oxygenase 2	SMA	smooth muscle actin
CXCR	Chemokine, CXC Motif, Receptor	SMAD	mothers against decapentaplegic homolog
CTGF	connective tissue growth factor		
dsRNA	double stranded RNA		
ECM	extracellular matrix	SMM	smooth muscle myosin
ERK	extracellular signal-regulated Kinases	STAT	signal transducer and activator of transcription
FGF	fibroblast growth factor		
GAS	gamma-activated sites		
GATE	gamma-activated transcriptional element	TGF- β	transforming growth factor beta
GM-CSF	granulocyte-macrophage colony-stimulating factor	TGF- β RII	transforming growth factor receptor II
gp	glycoprotein	Th	T helper
IBD	inflammatory bowel disease	Thy	thymocyte-differentiation antigen
ICAM	intercellular adhesion molecule		
IGFI	insulin growth factor I	TNF	tumor necrosis factor
IL	interleukin	TIMP	tissue inhibitor of metalloproteinase
IFN	interferon		
IP	inducible protein	TRAF	TNF receptor associated factor
ISGF	interferon stimulated gene factor		
JNK	c-Jun N-terminal Kinase	TYK	tyrosine-protein kinase
LPS	lipopolysaccharide		
MAP	mitogen-activating protein	UC	ulcerative colitis
MIP	monocyte inhibitory protein		
MMP	matrix metalloproteinase		
N-CAM	neural-cell adhesion molecule		
NF κ B	nuclear factor kappa B		
NIK	NF κ B Kinase		
NK	natural killer		
PDGF	platelet-derived growth factor		
PGE	prostaglandin E		
PGN	peptidoglycan		
RA	rheumatoid arthritis		
SARA	Smad anchor for receptor activation		

INTRODUCTION

General aim of the thesis

The inflammatory bowel diseases, Crohn's disease and ulcerative colitis, are chronic inflammatory disorders of the gastrointestinal tract. The exact pathogenetic mechanisms of the diseases are not known, but there is evidence that environmental, genetic and immunological factors contribute and prevalence of the diseases is increasing in the Western world (1). Although chronic gut inflammation is characterized by extensive infiltrates of immune cells, such as neutrophils, mast cells, eosinophils and CD4⁺ T cells, into affected tissues there is increasing evidence that non-immune cells – particularly mesenchymal cells (fibroblasts, myofibroblasts and muscle cells) – become involved in, and may regulate, the inflammatory process. In the case of fibroblasts, it has been shown that they function not only in the production of matrix components, but can actively synthesize, and respond to, inflammatory mediators, making them important players in the inflammatory milieu.

The aims of this thesis were to investigate the inflammatory potential of gut mucosal fibroblast populations and to characterize the molecular mechanisms underlying their role in colon inflammation.

Inflammatory bowel diseases

The inflammatory bowel diseases (IBD), ulcerative colitis (UC) and Crohn's disease (CD), have a prevalence in Sweden of 243/100000 for UC and 146/100000 for CD (2). UC causes inflammation and ulcers in the superficial mucosa of the large intestine and CD causes transmural inflammation in any part of the gastrointestinal tract from mouth to anus. The initiating factor of inflammation in IBD is unknown, but is assumed to be some environmental factor or factors associated with the normal commensal flora, together with genetic factors (3, 4). CD and UC are characterised by the accumulation and infiltration of a mix of cells in the affected areas and increased production of proinflammatory cytokines which will have an effect on other cells in the local mucosal environment, thus intensifying the inflammation (5, 6).

Chemokines

Recruitment of leukocytes to sites of inflammation depends on the production of chemotactic peptides called chemokines. In IBD, changes in the levels of chemokines such as interleukin (IL)-8, monocyte chemoattractant protein 1 (CCL2), monocyte inflammatory protein 1 α (CCL3), RANTES (CCL5) and inducible protein (IP)-10 (7-10) are increased, thus promoting a higher infiltration of inflammatory cells, such as eosinophils, neutrophils, plasma cells and lymphocytes to affected areas of the bowel wall (11-14).

Cytokines

Apart from the important function of chemokines in inflammation, the cytokine milieu in the tissue is essential to develop an adaptive immunity. Cytokines produced by a variety of lymphoid, myeloid and mesenchymal cells are involved in different biological processes, such as differentiation, activation and growth play a key role in inflammation (15).

With regard to effector T cell cytokines, there is some evidence that CD can be characterized as a Th₁-mediated disease and UC as Th₂-mediated. The cytokine profile of CD consists of increased production of IFN- γ and IL-12, which induces the differentiation of macrophages to produce the proinflammatory cytokines IL-1 β , IL-6, IL-8, granulocyte-macrophage colony-stimulating factor (GM-CSF) and tumor necrosis factor (TNF)- α , while the cytokine profile for UC involves IL-4, IL-5, IL-10 and IL-3 (16-18).

Co-stimulatory molecules

In addition to cytokines playing an important role in IBD, co-stimulatory molecules, such as CD40 have also been shown to play a role in the development of disease.

CD40 and CD40ligand (CD40L) interaction has been shown to influence the balance between Th₁ and Th₂, depending on the strength of the interactions between CD40/CD40L (19), but this is still controversial. Despite the correlation between Th₁/Th₂ and the interaction between CD40/CD40L it is clear that signaling through CD40

in the development of colitis is of importance as demonstrated by the use of anti-CD40 in a Rag-1^{-/-} or SCID mouse model. Stimulation with anti-CD40 resulted in wasting disease, inflammation of the colon and liver pathology (20.). The relevance of CD40/CD40L interactions and participation in immune responses was also demonstrated by Liu et al. (1999) (21). Thus, blocking the CD40/CD40L interactions between peripheral blood T cells and lamina propria cells taken from CD and UC patients significantly decreased IL-12 and TNF- α production by monocytes.

Expression of CD40 and CD40L has also been shown to be upregulated in CD and UC (21, 22), which correlates with the findings of upregulated activation of the transcription factor, Nuclear Factor Kappa B (NFkB), in a number of inflammatory disorders, including rheumatoid arthritis (RA) (23, 24) and IBD (25-27).

Apoptosis

One very important aspect of the control of any immune response is the regulation of lymphocyte populations. In the gut mucosa, T cells are constantly exposed to antigens crossing the luminal barrier and so, in order to avoid continual expansion of these reactive T cell clones, one important mechanism of control and prevention of inflammation is by activation-induced effector T cell death – apoptosis. This mechanism is, therefore, fundamental to the maintenance of immune homeostasis in the intestine (28, 29).

In both CD and UC, the lifespan of lamina propria T cells has been shown to be prolonged, resulting in an ongoing and chronic immunological response in the affected sites of the gut (30, 31). This prolongation of the survival of T cells at the site of inflammation has been previously shown to depend particularly on the Bcl-2 family of apoptosis-regulatory proteins. Among these proteins, Bcl-2 and Bcl-x_L function as inhibitors of apoptosis and, opposing this, the Bax protein promotes the process that leads to cell death by apoptosis. In CD, lamina propria T lymphocytes have been shown to have a low expression of Bax while the Bcl-x_L/Bax ratio was elevated (32).

Persistent survival of T lymphocytes is but one possible reason for the maintenance of gut inflammation in IBD in a chronic state. The inflammation in these patients is usually well-controlled by a battery of effective immune-modulating drugs – aminosalicylates; corticosteroids; cytotoxics; and, increasingly, TNF- α -modulating antibody therapy. However, these diseases have a relapse-remission periodicity and will recur, suggesting that factors within the healed bowel are primed to re-activate the chronic inflammation, given the correct signals.

Cancer

Chronic inflammation in the bowel has also been shown to increase the risk of colorectal cancer, particularly in UC (33, 34). The exact factors underlying this abnormality are not known, but some correlations have been found with overproduction of IL-6. This pleiotropic cytokine, which is a key mediator of immune responses, is also involved in cell growth, differentiation, survival (35) and colon cancer (36, 37). One of the principal transcription factors responsible for the regulation of IL-6 is CCAAT/Enhancer binding protein beta (C/EBP β). This transcription factor is known to be involved in the regulation of cell growth, and, differentiation of many types of cells (38, 39) and in tumorigenesis. Increased expression of C/EBP β has been shown to correlate with human colorectal cancer (40).

Fibroblasts

Fibroblasts are the major cellular constituent of loose connective tissue and are found in all tissues of the body. They are adherent cells with a flat and elongated shape. Fibroblasts are of either mesodermal origin that builds up inner skin layers, bones, heart, and blood vessels, or of ectodermal origin that builds up skin, hair, nails (41). The origin of intestinal, liver and lung fibroblasts has been suggested as mesenchymal stem cells from the bone marrow (42).

Phenotype

Transplantation studies in vivo and in vitro have shown that hematopoietic stem cells from the bone marrow can differentiate within mucosal tissues into

fibroblasts/myofibroblasts (42, 43). A proposed scheme of transdifferentiation of bone marrow stem cells into fibroblasts/myofibroblasts (44) Fig. 1, shows that factors essential in the differentiation of stem cells are stem cell factor (SCF) and platelet-derived growth factor (PDGF). A range of other factors that have also been shown to influence the phenotype of fibroblasts and closely related myofibroblasts are indicated in Fig.1. Perhaps the most widely reported factor influencing the transdifferentiation of fibroblasts to myofibroblasts is transforming growth factor (TGF)- β 1. Fibroblast growth factor (FGF) on the other hand has been shown to reverse the myofibroblast phenotype and to promote instead a fibroblast phenotype (45, 46). The inflammatory cytokine CCL2 has also been shown to influence the transdifferentiation of fibroblast into myofibroblasts (47).

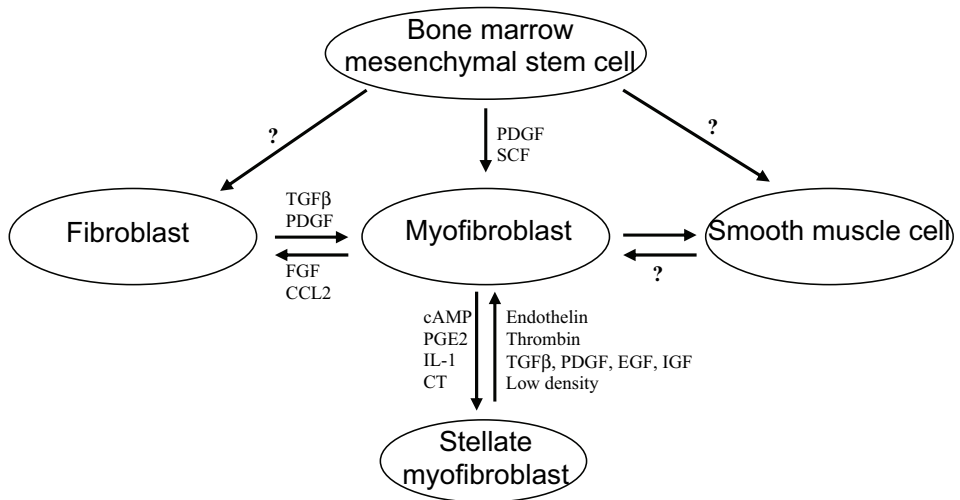

Figure 1. Hypothetical transdifferentiation scheme of bone marrow mesenchymal stem cells. Transdifferentiation of bone marrow into fibroblasts, myofibroblasts, smooth muscle cells and stellate cells is influenced by soluble factors such as, platelet-derived growth factor (PDGF); stem cell factor (SCF), transforming growth factor (TGF)- β , interleukin (IL)-1, fibroblast growth factor (FGF), epidermal growth factor (EGF), basic fibroblast growth factor (bFGF), insulin-like growth factor (IGF), connective tissue growth factor (CTGF) . Modified from Powell, D.W. *Am. J Physiol.* 1999.

The use of differential expression of structural proteins such as α -smooth muscle actin (α -SMA), smooth-muscle myosin (SMM), vimentin and desmin have been proven to be efficient markers in differentiating fibroblasts, myofibroblasts and smooth muscle cells from each other. In particular, α -SMA is a contractile protein found in the cytoplasm of smooth muscle cells and myofibroblasts, but not fibroblasts. The lack of smooth muscle markers such as SMM and desmin differentiates myofibroblasts from smooth muscle cells (48).

Function

The main function of fibroblasts is to produce extracellular matrix (ECM) components, which consist of glycosaminoglycans, proteoglycans and fibrous structural proteins such as laminin, fibronectin, elastin, desmin, vimentin and collagens that make up the extracellular matrix and maintain tissue architecture. The matrix proteins are also involved in wound healing and epithelial repair (49).

Heterogeneity of fibroblasts

Fibroblasts do not consist of a homogenous population of cells; they can differ between organs, between tissues and even within tissues. For instance, in human normal mucosa of the large intestine lamina propria stromal cells consist of at least two subtypes. One identified subtype is a pericryptal group that is α -SMA⁺, SMM⁺, vimentin⁺, and desmin⁻ which characterise myofibroblasts. The other identified subtype is nonpericryptal and is α -SMA⁻, SMM⁻, vimentin⁺ and desmin⁻, identified as fibroblasts (48). In regard to inflamed tissue, Whiting et al (2003) (50) found two main subtypes of mesenchymal cells in the mouse colon. One subtype consisted of α -SMA⁺ TGF- β receptor II⁺ which secrete basement membrane collagen IV and become activated in inflammation; and α -SMA⁻ TGF- β receptor II⁺, which secrete collagen I and are prominent pericryptally in normal tissue, and which accumulate at sites of epithelial ulceration in inflammation.

Heterogeneity among fibroblast populations has also been shown by differences in, for example, cytokine production, extracellular matrix components, proliferation rates (51-53) response to cytokines (54, 55) and expression of adhesion molecules (56).

One surface marker used by investigators to differentiate between fibroblast subpopulations is the surface glycoposphatidylinositol-linked protein CD90 (Thy 1.2). The function of Thy-1 is still unknown, but it has been shown to play a role in heterophilic cell adhesion, mediating Ca^{2+} -dependent cell contact between mouse thymocytes and thymic epithelial cells and cell growth and differentiation (57). Also, in experiments using rat lung fibroblasts, Thy1 was demonstrated to regulate focal adhesions, cytoskeletal organization and migration (58-60). Thy1^+ and Thy1^- populations of fibroblasts have also been demonstrated to differ in their production of, and respond to, cytokines and growth factors (61-63).

Fibroblast plasticity

Fibroblasts are multipotent cells - they can differentiate into other cells of mesodermal origin, such as cells that build up cartilage, adipocytes and muscle cells (41). The plasticity and ability of fibroblasts to transdifferentiate into other cell types has also been shown (64). Thus, fibroblasts can, for example, transform into endothelial cells during angiogenesis. Other proof of fibroblast plasticity was shown by Håkelién and her colleagues who demonstrated that fibroblasts can be reprogrammed to express T cell function by exposing permeabilized fibroblasts to extracts of T cells (65).

The role of fibroblasts in inflammation

Integrity and homeostasis of the gut barrier is essential in order to keep an appropriate immunological balance in the intestine. The principal component of the intestinal barrier - the epithelium - has multiple functions, including protection against mechanical damage or invasion by foreign organisms. However, the barrier function of the epithelium is not absolute and some antigens cross the epithelium and stimulate an immune response. Under normal conditions, these responses will be sufficient to clear the infection through the actions of infiltrating cells. Fibroblasts were, for a long time, considered to be responsible only for the production of extracellular matrix components. This assumption has been changed with the emergence of evidence showing that fibroblasts can also participate in immunological responses in direct response to proinflammatory signals in

areas such as: the regulation of normal barrier function of the epithelium (66); remodelling of infected tissue (67, 68); and regulation of the behaviour of infiltrating leukocytes to sites of inflammation (69, 70).

Production of cytokines/chemokines by fibroblasts

Fibroblasts can respond directly to components of the bacterial flora such as lipopolysaccharide (LPS). For example, LPS stimulation of human lamina propria fibroblasts induces expression of proinflammatory cytokines such as IL-1 α , IL-1 β , IL-6, IL-8, TNF- α , in addition to increased expression of intercellular adhesion molecules (ICAM)-1, Neural-cell adhesion molecule (N-CAM), adipocyte adhesion molecule (A-CAM) (71). In addition to actively participating as proinflammatory cells, fibroblasts can also respond to proinflammatory signals. Thus, fibroblast from various tissues have been shown to respond to proinflammatory cytokines such as IL-1 β (72, 73), TGF- β and TNF- α (74, 75).

Fibroblasts have also been shown to be among the many non-immune cells that readily generate chemokines and express chemokine receptors following cytokine activation, making them potential direct participants of an inflammatory reaction. An essential function of these chemokines is the recruitment of leukocytes to places of inflammation. Fibroblasts from a variety of human tissues, such as lung, spleen, kidney and breast have been shown to produce chemokines such as IL-8 (76), CCL2 (77), CCL3 (78), CCL5 (69), stromal cell derived factor (SDF)-1 and eotaxin (79). It has been shown by Brouty-Boye et al. (2000) that many cultured fibroblasts taken from different tissues were able to produce chemokines and that this production reflected the tissue of origin. They also noticed that the pathologic state of the tissue from which fibroblasts were isolated could influence their secretion of chemokines (79).

It has also been demonstrated that microbial ligands for toll-like receptors, such as double stranded (ds)RNA, LPS and peptidoglycan (PGN), together with IFN- γ induce the production of IP-10/CXL10 in human fibroblasts. This is an INF- γ -inducible protein that allows fibroblasts to attract CXC chemokine receptor 3 (CXCR3) expressing activated T

cells and natural killer cells (80). Table 1 shows a summary of some of the proteins produced and expressed by fibroblasts.

Table 1. Cytokines, chemokines, growth factors and receptors expressed by fibroblasts.

Cytokines	Chemokines	Growth factors	Receptors
IL-1 (75)	CCL2 (81)	PDGF (82)	CD40 (79)
IL-6 (83)	CCL3 (79)	SCF-1 (84)	TGF- β RI/II (50)
IL-8 (83, 85)	CCL5 (72, 79)	TGF- β (86)	IL-4R (87)
IL-10(75)	IP-10 (88)	KGF (89)	IL-6R (90)
		bFGF-2(91)	IL-8R (92)
		TGF- β (86)	IGF-IR (93)
			CCR2 (94)

Fibroblasts and T cell apoptosis

Through the action of programmed cell death/apoptosis, activated T cells can be cleared from sites of infections in order to maintain tissue homeostasis. Fibroblasts have been implicated in the chronicity of inflammation by prolonging survival of activated T-cells, resulting in persistence and accumulation of these cells in the affected areas, as in RA (95). Fibroblast-derived factors have been shown to promote T-cell survival by promoting the selective induction of anti-apoptotic genes, bcl-2 and bcl-x_L, thus allowing T cells to continue functioning at the site of inflammation, resulting in a prolonged abnormal immunological response with the potential for maintaining chronicity (96, 97).

Activated phenotype

Fibroblasts are extremely interesting cells when it comes to their ability to acquire an activated phenotype and maintain this phenotype for a long period of time. Examples of this property of fibroblasts have been shown by the study of synovial fibroblasts in vivo experiments. These experiments consisted of implanting RA synovial tissue into SCID mice to study the fate of inflammatory cells. Lymphocyte infiltrates disappeared with time, but RA synovial fibroblasts survived and maintained their activated phenotype in the tissue (98). The exact mechanisms supporting this activated phenotype are not

known, but investigations done in SCID mouse models have pointed out the importance of signaling pathway involvement in the acquisition of the activated phenotype. For example, Takayanagi et al. (1999) demonstrated that inhibition of Src family tyrosine kinases inhibited the proliferation of RA synovial fibroblast and the production of IL-6, which is known to be also upregulated in IBD (99, 100).

NFkB is another example of factors shown to be involved in the activated phenotype of synovial fibroblasts and other cells in inflammatory diseases (101). The group of Makarow et al. (1997) showed that disruption of the activation of NFkB inhibited inflammatory responses (102). Another factor involved in the extensive life of the fibroblast has been shown to involve the expression of the tumour repressor gene p53 in synovial fibroblasts. Mutations in RA patients which suppress p53 function were shown to reduce the proliferation and invasiveness of synovial fibroblasts in these patients (103).

Fibroblasts and chronicity

Already in 1997, Smith et al. (104) suggested the idea of considering fibroblasts as sentinel cells, based on the observations that fibroblasts function not only as structural elements, but also have immuno- regulatory function. This suggestion has been strengthened by accumulating data, suggesting that fibroblasts are responsible for the chronicity of diseases such as IBD and RA, in addition to their direct involvement in immune responses.

Fibroblast involvement in immune responses through the production of cytokines, chemokines, recruitment of cells to sites of inflammation, longevity and heightened activation in inflamed tissue, has made fibroblasts candidates for maintaining the chronicity of inflammatory diseases.

As suggested by Buckley et al. (2001) (105), transition to chronic inflammation could start with the activation of resident cells, such as macrophages and fibroblasts, in the tissue by danger signals. This innate immune response will start the synthesis of cytokines and chemokines, activating and attracting lymphocytes and myeloid cells to the

affected sites. Through the involvement of activated dendritic cells moving from the affected tissue to the draining lymph nodes and presentation of the antigen to T cells and B cells, an acquired immune response will begin. Once the pathogen has been removed, repair of tissue will begin and the inflammation will subside.

Buckley suggests that chronic inflammation relates to the inability of activated fibroblasts to switch off their production of chemokines, resulting in an accumulation of leukocytes in the inflamed tissue which maintains the activated state and disrupts tissue repair. The retention of leukocytes in the tissue is the result of the production of SDF-1 and IFN- β by fibroblasts (Fig.2).

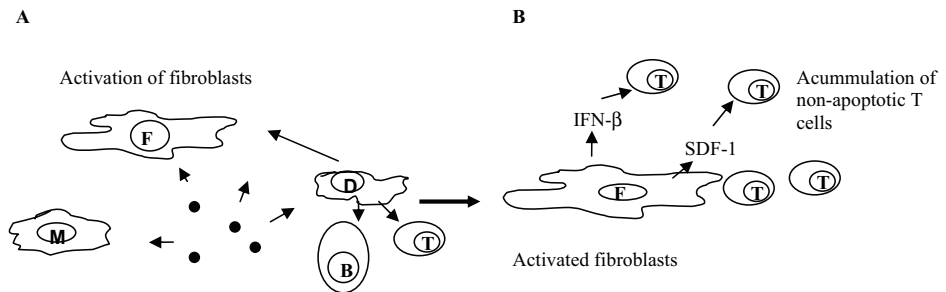

Figure 2. Proposed involvement of fibroblasts in chronic inflammation. (A) Activation of resident cells by danger signals, results in activation of cells such as macrophages (M) and dendritic (D) cells as well as fibroblasts (F). This activation results in an innate response with increased synthesis of cytokines/chemokines attracting lymphocytes and myeloid cells to affected areas. The interaction of activated dendritic cells with T and B cells will result in an acquired immune response, thus resolving the inflammation. Fibroblasts affected by various factors produced during inflammation will acquire a persistently activated phenotype. Inability of fibroblasts to switch off their production of chemokines will turn an acute inflammation into a chronic persistent inflammation. Modified from Buckley, D. *Trends in Immunology* Vol. 22, no. 4, 2001.

Factors involved in the activation of tissue fibroblasts include alterations in several signal pathways, including NF κ B. Thus, it has been shown that regulation of the switch from

acute to chronic inflammation in fibroblasts depends on the expression of RelB (106). Further, the importance of RelB in immunological functions has been clearly demonstrated, as RelB-deficient mice die from overwhelming inflammation (107).

Another factor demonstrating possible fibroblast involvement in the chronicity of IBD is the irreversible accumulation of collagen. Lawrance et al. 2001 demonstrated the existence of an activated subpopulation of fibroblasts that compared to normal fibroblasts secreted increased amounts of collagen isolated from both CD and UC (67).

There is still much to be studied regarding the involvement of fibroblasts in the chronicity of disease, especially immuno-regulatory pathways, but the evidence so far indicates that fibroblasts are important components in the switch to chronic inflammation

Activation of fibroblasts

A very important factor involved in the synthesis of proinflammatory cytokines and chemokines is the costimulatory integral membrane protein, CD40 and its ligand, CD154 (CD40L) (108). Signaling from CD40 is an essential factor involved in the regulation of inflammation through the engagement of NF κ B. Fibroblasts from several tissues, including uterus, synovium, skin, muscle, gingiva, gut and lung (109-112),(79) have been shown to constitutively express CD40, and upregulation of this expression by IFN- γ stimulation has been demonstrated. Engagement of this CD40 results in increased synthesis of proinflammatory cytokines, such as IL-1, IL-6, IL-8 and other mediators, including cyclo-oxygenase (COX)-2 products, together with ECM proteins (113-116). This receptor allows fibroblasts to regulate the behaviour of cells that express the CD40L and which infiltrate to the site of damage (117). In IBD, expression of CD40 has been shown to be upregulated and the hyperexpression of CD40L in CD has been shown to contribute to the pathogenesis of the disease by increasing the production of cytokines (21, 22).

CD40 and its crucial involvement in immune regulation

The cell surface receptor molecule CD40 (50-kDa) was first identified in 1985 on B cells (118). The receptor is a type I transmembrane glycoprotein, which belongs to the tumour necrosis factor receptor (TNF-R) family. Stimulation of B cells through CD40 by its ligand on activated T-cells induces B-cell proliferation, immunoglobulin (Ig) production, isotype switching, regulation of cell death and germinal center formation (119, 120). Since its identification, CD40 has also been reported not only on mature B cells but in immature B cells, epithelial cells, endothelial cells, monocytes, dendritic cells and fibroblasts (113, 120, 121). CD40 is engaged by ligation of CD40L (CD154), a member of the TNF family, which is expressed predominantly on mature, activated CD4⁺ T cells, mast cells, basophils and eosinophils (122-124). Interactions between CD40 and CD40L result in diverse immunological changes, for example, alteration of processing and presentation of antigens by antigen presenting cells (APC); cytokine and chemokine production; proliferation; and up-regulation of cell surface proteins (125, 126).

In the works of Fries, Sempowski and others, it has been shown that under normal conditions fibroblasts display a constitutive, but low, level of CD40 which can be upregulated through the effects of INF- γ (113, 114). Activation of fibroblasts through CD40 is dependent on the binding of CD40L expressed by T-cells, mast cells, basophils and eosinophils (122, 127, 128).

The exact role of CD40 in fibroblasts is still not known, but one important aspect of the engagement of CD40 is the mobilisation of members of the NF κ B/Rel family, which results in the production of proinflammatory cytokines and immune responses (129-131). In vertebrates, the Rel family consist of NF κ B1 (p50), NF κ B2 (p52), c-Rel, RelA (p65) and RelB (132).

CD40 has no intrinsic enzymatic properties, so it associates with the TNF receptor associated factor (TRAF) family. The signaling cascade through the involvement of different TRAF members activates various protein tyrosine kinases such as c-Jun N-terminal kinase (JNK), mitogen-activated protein kinase (MAPK) p38, extracellular

signal-regulated kinase (ERK)1/2 and the activation of NFκB kinase NIK, responsible for the dimerization of IκK, formed by Iκ kinase-α and Iκ kinase-β (IκKα/IκKβ). The IκB protein, which functions as an inhibitor to NFκB by retaining it in the cytosol, is then phosphorylated by IκK, causing it to be ubiquitinated, hydrolyzed by the proteasome and dissociated from NFκB, allowing the transcription factor to translocate into the nucleus (Fig. 3). NFκB is a major regulator of proinflammatory cytokines, such as IL-1, IL-6, IL-10, IL-12 and TNF-α. In response to CD40 ligation (117), fibroblasts upregulated ICAM-1, COX2 expression and prostaglandin (PG)E₂ synthesis (115, 133, 134). Previous work has shown the importance of the different components of NFκB in immunological responses. LPS-stimulated *RelB*^{-/-} fibroblast showed a persistent induction of chemokines such as CCL3, CCL4, IP-10, and CCL5. This overexpression of cytokines correlated with the overexpression of NFκB, p50, p65 and IκB α (107). *RelA*^{-/-} mouse fibroblasts stimulated with TNF-α showed a reduction in viability (135).

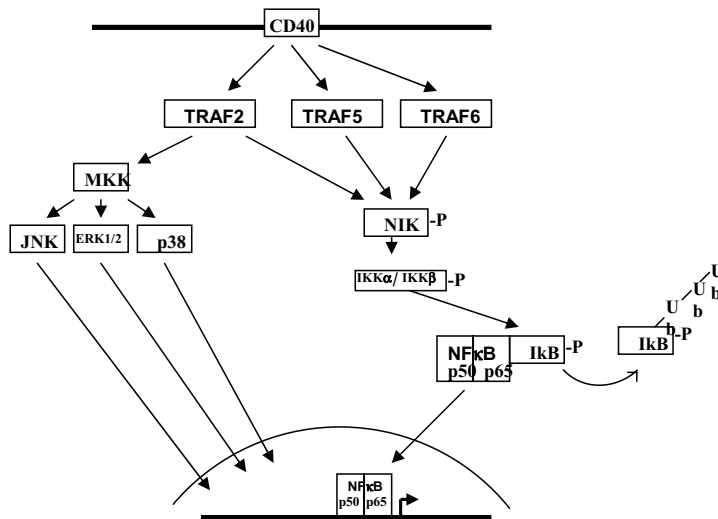

Figure 3. CD40 signaling pathway

As stated above, upregulation of CD40 expression on cells can be achieved by IFN- γ stimulation. This soluble cytokine is produced by natural killer (NK) cells as an early inflammatory response and in larger amounts by effector T cells during the subsequent acquired immune response. The intracytoplasmic signaling response to IFN- γ starts with the binding of IFN- γ to the interferon gamma receptor, which is composed of two polypeptides, a constitutively produced high affinity binding alpha chain, the interferon gamma receptor 1 chain (IFN- γ R α), and an inducible beta chain, interferon gamma receptor 2 chain (IFN- γ R β), which is responsible for signal transduction. IFN- γ binding causes the dimerization of both chains which leads to autophosphorylation of the Janus kinases, Jak1 and Jak2. This phosphorylation event, in turn, results in the phosphorylation of signal transducers and activator of transcription protein (STAT)-1 forming the STAT-1 homodimeric transcription factor, STAT1, which translocates to the nucleus and binds specific DNA sequences known as gamma-activated sites (GAS) (136).

Other transcription factors upregulated by IFN gamma

In 1997 the group of Kalvakolanu (137) identified a novel IFN- γ response element denominated gamma-activated transcriptional element (GATE) a transcriptional element that differs from GAS. One transacting factor shown to interact with GATE in an IFN- γ dependent way is the CCAAT/Enhancer binding protein beta (C/EBP β) (138). This transcription factor is one of six members of the C/EBP transcription factor family, denominated C/EBP- α - ξ . Table 2 shows the alternative nomenclature of C/EBP genes, source and tissue expression. They belong to the family of basic leucine zipper transcription factors and although they are structurally similar, they are genetically and functionally different. This family of transcription factors is involved in a number of processes from cellular differentiation, proliferation to control of metabolism and inflammation (39). The C/EBP β member, also known as NF-IL-6 due to its involvement of IL-6 regulation, has been shown to participate in the regulation of immune and inflammatory responses in cells such as B cells, monocytes, macrophages, epithelial cells and fibroblasts (38, 39).

Table 2. The C/EBP family. Modified from Ramji, D.P. *Biochem. J.* 365 (2002) and Lekstrom-Himes *The journal of biological chemistry*, 273 (1998)

Name	Alternative name	Expression	Source
C/EBP α	C/EBP	Liver, adipose tissue, Intestine, lung, Adrenal gland, Placenta, ovary Peipheral blood Monoclonal cells	Rat, mouse, human, chicken, bovine, <i>Xenopus laevis</i> , <i>Rana catesbeiana</i> , fish
C/EBP β	NF-IL-6, IL-6DBP LAP, CRP2, AGP/EBP, NF-M ApC/EBP	Liver, intestine, lung, adipose tissue	Rat, mouse, human, chicken, bovine, <i>Xenopus laevis</i> , <i>Aplysia</i> , fish
C/EBP γ	Ig/EBP-1	Ubiquitous	Rat, mouse human, chicken, fish
C/EBP δ	CELF, CRP3, NF-IL-6b RcC/EBP2	Liver, lung, adipose tissue, intestine	Rat, mouse, human <i>Rana Catesbeiana</i> , bovine, ovine, fish
C/EBP ϵ	CRP1	Myeloid and Lymphoid lineages	Rat, mouse, human, ovine, fish
C/EBP ζ	CHOP, Gadd153	Ubiquitous	Rat, mouse, human, hamster

Phosphorylation of C/EBP β has been suggested to play a key role in the transcriptional activation of this transcription factor. Phosphorylation of an inhibitory domain that contains several serines and threonines on C/EBP β allows the transcription factor to enter the nucleus where it can start transcription of target genes (39, 139). Because C/EBP β has the ability to form homodimers and heterodimers, which allows it to build complexes with other transcription factors (Fig. 4), a mechanism exists for trans-activational synergy, as in the case of NF κ B, in which they are able to regulate and control the transcription of adjacent or distant multiple genes (140-142).

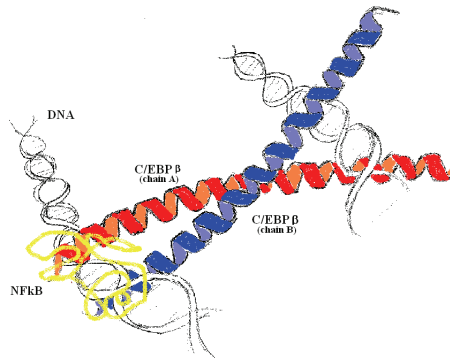

Figure 4. Representation of how the leucine-zipper segments of C/EBP β chain A and chain B bind to NF κ B (in yellow) and build a complex.

Interleukin 6

The proinflammatory cytokine, IL-6, was first cloned in 1986 (143). Since then, this pleiotropic cytokine has been shown to be involved in a range of biological activities, such as T and B cell differentiation and proliferation, stimulation of the acute-phase response and cancer development. It is synthesised by various cells, such T cells, B cells, monocytes, fibroblasts, endothelial cells and some tumour cells (35) (144, 145).

The effects of IL-6 are initiated by its interaction with either a membrane-anchored receptor or a soluble form of the IL-6 receptor, which transmit signaling through a process called trans-signalling. Once IL-6 binds to either the membrane-anchored or soluble receptor, trans-signalling will continue through a signal-transducing glycoprotein (gp) 130 (146). This event results in the activation of cytoplasmic tyrosine kinases (JAK1, JAK2 and TYK2), and phosphorylation and activation of STAT1 and STAT3 transcription factors which allows them by forming STAT3/STAT3 homodimers to enter the nucleus and initiate transcription of genes that contain STAT3 response elements. Interleukin-6 can also activate the Ras-Raf pathway, which activates MAP kinases, resulting in the activation of the transcription factors NF-IL-6 (C/EBP β) and AP-1, which can act through their own cognate response elements (147-149). C/EBP β , that is known

to build a complex with NF κ B/p65, has been shown to synergistically activate IL-6 transcription (150).

Over-expression of IL-6 has been shown to correlate with the pathogenesis of immunological diseases such as CD, RA and in neoplastic diseases, such as breast and colon cancer. In prostate cancer, in which increased amounts of IL-6 were found both in patients' serum and tissue, the interleukin was also shown to act as an autocrine growth factor (140, 151).

Based on the knowledge that IL-6 is over-expressed in inflammatory disease, attempts to find different strategies to block IL-6 signaling have been tested. Clinical trials, in which mAb against IL-6 were used to block IL-6 signaling, were shown to be unsatisfactory as the blocking resulted in an increased half-life of IL-6. In another attempt to block IL-6 signaling, a humanized anti-IL-6 receptor antibody was developed. This time the blocking of the receptor showed satisfactory results without increasing the half-life of IL-6. Use of blockade of IL-6 receptor demonstrated a satisfactory result in clinical trials of Castleman's disease, adult and juvenile RA and CD (152), again demonstrating the crucial role of this pleiotropic cytokine in maintaining and amplifying inflammation.

Collagen and TGF- β

The collagen that is deposited in the intestine is mainly produced by fibroblasts/myofibroblasts and smooth muscle cells. Collagen is an important component of wound healing and repair of tissue damage. Many of the components produced by stationary and infiltrating cells in an inflammatory response affect the activities of fibroblasts. Some of the components produced during an inflammation have been shown to have opposing effects on fibroblasts, as in the case of TGF- β and IFN- γ (153). While TGF- β stimulates the secretion of collagen by fibroblasts, IFN- γ inhibits it (154, 155).

TGF- β has multifunctional roles. It is involved in the control of proliferation, differentiation, apoptosis and other functions in most cell types. It can also act as a negative autocrine growth factor (156). The mechanism whereby TGF- β stimulates cells

is through the engagement of the two main receptors, TGF- β receptor type II (TGF- β RII) and TGF- β receptor type I (TGF- β RI). Four other receptors are known; Betaglycan (formerly III) (157) and Endoglin (CD105) (158) that increase the affinity of TGF- β to TGF- β RII but are not signaling receptors, RIV has unknown function and RV (159), which can signal with TGF- β RI, or even in the absence of TGF- β RI and TGF- β RII.

Signaling starts with binding of TGF- β to TGF- β RII that is constitutively activated. This ligation causes TGF- β RII to bind to TGF- β RI, which becomes phosphorylated. TGF- β RI, now in activated state, will then signal into the nucleus through the phosphorylation of the receptor-regulated Smad2 and Smad 3 (other receptor regulated Smads 1, 5 and 8 mediate Bone morphogenetic proteins type I receptors signaling). Contact between TGF- β RI and Smad2/3 proteins involves the help of the Smad anchor for receptor activation (SARA). Once the Smads have been phosphorylated, they will form a complex with Smad4 allowing them to enter the nucleus and start gene expression through the engagement of, for example, co-activators and other transcriptions factors. The Smad proteins 6 and 7 have an opposite effect. Their function is to inhibit signaling into the nucleus. They perform this through an autocrine feedback loop. TGF- β stimulation increases the synthesis of the inhibitory Smad proteins and this causes feedback inhibition by inactivating the phosphorylation of the receptor-regulated Smads (160, 161) (Fig 5).

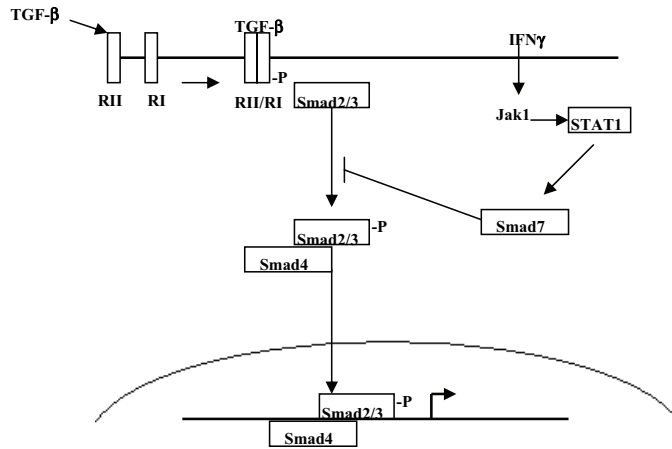

Figure 5. TGF- β and IFN- γ opposing effects. Modified from *Fiocchi, C. J. Clin. Invest. 108:523-526 (2001)*

As stated above, IFN- γ has an opposing role to TGF- β . IFN- γ signaling causes STAT1 to become phosphorylated and form a dimer allowing it to enter the nucleus and start the transcription and translation of inhibitory Smad 7. Increased levels of Smad 7 result in the inhibition of downstream signaling of TGF- β , e.g. phosphorylation of Smad 2/3 (162).

Ghosh et al. (2006) (163) propose an alternative mechanism whereby IFN- γ may affect the production of collagens by fibroblasts. In this case, IFN- γ functions through the engagement of the interferon stimulated gene factor (ISGF)3 γ , also known as p48, which signals through the involvement of the MAP kinases MEK1 and ERK1/2. Phosphorylation of these kinases results in the downstream phosphorylation of C/EBP β . Hue et al. (2001) (164), demonstrated that an AACTT sequence in the human pro-collagen Col1A2 promoter was identical to the GATE that is known to interact with C/EBP β .

Fibrosis

Fibrosis is defined as the formation or development of excess fibrous connective tissue in an organ or tissue as a reparative or reactive process. Under normal conditions, clearance of inflammation results in tissue damage due to the increased cellular infiltration into the lesion and to the contribution of these cells to reactive oxygen radicals and tissue degrading enzymes (165). Normally, efficient wound healing mechanisms would resolve the damage by the normal production of ECM. In IBD, the healing response is impaired, resulting in accumulation of ECM components (67, 166). Fibroblasts, myofibroblasts and smooth-muscle cells, as the major producers of ECM proteins, are regarded as the main cells responsible for intestinal fibrosis.

Collagens type I, III, IV and V mRNA and proteins have been shown to be increased in patients with IBD (167). What causes accumulation of ECM and the exact mechanisms behind this impairment are not known, but the balance between degradation of ECM by matrix metalloproteinases (MMPs) and ongoing collagen synthesis by mesenchymal cells has been proposed as a factor influencing the development of fibrosis.

TGF- β is a multifunctional protein that controls cell proliferation, differentiation, wound healing and fibrosis (168). It is increased in fibrotic diseases and fibrotic areas of tissue. Animal models have demonstrated that exogenous administration of TGF- β caused fibrosis in organs and that treatment with anti-TGF- β reduced fibrosis (169). Also, TGF- β upregulates the expression of tissue inhibitors of metalloproteinases (TIMPs), which regulate the activity of MMPs, disrupting the balance between these two factors.

The use of mouse models of inflammation

Mouse models have been useful tools in the understanding of the pathology of human IBD. They can be grouped into; those induced by chemical agents; adoptive transfer models; transgenic and knockout models; and spontaneous models (170). To some extent they can be sub-divided in terms of Th₁ and Th₂ effector T cell function. Table 3 summarises the most commonly used mouse models.

The fibroblast cell lines used throughout this work were isolated from the CD45RB^{high} SCID adoptive transfer mouse model.

In 1993 Morrissey et al. (171) and Powrie et al. (1993) (172), showed that transfer of whole populations and fractionated population of CD4⁺T cells into a SCID mouse caused intestinal inflammation. Manifestation of the disease was characterized by diarrhea and weight loss, showing chronic transmural inflammation, resembling the pathology of human Crohn's disease.

Table 3. Mouse models of colitis. Modified from Pizarro, *Trends of molecular Medicine*, vol 9, 2003 and Jurjus. *J. of Pharmacological Methods*, vol 50, 2004

Animal model	Disease type	Ref
<u>Chemically induced</u>		
TNBS (SJL/J mice)	Colitis, acute, chronic, transmural, Th1	(173)
TNBS (BALB/c mice)	Th2 colitis	
DSS	Colitis, superficial, Th1 (acute), Th2/Th2 (chronic)	(174)
Oxazalone	Colitis, Th2	(175)
<u>Adoptive transfer models</u>		
CD4+CD45RBhigh SCID transfer	Colitis, chronic transmural, Th1	(171, 172)
tge26 bone marrow chimera	Colitis, Th1	(176)
<u>Gene Knock out models</u>		
IL-10 KO	Colitis, acute, chronic, transmural, Th1(early)/Th2 (late)	(177)
TNF ^{ΔARE}	Ileocolitis, chronic, Th1, transmural	(81)
Gαi2 ^{-/-}	Granulomatous Chronic>acute	(178)
<u>Spontaneous</u>		
C3HHeJBir	Colitis, superficial, acute-resolving, Th1	(179)
SAMP1/Yit	Ileitis, chronic, transmural, granulomatous, Th1	(180)
<u>Transgenic mice</u>		
IL-7	Th1, UC-like	(181)
STAT-4	Th1, inflamed colon	(182)

AIMS OF THIS THESIS

To improve our understanding of the role of the mucosal fibroblasts in intestinal inflammation by analysing the molecular signalling mechanisms underlying their inflammatory potential.

The specific aims were:

- To study the CD40 expression on normal and inflamed mouse fibroblast cell lines and characterize their differences in proinflammatory potential after ligation with CD40L
- To characterize the molecular mechanisms underlying the synergy between CD40 and IFN- γ in inflamed cells.
- To investigate the possibility that activated inflamed cells have an increased capacity to promote T cell survival in intestinal inflammation
- To examine the hypothesis that increased accumulation of extracellular matrix components in chronic intestinal inflammation results from altered signalling from the TGF- β -R in activated fibroblasts

GENERAL MATERIALS & METHODS

For a more complete description of the different methods used during this thesis, detailed methods can be found in each paper and manuscripts included at the end of this thesis.

Cell lines (Papers I-IV)

Throughout this thesis we use fibroblasts cell lines isolated from normal Balb/c colon (normal) and colon tissue from a CD4⁺ CD45RB^{high}-transplanted C.B-17 (congenic with Balb/c) SCID mouse (inflamed). The isolation is done by cutting open the colons and washing them vigorously in cold PBS. Mucus and epithelial cells are scraped off by the use of a scalpel and the remaining tissue is cut in small pieces. The pieces are washed with medium and seeded in six-well plates. Four cell lines were derived by outgrowth in culture. They were grown in α -MEM supplemented with heat-inactivated 10% FCS, penicillin/streptomycin, gentamicin and L-glutamine in uncoated Falcon tissue culture flasks at 37°C under 5% CO₂-95% air until confluent, between 5 to 7 days. Cells were treated with trypsin EDTA to allow dissociation and they were re-seeded at 1 in 20. They were analysed between passages 5-25.

Cell stimulations (papers I-II)

In paper I, normal or inflamed colon fibroblasts were stimulated with IFN- γ and sCD40L in order to study the effects on expression of CD40 receptor and production of proinflammatory cytokines. In short, cells were grown in medium. After confluence at 5-7 days, cells were incubated with or without 200U/ml mouse recombinant IFN- γ in α -MEM supplemented with 0.1% FCS for 24 h. Cells were washed x3 with PBS and murine soluble CD40Ligand was added at 0; 0.1; 1.0 and 10.0 μ g/ml for 24 h in 0.1% FCS supplemented medium. After 24 h, supernatants were removed, centrifuged for 5 min at 220 g to remove debris and stored at -70 °C. In paper II, all cell lines were stimulated for 24 h with IFN- γ and sCD40L to study the effects of these stimulations on the expression of C/EBP β and the binding of NF κ B binding to consensus sites in the DNA.

Flow cytometry analysis, FACS (paper I and III)

In order to detect different markers and so characterize the phenotype of the fibroblast cell lines used during this thesis, flow cytometry was used. In paper I we were interested in studying the expression of CD40 receptor on both normal and inflamed cell lines before and after stimulations with 0, 100 or 200 U/ml of mouse recombinant IFN γ for 24 h. After incubation, cells were treated with trypsin/EDTA, resuspended in medium and washed by centrifugation. Aliquots of 10^5 cells/100 μ l were stained with fluorescein isothiocyanate (FITC)-conjugated hamster anti mouse CD40 monoclonal antibody (clone HM40-3) or with the same concentration of appropriate isotype control for 60 min.

In paper III, flow cytometry was used to study CD4⁺ T cell apoptosis. In this case, the expression of Annexin V was assessed to detect apoptotic CD4⁺ T cells. Briefly, CD4⁺ T cells were washed twice in ice cold PBS and resuspended in 100 μ l 1x binding buffer. Annexin V was added to each sample and incubated for 15 min at room temperature in the dark. After incubation, cells were analyzed within 1h by flow cytometry. Allophycocyanin (APC) conjugated rat anti-mouse CD4 antibody (L3T4), was used to determine the purity of CD4⁺T cells and to identify CD4⁺ T cells.

Immunohistochemistry (IHC) (papers I and manuscript IV)

In paper I we used IHC to localize the expression of CD40 and collagen I on fibroblasts in normal and inflamed tissue.

Cryostat sections (5-6 μ m) of colon tissue from normal Balb/c mice, non-transplanted C.B-17 SCID mice and C.B-17 SCID mice 6 weeks after transfer of 4×10^5 CD4⁺CD45RB^{high} Balb/c spleen cells were air dried and fixed at 4°C in 100% ice-cold acetone for 10 min. The slides were air dried for 5 min followed by 5 min re-hydration in PBS. Slides were incubated for 30 min with 10% normal donkey serum and 10% normal goat serum in PBS for 30 min to block non-specific binding, washed x3 and blocked with Avidin/Biotin. Tissues were double stained with rat anti-mouse CD40 (20 μ g/ml), isotype control rat IgG_{2a} and rabbit anti-mouse collagen I (1:100), or rabbit IgG as control, all diluted in PBS with 2% BSA and incubated overnight at 4°C, followed by washing.

Tissues were then incubated with biotinylated donkey anti-rat (1:200) for 1h at room temperature, washed and incubated with goat anti-rabbit-FITC (1:200) and Streptavidin-Texas red for 1 h at room temperature. The slides were washed and mounted with Vectashield.

In manuscript IV, HIC was used in order to localize the expression of TGF- β BII and confirm its localization with fibroblasts both in normal and inflamed tissue. A detailed list of the primary antibodies used for co-localization can be found in manuscript IV Table denominated primary antibodies.

Samples were placed on cork discs covered with OCT and snap frozen in isopentane cooled over liquid nitrogen and were stored at -70°C . Five micron sections for immunohistochemistry from all groups of mice were cut at -20°C on to the same slide and air dried. Sections were fixed in acetone at 4°C for 10 minutes and then rehydrated in PBS for 10 minutes. Staining for TGF- β RII, RI, α -smooth muscle actin (SMA), plasminogen or vimentin was enhanced by a 10 second pre-treatment in 50% (v/v) methanol /PBS. Non-specific binding was blocked with 10% (v/v) normal goat serum or 10% normal donkey serum, in PBS for 1 hour at 20°C , followed by an avidin/biotin block. To block endogenous mouse immunoglobulins when using mouse primary antibodies, the M.O.M. blocking kit was used according to manufacturer's instructions, with either the supplied biotinylated secondary, or with isotype-specific fluorochrome-conjugated goat secondary antibodies. Primary antibodies, or isotype-matched control immunoglobulins, were diluted in PBS and usually applied at 4°C overnight. As a further negative control for RI and RII, primary antibody was incubated with five-fold excess of immunising peptide for 3 hours at 20°C before application to the sections. Secondary antibodies were biotinylated goat anti-rat 1:200, donkey anti-rabbit (1:500), and donkey anti-goat (1:250). Where possible, multiple primary or secondary antibodies for dual or triple immunofluorescence were added together. However, when two biotinylated secondaries were used, one was applied first followed by streptavidin FITC (1:300), then a second avidin/biotin block and then the second biotinylated secondary was added, followed by streptavidin-Texas red (TXRD) (1:100), or avidin AMCA (1:100). When

two rabbit primary antibodies were used, the antigen giving the weakest signal using optimised conditions was incubated first with the relevant primary overnight and then developed with goat anti-rabbit (Fab fragment) conjugated with FITC (1:200). The second rabbit primary was then added to the sections and incubated at 20°C for 1 hour and then incubated with biotinylated donkey anti-rabbit IgG (1:1000) for 1 hour followed by streptavidin-Texas red. Some slides were developed using ABC complexes and peroxidase with DAB as substrate, as previously described. Cells grown on chamber slides were washed three times in PBS, air dried for 1 hour and then treated identically to tissue sections.

Luminex (paper I)

In paper I, we were interested in studying the effects of cross-linking between CD40 receptors and sCD40L in the production of cytokine/chemokines by both normal and inflamed cells. Here we used Luminex, LINCOPlex KIT, which allows the detection of several products at the same time. In this case the cytokine/chemokines detected were; IL-6, CCL2, CCL3, CCL5, IL-12 and TNF- α . In brief; cytokine production was detected in cell culture supernatants using a 96-well plate assay, which was blocked with 200 μ l of assay buffer on a shaker for 10 min at room temperature. Assay buffer was removed and appropriate standards, controls, blanks, samples and mixed beads were added. The plate was incubated on a plate shaker overnight at 4°C. After incubation, fluid was removed and the plate was washed twice. After removal of wash buffer by vacuum filtration, detection antibody cocktail was added to each well and the plate was incubated for 60 min at room temperature. Streptavidin-Phycoerythrin 25 μ l was added directly to each well and incubated on a plate shaker for 30 min at room temperature. After washing and filtration, 100 μ l of sheath fluid was added to each well and shaken on a plate shaker for 5 min. Samples were read and analysed using a Bio-Plex Manager system.

SDS-PAGE Western blot (manuscript II and IV)

Western blot is a method that is used to detect and identify different proteins in cell lysates using antibodies. In papers II and IV this method was used to detect the

expression the transcription C/EBP β , phospho-C/EBP β , phospho-Jak2, p65/NF κ B, IFN- γ R β , Smad 2/3 and Smad 7.

According to where in the cell the protein of interest is localized, different lysis procedures are performed - cytosolic, nuclear and whole cell extracts. Lysates were generally prepared from 10^7 cells/ml. After lysing cells in appropriate buffers cells were centrifuged at 10,000 for 5 min and lysates were either used immediately or freezed at -80°C.

For immunoprecipitation studies on cytoplasmic, nuclear or whole cells extracts, lysates were incubated with titrated pull-down antibodies for 90 min at 4°C. Pre-cleared anti-rabbit IgG agarose beads were added and incubated for 60 min at 4°C in a shaker. Beads were collected after centrifugation at 3,000g at 4°C for 2 min and washed x3 in ice cold lysis buffer. Immunoprecipitates were recovered by re-suspending beads in loading buffer, heating at 95°C for 5 min, and centrifuging at 12,000 g for 30 sec at room temperature, and were then stored at -80°C.

Total protein concentration in lysates was determined using BCATM Protein Assay. Equal amounts of protein were loaded in each well of 10% or 12% SDS-PAGE mini-gels and electrophoresed. Gels were blotted to Immun-Blot PVDF membrane using a semi-dry blotter 90 min. Membranes were blocked either with 5% bovine serum albumin or with 0.05% non-fat dry milk in PBS/0.05%Tween on a rocker for 60 min. Detection of proteins of interest was carried out by incubation of primary antibodies: rabbit anti-C/EBP β , rabbit anti-phosphothreonine, rabbit anti-phospho-Jak2 , goat anti-NF κ B p65 or IFN- γ receptor beta overnight at 4°C. Extract of 3T3 L1 Adipocytes was used as positive and negative controls to detect phosphorylated Jak2, and murine A20 B cells were used as an extract control for positive and negative detection of IFN- γ receptor beta. Primary antibodies were detected by incubation with goat anti-rabbit IgG-HRP antibody or donkey anti-goat IgG-HRP antibody. All membranes were visualized by enhanced chemiluminescence using ECL reagent. Blots were stripped with 50mM Tris-HCl pH 6.8, 2% SDS, 100mM 2- β -mercaptoethanol at 50°C for 30 min. Blots were extensively rinsed in water and blocked with 0.05% non fat dry milk PBS/0.05% Tween, or 5% BSA in

PBST for one hour, before re-probing. Protein quantification was made by densitometric analyses of intensity using Kodak 1D v 3.5.3 software and densitometry analyses was performed by correcting the values with loading controls for each protein.

Isolation of CD4⁺ T cells (manuscript III)

In order to characterize the anti-apoptotic effects of fibroblasts on CD4⁺ T cells, CD4⁺ T cells were isolated by negative selection using a CD4⁺ T cell isolation kit. Briefly, spleens from Balb/c mice were forced through a cell strainer, washed twice with ice cold MACS buffer and treated with red blood cell lysis buffer for two minutes at room temperature. The lysis of red blood cells was stopped by adding MACS buffer. Cells were filtered and washed twice for 5 min with MACS buffer. Cells were resuspended in MACS buffer and incubated with biotinylated antibody cocktail at 4°C for 10 min. Anti-biotin beads were added to the solution and incubated for 15 min at 4°C. Magnetically labeled cells were discarded and the negatively selected cells were collected. The T cells were resuspended in medium consisting of RPMI 1640, 25mM HEPES, penicillin/streptomycin, 200mM L-glutamine and 5% FCS. Isolation of CD4⁺ T cells resulted in a purity of 90-98% as determined by FACS analysis. Viability of cells was determined by trypan blue and showed a viability of 95%.

Fibroblasts and CD4⁺ T cell co-cultures (manuscript III)

Normal and inflamed fibroblasts (10⁴ per well) were grown in 96-well plates in triplicates. Twenty four hours later 2 x10⁵ CD4⁺ T cells were added to wells with and without (controls) fibroblasts. Cells were cultured in medium consisting of RPMI 1640, 25mM HEPES, penicillin/streptomycin, 200mM L-glutamine and 5% FCS. Phytohemagglutinin (PHA) (5µg/ml) with or without interleukin (IL)-2, 50 units/ml conditioned supernatant from X63Ag8-653 cell line was added to cultures to activate T cells. Control co-cultures received neither PHA nor IL-2. CD4⁺ T cells were also cultured with fibroblast conditioned medium. Fibroblast culture supernatants were collected from cells which, when confluent, were allowed to grow in medium containing 0.1% FCS. After 48 h supernatants were collected and centrifuged to remove cell debris. Co-cultures were incubated for four days at 37°C under 5% CO₂-95% air. After this

incubation time non-adherent T cells were removed from the adherent fibroblast monolayer for flow cytometric analyses.

T cell proliferation assays (manuscript III)

T cell proliferation was studied by labeling 10^7 CD4⁺ T cells with CFSE (5 μ M), Vybrant CFDA SE cell tracer kit in 1.5 ml PBS and incubated at room temperature for 8 min in the dark. The reaction was stopped by adding 1.5 ml FCS. Cells were washed twice and resuspended in RPMI 1640, 25mM HEPES, penicillin/streptomycin, 200mM L-glutamine and 5% FCS and were ready to be used in co-cultures.

Luciferase reporter assays (manuscript IV)

The potential for TGF- β 1 to activate Smad-dependent promoters and the collagen type I promoter was examined using the plasmids pSBE.Luc and col-1-luc, respectively, comprising either a minimal promoter plus 4 tandem repeats of the Smad binding element (SBE), or the entire COL1 promoter, which when activated drive the expression of the luciferase gene.

Cells were grown to approximately 50% confluence in 12 well plates. For each well, 100 μ l serum-free medium and 3 μ l FuGene 6 transfectant reagent were placed in an eppendorf. Into a second eppendorf, 0.5 μ g pSBE-luc, or col-1-luc, was mixed with 0.5 μ g *Renilla* luciferase control vector pRL-TK. The contents were left to stand for 5 minutes at room temperature, after which they were mixed gently and left to stand for a further 15 minutes. The medium was decanted from the cells and replaced with 2 ml DMEM containing 1% (v/v) FCS. 100 μ l Fugene/DNA mix was added to each well and incubated at 37°C for 6 hours. Cells were treated with TGF- β 1 (1 ng/ml) or diluent and incubated for a further 16 hours at 37°C. Medium was decanted and 100 μ l 1x lysis buffer was added to each well and the resulting lysate placed into eppendorfs and stored at – 20°C until required. After one freeze-thaw cycle and centrifugation at 13000g for 5 minutes, samples were assayed sequentially for the Firefly and *Renilla* luciferase activity using the Dual Luciferase assay kit. 20 μ l crude cell lysate was incubated with 100 μ l luciferin reagent (LarII). After 15 seconds at room temperature, the luminescence was

recorded for 30 seconds in a Berthold Lumat LB9507 luminometer. 100 μ l Stop and Glo reagent was added and the specific luminescence from the *Renilla* luciferase recorded for an additional 30 seconds. The relative luciferase activity, indicative of reporter gene transactivation, was calculated by expressing the firefly luciferase luminescence as a ratio of the *Renilla* luciferase luminescence.

Real-Time PCR (manuscript IV)

Real-time PCR was used in manuscript IV to analyze the collagen 1 transcript expression by normal and inflamed cells. Cells were grown in 10% FCS until 75% confluent. The medium was replaced by medium containing 0.5% FCS for 24h. Normal and inflamed cells were then stimulated with 1ng/ml of TGF- β 1 for 0, 4, 8, 16, 24 and 48 hours. After treatment, cells were washed twice in cold PBS and centrifuged at 3,000 rpm at 4°C for 5 minutes. Cells were kept at -70°C until preparation of total RNA.

Total RNA was prepared using an RNeasy Mini kit according to the supplier's protocol. Total RNA (2 μ g) was reverse-transcribed in a 30 μ l volume containing 100pmol (3.3 μ M) random hexamer, 10mM dNTPs each Superscript 200U/ μ l (RNase H-Reverse Transcriptase), 40U/ μ l RNase inhibitor for 1hour at 42°C followed by inactivation at 70°C for 10 min.

Murine collagen 1 transcript expression was quantified using a LightCycler rapid thermal system according to the manufacturer's instructions. mRNA expression for each sample was normalized against murine hypoxanthine guanine phosphorybosyltransferase (HPRT) mRNA used as housekeeping gene (LightCycler-Primer Set Kit). The specific primers used for collagen 1 were designated: Mus Col1A1 forward primer 5' CTG AAG TCA GCT GCA TAC ACA ATG 3' and Mus Col1A1 223 reverse primer 5' GGT TGG GAC AGT CCA GTT CTT C 3'. Real-time PCR was performed in glass capillaries (Roche) in a final volume of 20 μ l containing 15 μ l of LightCycler FastStart DNA Master^{Plus} SYBR Green I master mix (Roche) (4 μ l SybrGreen mix, 1 μ l of each specific primer at 0.2 μ M, 9 μ l dH₂O) and 5 μ l cDNA. Real-time PCR was conducted with an initial denaturing step of 15 min at 95°C, followed by 45 cycles of: amplification at 95°C for 10s, 65°C for 10s,

72°C for 6s, 1 cycle of melting at 95°C for 0s, 65°C for 15s, 95°C 0s and finally one cooling cycle at 40°C for 30s. PCR product was subjected to melting curve-analyses for the confirmation of the specificity of the product. For relative quantification of the concentration of collagen 1 gene expression, the crossing point (CP) values were used. Results were expressed as a ratio between the CP of the housekeeping gene and the CP for collagen gene in each sample.

RESULTS AND COMMENTS

Paper I and manuscript II

Colonic fibroblasts and CD40

The starting point for these studies was the observation by Whiting et al. (2003) (50) that, in both human colitis and in the CD4⁺-transplanted SCID mouse model of colitis, the tissue mesenchyme shows signs of activation – specifically, that the subepithelial myofibroblast syncytium increases in size and upregulates expression of the high affinity receptor for TGF- β , and that both myofibroblasts and fibroblasts in the inflamed tissue change expression of matrix proteins. This posed the question: “By what mechanism(s) do these mesenchymal cells become activated and, in their activated state, can they contribute directly to the inflammatory pathology?”

With regard to the mechanism of activation, results in many laboratories (113, 115, 133) investigating inflammation in several tissues had shown that subpopulations of mesenchymal cells expressed the TNFR superfamily member, CD40, which has been implicated in multiple activation process in many cell types, principally through STAT, NF κ B and NFAT pathways (125). This, then, formed the basis of a hypothesis that activation of fibroblast subpopulations through CD40 resulted in their participation in the inflammatory response in the gut.

Initial studies asked whether CD40 was expressed on fibroblast populations in normal and inflamed colon. Using collagen I as a marker for fibroblasts, we could detect the presence of cells co-expressing collagen I and CD40 in normal tissues. In inflamed tissue, collagen I⁺ fibroblasts either did not express CD40, or expressed at such a low level that was not detected at the sensitivity of immunohistochemistry (Fig. 1, paper I).

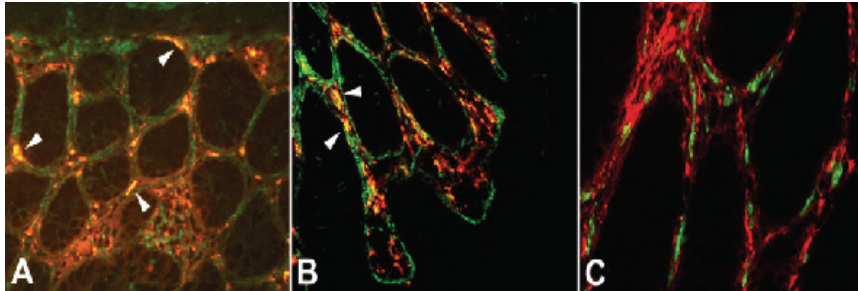

Fig. 1 from paper I. *In situ* CD40 expression by in normal and inflamed mouse colon. A, Balb/c mouse colon; B, SCID mouse colon; C, inflamed SCID colon. CD40 (red); collagen I (green).

With the evidence that CD40 is expressed by mesenchymal cells in the mouse colon, the next challenge was to devise a system to study its function in inflammation. To this end, fibroblast cell lines were produced by outgrowth from normal and inflamed mouse colon tissue segments. These cell lines provided a model system for studying fibroblast CD40 and the consequences of its ligation. Firstly, the density of expression of CD40 was investigated using flow cytometry.

Fibroblasts from normal colon expressed CD40 constitutively as three overlapping subpopulations, based on density of expression. Surprisingly, in view of their level of activation in colitis, but accordance with the *in situ* results from immunohistochemistry, cells derived from inflamed colon consisted of a more homogenous population of cells that expressed the CD40 receptor at a low intensity (Fig 2, paper I, not shown).

Previous work had shown that fibroblast CD40 can be upregulated by the effects of IFN- γ (69, 113, 114). Stimulation of normal and inflamed fibroblast lines showed that only normal cells were able to upregulate CD40, inflamed cells essentially did not respond (Fig. 5C and D, paper I).

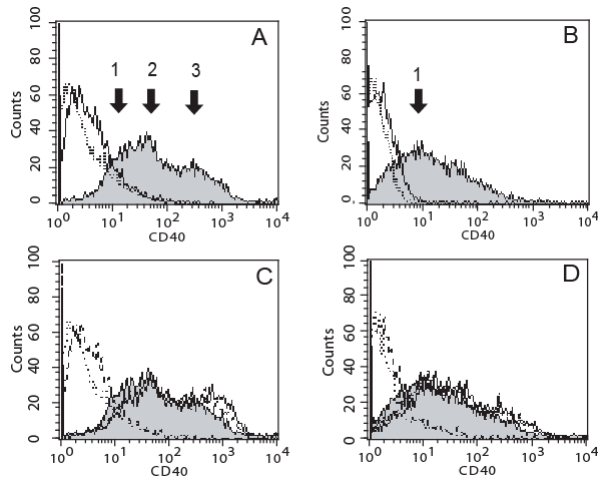

Fig. 3 and 5, from paper I. Subpopulation analysis of CD40 expression on fibroblasts lines from normal (A) and inflamed (B) mouse colon. Arrows indicated the existence of different subpopulations. Normal (C) and inflamed (D) fibroblasts treated for 24h with IFN- γ .

Thus, within the complex cell lines, fewer fibroblasts from normal mucosa expressed CD40 at high levels than fibroblasts from inflamed mucosa and those from inflamed mucosa were less responsive, in terms of CD40 induction, than normal fibroblasts. This was not expected and stimulated the question “How does this affect the responses to ligation of the CD40 receptor?”

To study this, the secretion of a range of proinflammatory cytokines and chemokines in response to CD40 ligation was measured. Surprisingly, considering their lower level expression of CD40, inflamed cells were more efficient in producing proinflammatory cytokines/chemokines compared to normal cells. Normal cells showed minimal production of any of the cytokines/chemokines studied until they were stimulated with the highest concentration of sCD40L, together with pretreatment with rmIFN- γ . IL-6 responses and CCL5 responses were very similar: normal cells responded very little, only at high CD40L concentration amplified by IFN- γ ; inflamed cells secreted significant constitutive levels which were increased by CD40 ligation and showed dramatically

increased secretion when pretreated with IFN- γ , in a CD40 dose-dependent manner. With regard to CCL2: secretion by normal cells was, again, minimal; in inflamed cells, there was significant constitutive secretion, very little additive response with CD40L, but a significant response to IFN- γ pretreatment which, this time, was not CD40 dose-dependent. The CCL3 response was different again: in both normal and inflamed cells, there was no constitutive secretion, significant secretion at the highest concentration of CD40L and, as with IL-6 and CCL5, this CD40 response was synergised by IFN- γ (Fig 8, paper I).

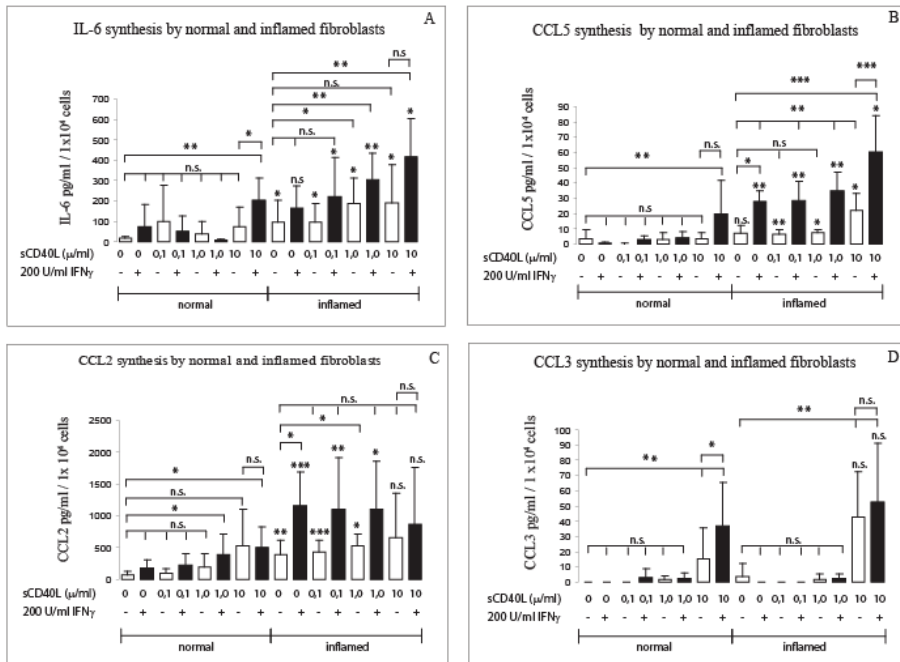

Fig. 8 from paper I. Secretion of proinflammatory cytokines/chemokines by fibroblasts lines from normal and inflamed mouse colon and effects of CD40 ligation, with and without pretreatment with IFN- γ . Stimulations with (+, solid bars) or without (-, open bars) IFN- γ and with or without sCD40L (0; 0.1, 1.0 and 10 μ g/ml) for 24 h. (A) Interleukin 6, (B) CCL5, (C) CCL2 and (D) CCL3. Bars represent means \pm s.d. of duplicated values from three separate experiments. *P < 0.05, **P < 0.001, ***P < 0.0001; n.s. not significantly different.

Thus, fibroblasts from inflamed colon have relatively low levels of CD40 expression, but respond in most cases more vigorously to ligation of CD40 than cells from normal colon with higher levels of CD40. This enhanced response is upregulated in the presence of signalling from IFN- γ – the principal effector T cell cytokine present in the tissues in this mouse model of colitis.

These observations provoked the question, “What mechanisms could be responsible for potentiating the CD40 proinflammatory response and its amplification in the presence of IFN- γ ?” Literature search indicated that the transactivation effects of the transcription factor, C/EBP β , could be implicated.

Manuscript II

The C/EBP β story

The transcription factor C/EBP β has been shown to be involved in many biological control mechanisms; cell proliferation (183), control of metabolism, inflammation (39). Its capacity to build complexes with other transcription factors such as NF κ B (140, 150), allowing so the transactivation of various genes, caused us to investigate its influence on fibroblast proinflammatory mechanisms.

We started our investigation by studying the expression of C/EBP β in both cell lines. The results showed that inflamed fibroblasts had much higher constitutive levels of C/EBP β than normal fibroblasts (Fig 1, manuscript II). Only in normal fibroblasts was the constitutive C/EBP β influenced by IFN- γ pretreatment. When C/EBP β is phosphorylated, it is able to enter the nucleus and start the transcription of various genes (148, 184). Surprisingly, despite the higher constitutive levels of C/EBP β in inflamed fibroblasts – which was indicative of activation – there was no difference in phosphorylation levels between the two cell lines (Fig. 2, manuscript II, data shown)

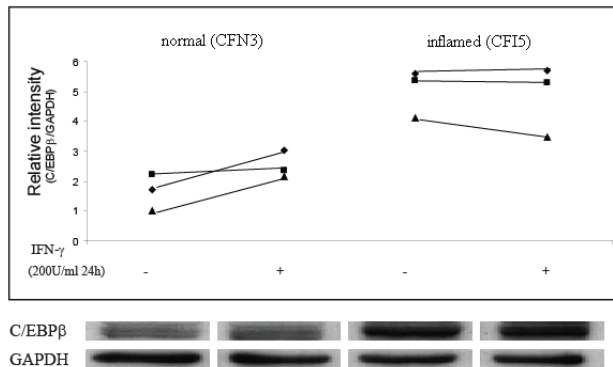

Fig. 1 from manuscript II. Expression of C/EBP β . Western blot analyses of normal (CFN3) and inflamed CFI5 colonic fibroblasts for cytosolic expression of C/EBP β . Stimulations with or without rmIFN- γ for 24 h. Protein quantification was made by densitometric analyses on relative intensity of expression of C/EBP β compared to GAPDH.

This disconnect between the CD40/IFN- γ response data and the apparent lack of activation of high levels of C/EBP β in inflamed cells treated with IFN γ caused us to ask “Does the IFN- γ R function in the normal way in fibroblasts from inflamed mucosa?”

Signalling from the IFN- γ R

Firstly, IFN- γ receptor β , which is the part of the receptor that is responsible for signal transduction (136, 185) was examined. Results show that both inflamed cell lines studied expressed lower levels of IFN- γ R β and that stimulation with rmIFN- γ probably lowered this expression further. Normal cells, on the other hand, showed much higher levels of expression of the receptor although, again, this was apparently downregulated after ligation (Fig. 3, manuscript II).

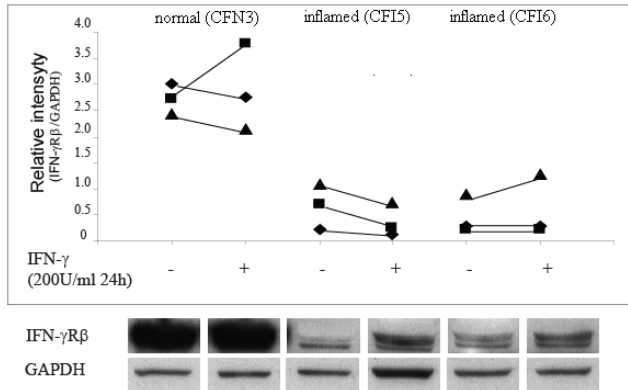

Fig. 3 from manuscript II. IFN- γ receptor beta chain (IFN- γ R β) expression on normal (CFN3) and inflamed (CFI5 and CFI6) colon fibroblasts. Whole cell lysates were prepared from cells stimulated with or without rmIFN- γ for 24 h. Densitometric analyses was based on relative intensity of expression of IFN- γ R β compared to GAPDH.

What effect, then, does this have on signalling events downstream of the receptor? To answer this, we next studied the ability of the cell lines to phosphorylate Jak2 after stimulation with rmIFN- γ . Surprisingly, both inflamed cell lines showed a higher constitutive expression of phosphorylated Jak2, a phosphorylation that was also increased after stimulation with rmIFN- γ . Phosphorylation of Jak2 by normal cells was less affected by IFN- γ stimulation (Fig. 4, manuscript II).

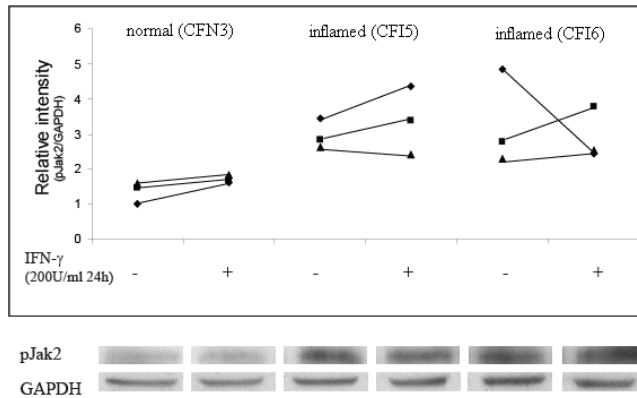

Fig. 4 from manuscript II. Phosphorylated Jak2 expression on normal (CFN3) and inflamed (CFI5 and CFI6) colon fibroblasts. 24h stimulations with or without rmIFN- γ . Protein quantification was made by densitometric analyses on relative intensity of expression of phosphorylated Jak2 compared to GAPDH.

The NF κ B response

In the initial CD40 stimulation experiments (Fig. 8, paper I), the CD40/IFN- γ potentiation of proinflammatory responses were noted particularly for IL-6 and CCL5, two cytokines/chemokines known to be under transcriptional regulation of NF κ B (186-188). We therefore examined nuclear binding of NF κ B to its consensus sequence after CD40 stimulation. The results showed that inflamed cells have a higher constitutive level of NF κ B binding and that this is upregulated by CD40 ligation. In comparison, the response in fibroblasts derived from normal mucosa was very weak (Fig. 5, manuscript II).

Clearly, then, the proinflammatory potential in response to CD40L can be attributed, at least in part, to NF κ B activation, but this does not explain why this should be the case in cells with lower levels of CD40 expression. In the final part of this section of the thesis, attempts were therefore made to link the CD40/IFN- γ /NF κ B data to the IFN- γ /C/EBP β data.

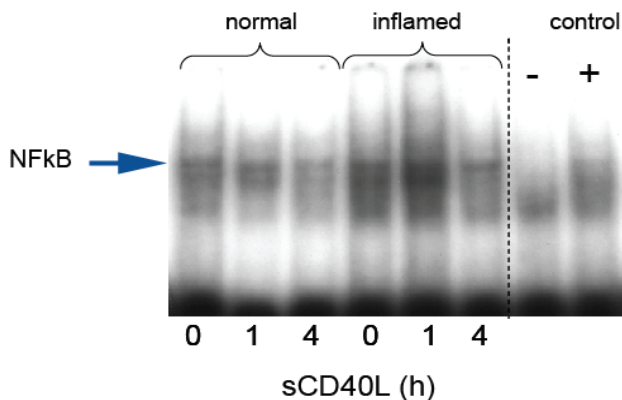

Fig. 5 from manuscript II. EMSA assay of NFκB DNA binding activity in normal (CFN3) and inflamed (CFI5) colon fibroblasts with ligation of sCD40L. Nuclear extracts were prepared from normal and inflamed cells stimulated with sCD40L (10 μg/ml) for 0, 1 and 4 hr incubated with a [γ - 32 P]-ATP endlabelled NFκB oligonucleotide and analyzed with the electrophoretic mobility shift assay. Representative result of 3 separate experiments.

Linking NFκB and C/EBPβ

It is known (142, 150) that C/EBPβ can build complexes with NFκB in the nucleus which results in the transactivation of genes. Expression of C/EBPβ in the nucleus and its ability to bind to NFκB, were therefore investigated. As demonstrated in Fig. 6, manuscript II, contrary to normal cells, inflamed cells constitutively expressed C/EBPβ at 45 kDa (Fig. 6 ii) and 160 kDa (Fig. 6 i) without rmIFN-γ stimulation. Treatments with rmIFN-γ showed an upregulation in expression of C/EBPβ in normal cells, while inflamed cells showed an increased intensity of the constitutively expressed C/EBPβ. Stripping the blots and probing them with p65/NFκB, showed that only inflamed cells, and especially after IFN-γ treatment, were they able to build complexes between C/EBPβ and p65/NFκB, as demonstrated by the expression of p65/NFκB (Fig. 6 iii).

These data clearly indicate that the synergetic effect seen between IFN-γ and sCD40L stimulations shown in paper I, depend on the increased constitutive expression of

C/EBP β and NF κ B in the nucleus, allowing these transcription factors to complex and thus transactivate genes.

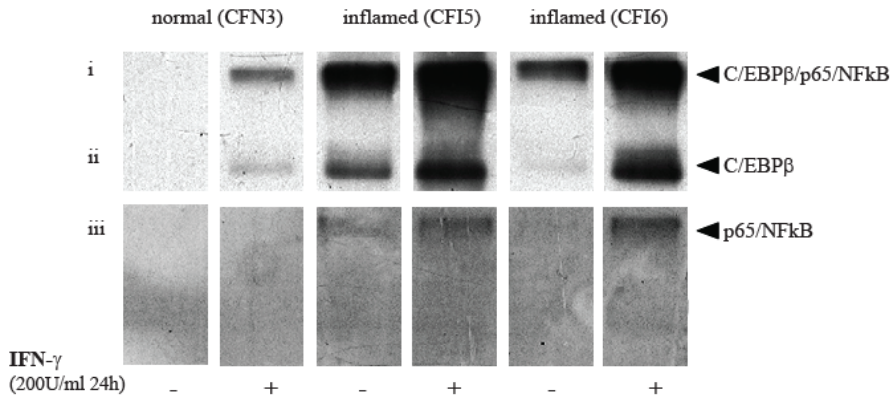

Fig. 6 from manuscript II. Detection of complexes of C/EBP β /p65/NF κ B on normal (CFN3) and inflamed (CFI5 and CFI6) colon fibroblasts treated with or without rmIFN- γ for 24h. Nuclear lysates were immunoprecipitated with rabbit anti-C/EBP β . Blots were probed with rabbit anti-C/EBP β showing expression of C/EBP β at 160 kDa (i), C/EBP β at 45 kDa (ii) and stripped blot probed with anti-p65/NF κ B confirming complexes within the 160 kDa band (iii). Representative result of 3 separate experiments

Manuscript III

Rescue from CD4⁺ T cell apoptosis by normal and inflamed fibroblasts

As confirmed by the data shown this far, fibroblasts isolated from inflamed mouse colon display a phenotype that can be characterized as an activated phenotype. Contrary to normal cells, inflamed fibroblasts responded more vigorously to stimulation, a response that depended on the synergistic action between C/EBP β and NF κ B. Our next question was: “Does this activated phenotype represent one of the factors responsible for the persistence of activated intestinal CD4⁺ T cells in of the mucosa in IBD (31). Previous work has shown that fibroblasts from synovial, skin and bone marrow tissue could prevent apoptosis of CD4⁺ T cells (95, 189). So next we studied the anti-apoptotic effects of normal and inflamed fibroblasts.

As the data indicates in Fig. 1C, manuscript III, both normal and inflamed cells were able to prevent CD4⁺ T cells from dying and both cell lines were equally efficient in doing so. This survival was not only a result of cell to cell contact, but as seen Fig. 2, both cell lines produced soluble factors that prolonged the life of CD4⁺ T cells. These anti-apoptotic effects did not depend on T cell proliferation as no proliferation could be seen in our experiments (Fig. 3, manuscript III, data not shown).

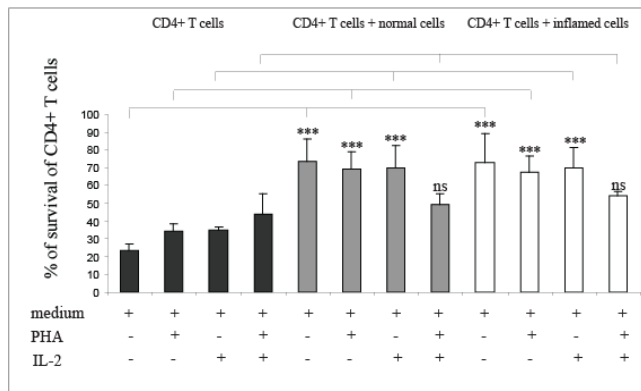

Fig. 1C from manuscript III. Percentage of survival of CD4⁺T cells in co-cultures with normal and inflamed colon fibroblasts. CD4⁺T cells alone (black bars), CD4⁺T cells and normal fibroblasts (grey bars), CD4⁺T cells and inflamed fibroblasts (white bars). Stimulations: PHA was used at a concentration of 5ng/ml and IL-2 at 10%. The co-cultures were maintained for 4 days. Three experiments with each sample in triplicates. The values are mean \pm SD. Differences from CD4⁺T cells alone: *** $P < 0.001$, ** $P < 0.01$, * $P < 0.05$, ns, not significantly different.

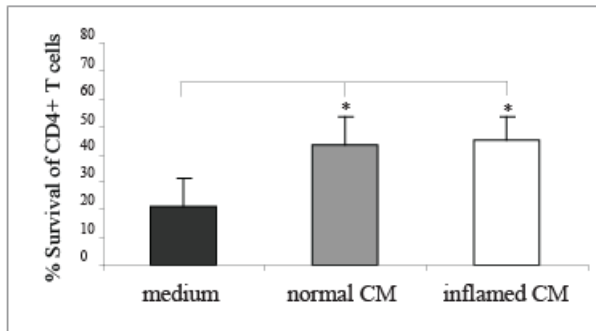

Fig. 2 from manuscript III. Survival of CD4⁺T cells cultured with conditioned medium collected from 48h culture of from normal cells (grey bar), inflamed cells (white bar), or medium only (black bar). Four day co-cultures. Values are mean ± SD (triplicate wells). Differences from medium only control: * $P < 0.05$.

Manuscript IV

Regulation of TGF- β -mediated collagen production by mesenchymal fibroblasts

It has previously been shown (50) that mesenchymal cells in the inflamed colon in the model of colitis used throughout this work have increased expression of TGF- β RII, and this is coincident with disrupted expression of extracellular matrix proteins collagen I and IV. Fibrosis is a pathological condition that affects CD patients and is characterized by the increase of ECM and can only be treated by surgical intervention (190). The causes of fibrosis are not known, but in an attempt to add some insights in the mechanisms behind the disease, we studied the effects of increased expression of TGF- β RII on ECM synthesis by activated fibroblasts in colitis.

In situ studies demonstrated that the upregulated expression of TGF- β RII was on putative fibroblasts and not on leukocyte populations (Fig. 2, manuscript IV).

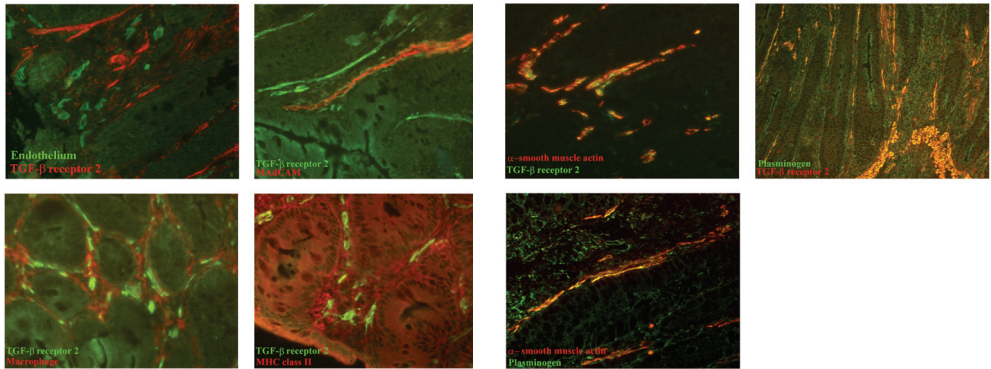

Fig. 2 from manuscript IV. Fluorescence immunohistochemical analysis of cells in colitis expressing TGF- β RII. Frozen sections of inflamed mouse colon were stained for TGF- β RII and endothelium, MadCAM-1, macrophage F4/80, MHCII, α -SMA, or plasminogen

The cell lines were used to investigate whether the disruption to the ECM was linked to increased TGF- β signalling – because of the receptor upregulation on activated fibroblasts. Surprisingly, results showed that inflamed fibroblasts responded less to TGF- β stimulations (Fig. 4, manuscript III).

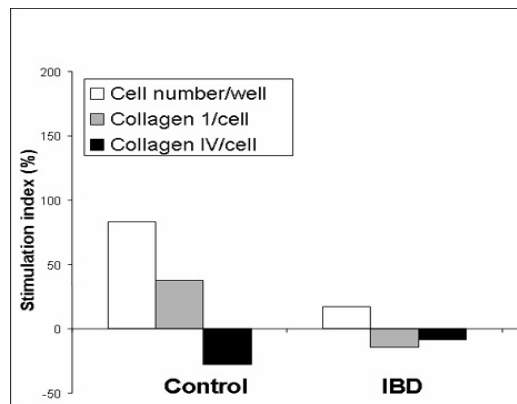
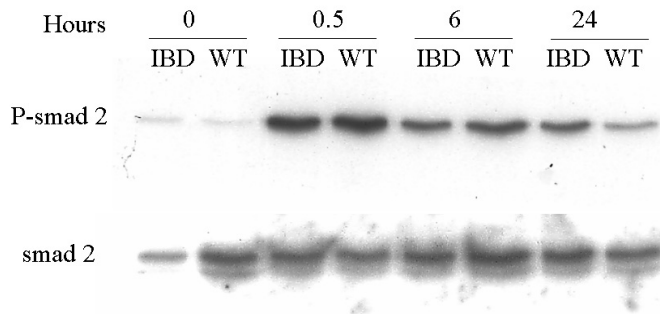

Fig. 4 from manuscript IV. Proliferative and collagen synthesis responses of normal and inflamed mouse colonic fibroblasts to stimulation with TGF- β 1. Proliferation was assessed by cell counting and collagen synthesis by ELISA. Representative results from five separate experiments.

Could these differences in the response to TGF- β between the cell lines depend on differences in the Smad pathway? Our data (Fig. 5A and B) show that this did not seem to be the case. We observed normal activation of Smad2 protein and no upregulation of inhibitory Smad7 in both cell lines.

A



B

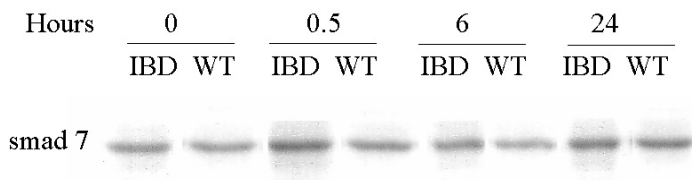

Fig 5A and B from manuscript IV. Analysis of Smad signaling in normal (WT) and inflamed (IBD) mouse colonic fibroblasts after stimulation with TGF- β 1. A) Total Smad2 and phosphorylated Smad2; B) Smad 7.

Preliminary experiments using SBE and collagen promoter reporter assays suggested that collagen transcription in activated cells in response to TGF- β was as in normal fibroblasts, so what about translation? Our preliminary data indicated that translation was no different despite the upregulated levels of an apparently functional receptor and intact signalling (Fig. 6A, B and Fig. 7A, B, manuscript IV, data not shown).

The data suggest that the enhanced and disrupted collagen production seen in the mouse model is not simply a result of enhanced collagen transcription/translation in response to enhanced TGF signalling. It may be that the answer is not related to increased production, but rather to decreased degradation by matrix modeling proteases. The group of Tarlton et al. (2000) has shown evidence that MMPs and serine proteases show major changes in this mouse model (191), although changes in specific proteases or their inhibitors which could account for the ECM changes seen have not yet been identified.

GENERAL DISCUSSION

The intention of this thesis was to investigate the inflammatory potential of gut mucosal fibroblast populations and to characterize the molecular mechanisms underlying their role in colonic inflammation.

For a long time, fibroblasts were considered to have one principal function - to produce extracellular matrix components to maintain tissue architecture. This assumption has been challenged and many studies have shown that they can also produce proinflammatory cytokines in response to micro-organisms or stimulation by cells involved in the immune response (75, 192)

The evidence given in this work clearly indicates that fibroblasts play a major role in some of the most common characteristics of IBD, such as amplification of the inflammatory response, chronicity and apoptosis.

Fibroblasts produce proinflammatory cytokines and chemokines after stimulation through CD40 receptor (113, 114), an important co-stimulatory molecule in IBD (193), upregulated in both CD and UC (21, 22, 194). This molecule has been shown to be upregulated on B cells, dendritic cell and monocytes in inflammation (19, 22, 195).

We show here for the first time, the existence of a population of colonic fibroblasts from inflamed tissue that, despite lower constitutive CD40 receptor expression, have acquired the capacity to produce higher concentrations of cytokines/chemokines when stimulated with sCD40L and IFN- γ , compared to fibroblasts from non-inflamed tissue. We showed also that, contrary to the data of others (109, 114), inflamed cells had a reduced capacity to upregulate CD40 expression after IFN- γ treatment. One important factor to keep in mind is that the inflamed fibroblasts used in this study were isolated from a colitic mouse model which resembles CD and is characterized by the increased production of IFN- γ . It is possible that this milieu either desensitizes the fibroblasts from the effects of IFN- γ after continued stimulation, or that fibroblast activation induces altered signalling through

IFN- γ R, which results in reduced CD40 transcription. With regard to the production of cytokines/chemokines, the effects of IFN- γ were different. Our results showed that treatment with IFN- γ before stimulation with sCD40L had a synergistic effect, increasing the production of cytokines/chemokines.

As a result of these data, which clearly indicated that fibroblasts taken from inflamed tissue displayed an activated phenotype, we investigated the mechanisms underlying this activated phenotype.

We showed that the activated phenotype displayed by inflamed fibroblasts depended on the constitutive expression of C/EBP β and NF κ B and their ability to complex in the nucleus. This complex formation was increased by the effects of IFN- γ . We also showed, unexpectedly, that although inflamed cells had lower expression of IFN- γ R β , they displayed a higher constitutive expression of phosphorylated Jak2.

How, then, can inflamed cells express higher constitutive levels of phosphorylated Jak2, while expressing lower surface membrane IFN- γ R β ? It was clear that inflamed cells were activated by additional mechanisms, probably through other signalling pathways.

A clue to these transactivating signalling pathways may be the observation of constitutive IL-6 production by inflamed cells. We speculate that the higher constitutive expression of phosphorylated Jak2 depends on an autocrine effect of IL-6 on inflamed cells (196, 197). Autocrine effects of IL-6 on fibroblasts have been demonstrated on lung fibroblasts by Fries et al. (1994) (90). Thus, signalling through the IL-6 receptor results in the phosphorylation of Jak2 and further phosphorylation and activation of STAT1 and STAT3 (146), allowing the formation of STAT3/STAT3 homodimers or STAT3/STAT1 heterodimers which enter the nucleus and bind to promoter elements for the transcription of STATs and C/EBP β . IL-6 has also been shown to activate the Ras-Raf pathway, which also results in the activation of C/EBP β (147). Like IL-6, IFN- γ can also activate STAT1 which, through the involvement of MAP kinase kinase 1 (MEKK1) and ERK1/2 signaling pathways, stimulates the expression of C/EBP β (164). MEKK1 is also involved

in the activation of NFκB (198, 199), which may explain, in part, the constitutive expression of NFκB in the nucleus due to signalling from the constitutively phosphorylated Jak2.

The involvement of IL-6 in all these activating pathways would reflect the activated phenotype of inflamed cells.

IL-6 production has also been shown to sensitize and potentiate CD40 signalling (200), which could explain the higher constitutive NFκB nuclear binding, making it possible for C/EBPβ to build a complex with NFκB and so increase the transactivation.

In IBD, IL-6 has also been shown to be upregulated both in serum and in tissue (201, 202), thus having an increased impact on various biological activities, including T and B cell differentiation, proliferation (203) and also in preventing T cell apoptosis, as shown by Teague et al. (1997) (204) in a mouse model. Atreya et al. (2000) (205) demonstrated that blocking of IL-6 signaling resulted in the induction of apoptosis, demonstrating the important role of IL-6 in homeostasis. Fibroblasts from several human tissues have been shown to prevent T cell apoptosis, not only through the effects of IL-6, but also by other factors such as IFN-β (206)

In paper I, we demonstrated that inflamed fibroblasts more efficiently synthesized cytokines/chemokines after ligation with sCD40L/IFN-γ and, moreover, showed constitutive production of IL-6 by the activated cells. We therefore investigated the possibility that these cells are more efficient in prolonging T cell survival than fibroblasts derived from normal tissue. Contrary to predictions, both cell lines were equally efficient in protecting CD4⁺ T cells from apoptosis. Even though inflamed cells did not show a stronger anti-apoptotic effect, inflamed fibroblasts proliferate much more rapidly than fibroblasts from normal tissue and so, even though both cell lines prevented T cell apoptosis, the greater number of activated fibroblasts in inflamed tissue would likely have a greater effect on T cell survival, maintaining T cells at sites of inflammation, and

influencing homeostasis in the intestine - a characteristic applying to both CD and UC (28, 31).

Another important aspect that characterizes IBD is the increased accumulation of collagens. Whiting et al. (2003) (50) showed that activated fibroblasts in the SCID mouse model of colitis increased expression of TGF- β RII. We speculated that on stimulation with TGF- β , these cells may be responsible for the accumulation of collagen seen in the model. Surprisingly, the fibroblast line derived from inflamed colon produced less collagen when stimulated with TGF- β .

We found no differences between control and inflamed fibroblasts at the levels of TGF- β signaling, or subsequent collagen transcription or translation. Our findings with C/EBP β , may explain these results. Thus, Ghosh et al. (2006) (163) showed that INF- γ stimulation resulted in the upregulation C/EBP β and its binding to the pro-collagen gene promoter, resulting in the disruption of collagen promoter activity.

Based on our results, we propose the following model whereby colon fibroblasts in the SCID mouse colitis model become activated and the effects this mesenchymal activation may have on the pathogenesis of inflammation (Fig. 6)

We hypothesise:

1) That T cells are activated in the draining lymph nodes to unknown Th1-inducing antigens through interaction with DC. These primed T cells then seed the colon where, in the presence of further antigen they become activated, expressing CD40L, but are prevented from apoptosing by interactions with local fibroblasts.

2) Under the influence of T cell IFN- γ , the local fibroblasts become activated and, in this state, interact with the CD40L⁺ T cells through membrane CD40. This signalling, in the presence of IFN- γ , upregulates the already high constitutive levels of IL-6 synthesised by the fibroblasts.

3) That IL-6 has an autocrine effect, further activating mesenchymal cells by different pathways, resulting in the production of C/EBP β :

- a) IL-6 signaling through STAT3/STAT3 homodimers results in mobilization of these homodimers into the nucleus, activating the upregulation of C/EBP β
- b) IL-6 signalling through Ras-Raf and MAP kinases results in the upregulation of C/EBP β
- c) Phosphorylation and activation of STAT1 by IL-6 will influence the IFN- γ signalling pathway, increasing upregulation of C/EBP β
- d) Using part of the IFN- γ signaling pathway, IL-6 signalling results in persistent phosphorylation of Jak2, which activates STAT1, allowing activation of MEKK1-ERK1/2 signaling pathways to upregulate transcription of C/EBP β .

4) That constant activation through phosphorylated Jak2 of MEKK1 results in phosphorylation of I κ B and degradation of I κ B, allowing NF κ B to enter the nucleus and bind to consensus sites in proinflammatory gene promoters.

5) That C/EBP β , phosphorylated by ERK1/2 through the IFN- γ signalling pathway, enters the nucleus and complexes with DNA-binding NF κ B, allowing transactivation of genes. Additional stimulation by IFN- γ and CD40L will allow fibroblasts to respond more vigorously in a synergistic manner, producing increased amounts of IL-6, CCL2, 3 and 5, all of which have been shown to be upregulated in IBD (9, 207-209).

6) That the production of CCL2, 3 and 5 will recruit immune cells, such as lymphocytes, monocytes, eosinophils and neutrophils (210) to the lesion and, together with the capacity of fibroblasts to prevent apoptosis of activated T cells in the lamina propria, will result in the chronic inflammatory responses seen in IBD (32, 211).

Our data aids in the understanding of the involvement of fibroblasts in the chronicity of inflammation and the hypothesis presented here points to further future studies in regard to IL-6 autocrine signaling and its effect on the activated phenotype of inflamed fibroblasts.

In conclusion, the results of this thesis suggest that mucosal fibroblasts in chronic inflammation respond to the surrounding milieu, become activated and transdifferentiate into a stable proinflammatory phenotype which may contribute to chronicity of the inflammation, and certainly influences its pathogenesis.

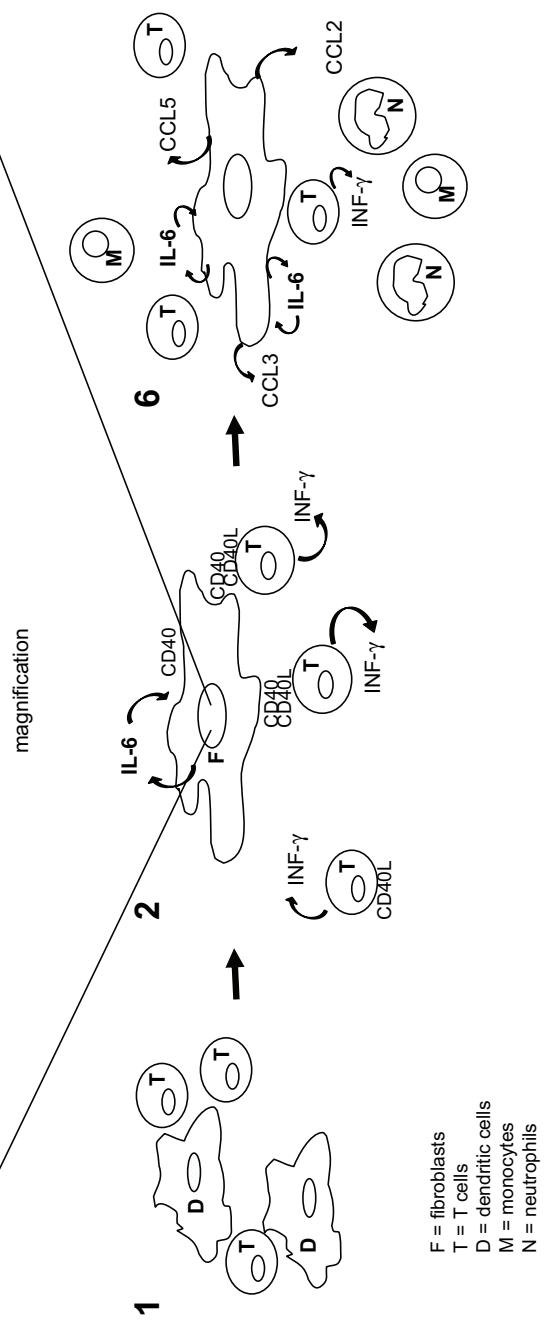
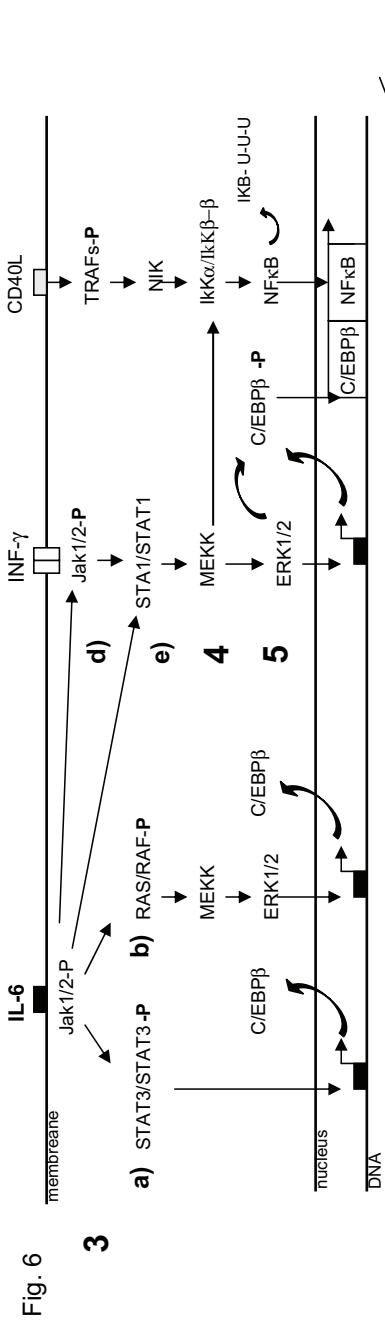

ACKNOWLEDGEMENTS

What a journey and without a doubt, a very interesting one!

Throughout this journey I have met a lot of people who I would like to thank. I have tired very hard not to forget anyone but please... don't forget the age factor ☺

First of all I like to thank **Paul Bland**, my supervisor. Thank you so much for your guidance, your knowledge, your teaching and your patients during all of these years and for reading my numerous revisions and correcting my English, I will never forget when you wrote in my manuscripts "rewrite this in English"☺

Nils Lycke, thank you for accepting me to be part of the former department of Clinical Immunology.

Carin, John, Linda, Juliana and Sandra. From the bottom of my heart

THANK YOU ♥♥♥

Without you I would not have finished this. Thank you for all your support, encouragement and most of all your company. Friday's "fika" will never be the same without you all. I'll miss you!

Krisitna, who would have thought that after studying together at Göteborgs Universitet we would end up working in the same department. As Mr. Spok would have said: most fascinating!
Tack min lilla kompis, min vän, min partner ☺ för all din stöd, tålmod och hjälp. Lycka till!

Miguel, muchacho! Gracias por tu amistad y tu ayuda durante estos anos. Y donde quiera que queden como post-docs en el mundo, tu y Mariam ya saben...de mi no se escapan! Mucha suerte en todo, se los desea a ambos de todo corazon, la huajira de mi.

Bettan I am extremely grateful to you because you always ask me how I was doing, especially during the rough moments, you showed that you care. Thanks for the talks and your good advice.

Mirjiana, hvala lijepa for your help during all my years as a PhD student. I enjoyed our talks a lot and thanks for your support.

Maria Ormestad thank you for all your help when I started here, back then I didn't even know the difference between a cell and a potato. Uhhmm, so... what is the difference?

Ellen my mate! Thank you for reading my work and your questions. I will always remember your thumb up during my pre-dissertation. It gave me confidence. Also, thank you for letting me spend Christmas in Newcastle with you and your family. I will never forget it.
Australia...It's a bloody long way...but I'll get there!

Linda Z, thank you for your company and support. I really missed our talks but you have to leave for a very good reason, your beautiful daughter Lova. Good luck with your work and patients, there is actually a light at the end of the tunnel.

Silvie, Thanks for coming on weekends to ask me to have lunch with you, it made long and hard weekends more bearable. I enjoyed our talks and we had good laughs. Remember, we are doing this “frivilligt”. Good luck with your work!

Anja, even after you were finished here you continued supporting and encouraging me. Thank you for everything and for answering my question regarding dissertation stuff.

Stina, you were always the first person I met in the mornings and I really appreciated the conversations we had around 7.00 o'clock. It was a good way to start the day. Thank also for your support and your help.

Anna and **Linda F.** Thank you for all your help and for being my connection with the rest of the lab. I don't know how many times I called and you helped me to find someone or something.

Martin I am going to miss our “guess what song this is” contest. But Martin you have to admit it, I was the best ☺. **Yu-Yuan** you are a really funny girl! I enjoyed your company enormously and I always had a good laugh working in the lab with you. You and Martin should have started long before. **Maria S** Sas epharisto poli for the good times in the lab. **Maria FF** thanks for spending time listening to me and your wise advice.

Peter and **Johan** “el duo dinamico” now you will have to look this up, this is so you don't forget your Spanish. I enjoyed having you as my students. Peter, thanks for spending time reading my manuscripts and asking me questions. I really appreciate it.

Britt-Marie, a huuge thanks to you for offering me your help when I was having rough times. I will never forget it. TACK! 🌹

Anneli, you are always happy, don't change girl. Thanks for always helping me to find things. It was great fun to have you as my work-out instructor; you are a very good one. **Ann-Marie**, I have a great writing room because of you. Thanks for the suggestion and all the nice talks. **Lena E** and **Karin**, thank you both for unswerving my silly questions and helping me with things in the lab.

Dubi, **Ullrika** and **Lena Ö**, thanks for asking how my things were going and your support. I really appreciate it.

Andrea, now you can relax! Molto grazie for your friendliness and your help during all this years with administrative question, especially these last months. Remember to take it easy!! **Viola**, thank you explaining to me the ordering of material system, sorry for all the mistakes I made.

Charlotte, meine sauerkraut und wurst esser freund. Vielen dank for all your support and funny and encouraging mails. Danke schön!! 🇩🇪. **Huamei** thanks for your support!

Francisco, de la distancia me has apollado y te has preocupado por mi. De todo **corazon**, GRACIAS!

My family, the biggest thank in the world to: especially my mother who is always supporting, worrying and caring for me. My broters; Yelko, Boris, Pedro and Cristian. My systers-in-law Luz-Maria and Madde (the best listener) and my godson/nephew Alexander, the most wonderful boy in the world. Thank you all for being there for me and your relentless support!

This work was supported by Vetenskapsrådet no. K2002-06X-14233, ALF grant 7351, Kungl och Hvitfeldtska Stiftelsen, Sahlgrenska Universitetsjukhuset stiftelse, Wilhem och Martina Lundgrens Vetenskapsfonder, Stiftelsen professor Nanna Svartz fond, Wellcome Trust Biomedical Research Collaboration Grant no. AL069896, Kungl. Vetenskaps- och Vitterhets-Samhälle i Göteborg and MIVAC, the Swedish Foundation for Strategic Research Mucosal Immunobiology & Vaccine Centre.

REFERENCES

1. **Fiocchi, C.** 2005. Inflammatory bowel disease pathogenesis: therapeutic implications. *Chin J Dig Dis* 6:6-9.
2. Järnrot, G. 1998. *Inflammatoriska tarmsjukdomar*. wyeth Lederle Nordiska AB
3. **Papadakis, K. A., and S. R. Targan.** 1999. Current theories on the causes of inflammatory bowel disease. *Gastroenterol Clin North Am* 28:283-296.
4. **Fiocchi, C.** 1998. Inflammatory bowel disease: etiology and pathogenesis. *Gastroenterology* 115:182-205.
5. **Braegger, C. P., and T. T. MacDonald.** 1994. Immune mechanisms in chronic inflammatory bowel disease. *Ann Allergy* 72:135-141.
6. **MacDonald, T. T., and S. Pettersson.** 2000. Bacterial regulation of intestinal immune responses. *Inflamm Bowel Dis* 6:116-122.
7. **Baggiolini, M.** 1998. Chemokines and leukocyte traffic. *Nature* 392:565-568.
8. **He, S. H.** 2004. Key role of mast cells and their major secretory products in inflammatory bowel disease. *World J Gastroenterol* 10:309-318.
9. **McCormack, G., D. Moriarty, D. P. O'Donoghue, P. A. McCormick, K. Sheahan, and A. W. Baird.** 2001. Tissue cytokine and chemokine expression in inflammatory bowel disease. *Inflamm Res* 50:491-495.
10. **Kunkel, E. J., D. J. Campbell, and E. C. Butcher.** 2003. Chemokines in lymphocyte trafficking and intestinal immunity. *Microcirculation* 10:313-323.
11. **Daig, R., T. Andus, E. Aschenbrenner, W. Falk, J. Scholmerich, and V. Gross.** 1996. Increased interleukin 8 expression in the colon mucosa of patients with inflammatory bowel disease. *Gut* 38:216-222.
12. **Grimm, M. C., S. K. Elsbury, P. Pavli, and W. F. Doe.** 1996. Enhanced expression and production of monocyte chemoattractant protein-1 in inflammatory bowel disease mucosa. *J Leukoc Biol* 59:804-812.
13. **Uguccioni, M., P. Gionchetti, D. F. Robbiani, F. Rizzello, S. Peruzzo, M. Campieri, and M. Baggiolini.** 1999. Increased expression of IP-10, IL-8, MCP-1, and MCP-3 in ulcerative colitis. *Am J Pathol* 155:331-336.
14. **MacDermott, R. P.** 1999. Chemokines in the inflammatory bowel diseases. *J Clin Immunol* 19:266-272.
15. **Papadakis, K. A., and S. R. Targan.** 2000. Role of cytokines in the pathogenesis of inflammatory bowel disease. *Annu Rev Med* 51:289-298.
16. **Kelsall, B. L., E. Stuber, M. Neurath, and W. Strober.** 1996. Interleukin-12 production by dendritic cells. The role of CD40-CD40L interactions in Th1 T-cell responses. *Ann N Y Acad Sci* 795:116-126.
17. **O'Garra, A., and K. Murphy.** 1994. Role of cytokines in determining T-lymphocyte function. *Curr Opin Immunol* 6:458-466.
18. **Niessner, M., and B. A. Volk.** 1995. Altered Th1/Th2 cytokine profiles in the intestinal mucosa of patients with inflammatory bowel disease as assessed by quantitative reversed transcribed polymerase chain reaction (RT-PCR). *Clin Exp Immunol* 101:428-435.
19. **Sawada-Hase, N., T. Kiyohara, J. Miyagawa, H. Ueyama, H. Nishibayashi, Y. Murayama, T. Kashihara, M. Nakahara, Y. Miyazaki, S. Kanayama, R. Nezu, Y.**

- Shinomura, and Y. Matsuzawa.** 2000. An increased number of CD40-high monocytes in patients with Crohn's disease. *Am J Gastroenterol* 95:1516-1523.
20. **Uhlig, H. H., B. S. McKenzie, S. Hue, C. Thompson, B. Joyce-Shaikh, R. Stepankova, N. Robinson, S. Buonocore, H. Tlaskalova-Hogenova, D. J. Cua, and F. Powrie.** 2006. Differential activity of IL-12 and IL-23 in mucosal and systemic innate immune pathology. *Immunity* 25:309-318.
 21. **Liu, Z., S. Colpaert, G. R. D'Haens, A. Kasran, M. de Boer, P. Rutgeerts, K. Geboes, and J. L. Ceuppens.** 1999. Hyperexpression of CD40 ligand (CD154) in inflammatory bowel disease and its contribution to pathogenic cytokine production. *J Immunol* 163:4049-4057.
 22. **Battaglia, E., L. Biancone, A. Resegotti, G. Emanuelli, G. R. Fronda, and G. Camussi.** 1999. Expression of CD40 and its ligand, CD40L, in intestinal lesions of Crohn's disease. *Am J Gastroenterol* 94:3279-3284.
 23. **Handel, M. L., L. B. McMorro, and E. M. Gravalles.** 1995. Nuclear factor-kappa B in rheumatoid synovium. Localization of p50 and p65. *Arthritis Rheum* 38:1762-1770.
 24. **Marok, R., P. G. Winyard, A. Coumbe, M. L. Kus, K. Gaffney, S. Blades, P. I. Mapp, C. J. Morris, D. R. Blake, C. Kaltschmidt, and P. A. Baeuerle.** 1996. Activation of the transcription factor nuclear factor-kappaB in human inflamed synovial tissue. *Arthritis Rheum* 39:583-591.
 25. **Rogler, G., C. M. Gelbmann, D. Vogl, M. Brunner, J. Scholmerich, W. Falk, T. Andus, and K. Brand.** 2001. Differential activation of cytokine secretion in primary human colonic fibroblast/myofibroblast cultures. *Scand J Gastroenterol* 36:389-398.
 26. **Rogler, G., K. Brand, D. Vogl, S. Page, R. Hofmeister, T. Andus, R. Knuechel, P. A. Baeuerle, J. Scholmerich, and V. Gross.** 1998. Nuclear factor kappaB is activated in macrophages and epithelial cells of inflamed intestinal mucosa. *Gastroenterology* 115:357-369.
 27. **Neurath, M. F., and S. Pettersson.** 1997. Predominant role of NF-kappa B p65 in the pathogenesis of chronic intestinal inflammation. *Immunobiology* 198:91-98.
 28. **Boirivant, M., M. Marini, G. Di Felice, A. M. Pronio, C. Montesani, R. Tersigni, and W. Strober.** 1999. Lamina propria T cells in Crohn's disease and other gastrointestinal inflammation show defective CD2 pathway-induced apoptosis. *Gastroenterology* 116:557-565.
 29. **Kabelitz, D., T. Pohl, and K. Pechhold.** 1993. Activation-induced cell death (apoptosis) of mature peripheral T lymphocytes. *Immunol Today* 14:338-339.
 30. **Ina, K., J. Itoh, K. Fukushima, K. Kusugami, T. Yamaguchi, K. Kyokane, A. Imada, D. G. Binion, A. Musso, G. A. West, G. M. Dobra, T. S. McCormick, E. G. Lapetina, A. D. Levine, C. A. Ottaway, and C. Fiocchi.** 1999. Resistance of Crohn's disease T cells to multiple apoptotic signals is associated with a Bcl-2/Bax mucosal imbalance. *J Immunol* 163:1081-1090.
 31. **Bu, P., A. Keshavarzian, D. D. Stone, J. Liu, P. T. Le, S. Fisher, and L. Qiao.** 2001. Apoptosis: one of the mechanisms that maintains unresponsiveness of the intestinal mucosal immune system. *J Immunol* 166:6399-6403.
 32. **Itoh, J., C. de La Motte, S. A. Strong, A. D. Levine, and C. Fiocchi.** 2001. Decreased Bax expression by mucosal T cells favours resistance to apoptosis in Crohn's disease. *Gut* 49:35-41.

33. **Eaden, J. A., K. R. Abrams, and J. F. Mayberry.** 2001. The risk of colorectal cancer in ulcerative colitis: a meta-analysis. *Gut* 48:526-535.
34. **Bansal, P., and A. Sonnenberg.** 1996. Risk factors of colorectal cancer in inflammatory bowel disease. *Am J Gastroenterol* 91:44-48.
35. **Hirano, T., S. Akira, T. Taga, and T. Kishimoto.** 1990. Biological and clinical aspects of interleukin 6. *Immunol Today* 11:443-449.
36. **Galizia, G., M. Orditura, C. Romano, E. Lieto, P. Castellano, L. Pelosio, V. Imperatore, G. Catalano, C. Pignatelli, and F. De Vita.** 2002. Prognostic significance of circulating IL-10 and IL-6 serum levels in colon cancer patients undergoing surgery. *Clin Immunol* 102:169-178.
37. **Chung, Y. C., and Y. F. Chang.** 2003. Serum interleukin-6 levels reflect the disease status of colorectal cancer. *J Surg Oncol* 83:222-226.
38. **Lekstrom-Himes, J., and K. G. Xanthopoulos.** 1998. Biological role of the CCAAT/enhancer-binding protein family of transcription factors. *J Biol Chem* 273:28545-28548.
39. **Ramji, D. P., and P. Foka.** 2002. CCAAT/enhancer-binding proteins: structure, function and regulation. *Biochem J* 365:561-575.
40. **Rask, K., M. Thorn, F. Ponten, W. Kraaz, K. Sundfeldt, L. Hedin, and S. Enerback.** 2000. Increased expression of the transcription factors CCAAT-enhancer binding protein-beta (C/EBB β) and C/EB ζ (CHOP) correlate with invasiveness of human colorectal cancer. *Int J Cancer* 86:337-343.
41. **Komuro, T.** 1990. Re-evaluation of fibroblasts and fibroblast-like cells. *Anat Embryol (Berl)* 182:103-112.
42. **Brittan, M., and N. A. Wright.** 2004. The gastrointestinal stem cell. *Cell Prolif* 37:35-53.
43. **Ogawa, M., A. C. LaRue, and C. J. Drake.** 2006. Hematopoietic origin of fibroblasts/myofibroblasts: Its pathophysiological implications. *Blood* 108:2893-2896.
44. **Powell, D. W., R. C. Mifflin, J. D. Valentich, S. E. Crowe, J. I. Saada, and A. B. West.** 1999. Myofibroblasts. I. Paracrine cells important in health and disease. *Am J Physiol* 277:C1-9.
45. **Maltseva, O., P. Folger, D. Zekaria, S. Petridou, and S. K. Masur.** 2001. Fibroblast growth factor reversal of the corneal myofibroblast phenotype. *Invest Ophthalmol Vis Sci* 42:2490-2495.
46. **Ramos, C., M. Montano, C. Becerril, J. Cisneros-Lira, L. Barrera, V. Ruiz, A. Pardo, and M. Selman.** 2006. Acidic fibroblast growth factor decreases alpha-smooth muscle actin expression and induces apoptosis in human normal lung fibroblasts. *Am J Physiol Lung Cell Mol Physiol* 291:L871-879.
47. **Kruglov, E. A., R. A. Nathanson, T. Nguyen, and J. A. Dranoff.** 2006. Secretion of MCP-1/CCL2 by bile duct epithelia induces myofibroblastic transdifferentiation of portal fibroblasts. *Am J Physiol Gastrointest Liver Physiol* 290:G765-771.
48. **Adegboyega, P. A., R. C. Mifflin, J. F. DiMari, J. I. Saada, and D. W. Powell.** 2002. Immunohistochemical study of myofibroblasts in normal colonic mucosa, hyperplastic polyps, and adenomatous colorectal polyps. *Arch Pathol Lab Med* 126:829-836.
49. **Alverts, B., Bray D, Lewis J, Raff M, Roberts K, Watson JD.** 1994. The molecular biology of the cell. third edition.

50. **Whiting, C. V., J. F. Tarlton, M. Bailey, C. L. Morgan, and P. W. Bland.** 2003. Abnormal mucosal extracellular matrix deposition is associated with increased TGF-beta receptor-expressing mesenchymal cells in a mouse model of colitis. *J Histochem Cytochem* 51:1177-1189.
51. **Kotaru, C., K. J. Schoonover, J. B. Trudeau, M. L. Huynh, X. Zhou, H. Hu, and S. E. Wenzel.** 2006. Regional fibroblast heterogeneity in the lung: implications for remodeling. *Am J Respir Crit Care Med* 173:1208-1215.
52. **Sempowski, G. D., S. Derdak, and R. P. Phipps.** 1996. Interleukin-4 and interferon-gamma discordantly regulate collagen biosynthesis by functionally distinct lung fibroblast subsets. *J Cell Physiol* 167:290-296.
53. **Derdak, S., D. P. Penney, P. Keng, M. E. Felch, D. Brown, and R. P. Phipps.** 1992. Differential collagen and fibronectin production by Thy 1+ and Thy 1- lung fibroblast subpopulations. *Am J Physiol* 263:L283-290.
54. **Okada, N., M. Kobayashi, K. Mugikura, Y. Okamatsu, S. Hanazawa, S. Kitano, and K. Hasegawa.** 1997. Interleukin-6 production in human fibroblasts derived from periodontal tissues is differentially regulated by cytokines and a glucocorticoid. *J Periodontal Res* 32:559-569.
55. **Verardi, S., R. C. Page, W. F. Ammons, and S. Bordin.** 2007. Differential chemokine response of fibroblast subtypes to complement C1q. *J Periodontal Res* 42:62-68.
56. **Brannigan, A. E., R. W. Watson, D. Beddy, H. Hurley, J. M. Fitzpatrick, and P. R. O'Connell.** 2002. Increased adhesion molecule expression in serosal fibroblasts isolated from patients with inflammatory bowel disease is secondary to inflammation. *Ann Surg* 235:507-511.
57. **Lee, W. S., M. K. Jain, B. M. Arkonac, D. Zhang, S. Y. Shaw, S. Kashiki, K. Maemura, S. L. Lee, N. K. Hollenberg, M. E. Lee, and E. Haber.** 1998. Thy-1, a novel marker for angiogenesis upregulated by inflammatory cytokines. *Circ Res* 82:845-851.
58. **Henniker, A.** 2001. CD90. *J Biol Regul Homeost Agents* 15:392-393.
59. **Saalbach, A., T. Wetzig, U. F. Haustein, and U. Anderegg.** 1999. Detection of human soluble Thy-1 in serum by ELISA. Fibroblasts and activated endothelial cells are a possible source of soluble Thy-1 in serum. *Cell Tissue Res* 298:307-315.
60. **Barker, T. H., H. E. Grenett, M. W. MacEwen, S. G. Tilden, G. M. Fuller, J. Settleman, A. Woods, J. Murphy-Ullrich, and J. S. Hagood.** 2004. Thy-1 regulates fibroblast focal adhesions, cytoskeletal organization and migration through modulation of p190 RhoGAP and Rho GTPase activity. *Exp Cell Res* 295:488-496.
61. **Koumas, L., and R. P. Phipps.** 2002. Differential COX localization and PG release in Thy-1(+) and Thy-1(-) human female reproductive tract fibroblasts. *Am J Physiol Cell Physiol* 283:C599-608.
62. **Hagood, J. S., P. J. Miller, J. A. Lasky, A. Tousson, B. Guo, G. M. Fuller, and J. C. McIntosh.** 1999. Differential expression of platelet-derived growth factor-alpha receptor by Thy-1(-) and Thy-1(+) lung fibroblasts. *Am J Physiol* 277:L218-224.
63. **Koumas, L., A. E. King, H. O. Critchley, R. W. Kelly, and R. P. Phipps.** 2001. Fibroblast heterogeneity: existence of functionally distinct Thy 1(+) and Thy 1(-) human female reproductive tract fibroblasts. *Am J Pathol* 159:925-935.

64. **Kon, K., and T. Fujiwara.** 1994. Transformation of fibroblasts into endothelial cells during angiogenesis. *Cell Tissue Res* 278:625-628.
65. **Hakelien, A. M., H. B. Landsverk, J. M. Robl, B. S. Skalhegg, and P. Collas.** 2002. Reprogramming fibroblasts to express T-cell functions using cell extracts. *Nat Biotechnol* 20:460-466.
66. **Goke, M., M. Kanai, and D. K. Podolsky.** 1998. Intestinal fibroblasts regulate intestinal epithelial cell proliferation via hepatocyte growth factor. *Am J Physiol* 274:G809-818.
67. **Lawrance, I. C., L. Maxwell, and W. Doe.** 2001. Altered response of intestinal mucosal fibroblasts to profibrogenic cytokines in inflammatory bowel disease. *Inflamm Bowel Dis* 7:226-236.
68. **Lund-Johansen, M., D. Scheie, T. Muller, T. Lundar, and E. Helseth.** 2001. Neurosurgical treatment of meningiomas in children and young adults. *Childs Nerv Syst* 17:719-723.
69. **Vogel, J. D., G. A. West, S. Danese, C. De La Motte, M. H. Phillips, S. A. Strong, J. Willis, and C. Fiocchi.** 2004. CD40-mediated immune-nonimmune cell interactions induce mucosal fibroblast chemokines leading to T-cell transmigration. *Gastroenterology* 126:63-80.
70. **Musso, A., T. P. Condon, G. A. West, C. De La Motte, S. A. Strong, A. D. Levine, C. F. Bennett, and C. Fiocchi.** 1999. Regulation of ICAM-1-mediated fibroblast-T cell reciprocal interaction: implications for modulation of gut inflammation. *Gastroenterology* 117:546-556.
71. **Chakravorty, D., and K. S. Kumar.** 1999. Interaction of lipopolysaccharide with human small intestinal lamina propria fibroblasts favors neutrophil migration and peripheral blood mononuclear cell adhesion by the production of proinflammatory mediators and adhesion molecules. *Biochim Biophys Acta* 1453:261-272.
72. **Ogura, N., M. Tobe, H. Sakamaki, H. Nagura, H. Hosaka, M. Akiba, Y. Abiko, and T. Kondoh.** 2004. Interleukin-1beta increases RANTES gene expression and production in synovial fibroblasts from human temporomandibular joint. *J Oral Pathol Med* 33:629-633.
73. **Yucel-Lindberg, T., and G. Brunius.** 2006. Epidermal growth factor synergistically enhances interleukin-8 production in human gingival fibroblasts stimulated with interleukin-1beta. *Arch Oral Biol* 51:892-898.
74. **Gordon, J. R.** 2000. TGFbeta1 and TNFalpha secreted by mast cells stimulated via the FcepsilonRI activate fibroblasts for high-level production of monocyte chemoattractant protein-1 (MCP-1). *Cell Immunol* 201:42-49.
75. **Pang, G., L. Couch, R. Batey, R. Clancy, and A. Cripps.** 1994. GM-CSF, IL-1 alpha, IL-1 beta, IL-6, IL-8, IL-10, ICAM-1 and VCAM-1 gene expression and cytokine production in human duodenal fibroblasts stimulated with lipopolysaccharide, IL-1 alpha and TNF-alpha. *Clin Exp Immunol* 96:437-443.
76. **Narayanan, P. K., K. E. LaRue, E. H. Goodwin, and B. E. Lehnert.** 1999. Alpha particles induce the production of interleukin-8 by human cells. *Radiat Res* 152:57-63.
77. **Yamamoto, T., B. Eckes, and T. Krieg.** 2001. High expression and autoinduction of monocyte chemoattractant protein-1 in scleroderma fibroblasts. *Eur J Immunol* 31:2936-2941.

78. **Lukacs, N. W., S. W. Chensue, R. E. Smith, R. M. Strieter, K. Warmington, C. Wilke, and S. L. Kunkel.** 1994. Production of monocyte chemoattractant protein-1 and macrophage inflammatory protein-1 alpha by inflammatory granuloma fibroblasts. *Am J Pathol* 144:711-718.
79. **Brouty-Boye, D., C. Pottin-Clemenceau, C. Doucet, C. Jasmin, and B. Azzarone.** 2000. Chemokines and CD40 expression in human fibroblasts. *Eur J Immunol* 30:914-919.
80. **Proost, P., A. K. Vynckier, F. Mahieu, W. Put, B. Grillet, S. Struyf, A. Wuyts, G. Opdenakker, and J. Van Damme.** 2003. Microbial Toll-like receptor ligands differentially regulate CXCL10/IP-10 expression in fibroblasts and mononuclear leukocytes in synergy with IFN-gamma and provide a mechanism for enhanced synovial chemokine levels in septic arthritis. *Eur J Immunol* 33:3146-3153.
81. **Kontoyiannis, D., M. Pasparakis, T. T. Pizarro, F. Cominelli, and G. Kollias.** 1999. Impaired on/off regulation of TNF biosynthesis in mice lacking TNF AU-rich elements: implications for joint and gut-associated immunopathologies. *Immunity* 10:387-398.
82. **Ingram, J. L., A. B. Rice, K. Geisenhoffer, D. K. Madtes, and J. C. Bonner.** 2004. IL-13 and IL-1beta promote lung fibroblast growth through coordinated up-regulation of PDGF-AA and PDGF-Ralpha. *Faseb J* 18:1132-1134.
83. **Raap, T., H. P. Justen, L. E. Miller, M. Cutolo, J. Scholmerich, and R. H. Straub.** 2000. Neurotransmitter modulation of interleukin 6 (IL-6) and IL-8 secretion of synovial fibroblasts in patients with rheumatoid arthritis compared to osteoarthritis. *J Rheumatol* 27:2558-2565.
84. **Fireman, E., S. Kivity, I. Shahar, T. Reshef, and Y. A. Mekori.** 1999. Secretion of stem cell factor by alveolar fibroblasts in interstitial lung diseases. *Immunol Lett* 67:229-236.
85. **Takashiba, S., M. Takigawa, K. Takahashi, F. Myokai, F. Nishimura, T. Chihara, H. Kurihara, Y. Nomura, and Y. Murayama.** 1992. Interleukin-8 is a major neutrophil chemotactic factor derived from cultured human gingival fibroblasts stimulated with interleukin-1 beta or tumor necrosis factor alpha. *Infect Immun* 60:5253-5258.
86. **Sullivan, D. E., M. Ferris, D. Pociask, and A. R. Brody.** 2005. Tumor necrosis factor-alpha induces transforming growth factor-beta1 expression in lung fibroblasts through the extracellular signal-regulated kinase pathway. *Am J Respir Cell Mol Biol* 32:342-349.
87. **Serpier, H., P. Gillery, V. Salmon-Ehr, R. Garnotel, N. Georges, B. Kalis, and F. X. Maquart.** 1997. Antagonistic effects of interferon-gamma and interleukin-4 on fibroblast cultures. *J Invest Dermatol* 109:158-162.
88. **Villagomez, M. T., S. J. Bae, I. Ogawa, M. Takenaka, and I. Katayama.** 2004. Tumour necrosis factor-alpha but not interferon-gamma is the main inducer of inducible protein-10 in skin fibroblasts from patients with atopic dermatitis. *Br J Dermatol* 150:910-916.
89. **Marchand-Adam, S., L. Plantier, D. Bernuau, A. Legrand, M. Cohen, J. Marchal, P. Soler, G. Leseche, H. Mal, M. Aubier, M. Dehoux, and B. Crestani.** 2005. Keratinocyte growth factor expression by fibroblasts in pulmonary fibrosis: poor response to interleukin-1beta. *Am J Respir Cell Mol Biol* 32:470-477.

90. **Fries, K. M., M. E. Felch, and R. P. Phipps.** 1994. Interleukin-6 is an autocrine growth factor for murine lung fibroblast subsets. *Am J Respir Cell Mol Biol* 11:552-560.
91. **Lawrence, A., D. Khanna, R. Misra, and A. Aggarwal.** 2006. Increased expression of basic fibroblast growth factor in skin of patients with systemic sclerosis. *Dermatol Online J* 12:2.
92. **Karasuyama, H., and F. Melchers.** 1988. Establishment of mouse cell lines which constitutively secrete large quantities of interleukin 2, 3, 4 or 5, using modified cDNA expression vectors. *Eur J Immunol* 18:97-104.
93. **Valentinis, B., A. Morrione, F. Peruzzi, M. Prisco, K. Reiss, and R. Baserga.** 1999. Anti-apoptotic signaling of the IGF-I receptor in fibroblasts following loss of matrix adhesion. *Oncogene* 18:1827-1836.
94. **Carulli, M. T., V. H. Ong, M. Ponticos, X. Shiwen, D. J. Abraham, C. M. Black, and C. P. Denton.** 2005. Chemokine receptor CCR2 expression by systemic sclerosis fibroblasts: evidence for autocrine regulation of myofibroblast differentiation. *Arthritis Rheum* 52:3772-3782.
95. **Salmon, M., D. Scheel-Toellner, A. P. Huissoon, D. Pilling, N. Shamsadeen, H. Hyde, A. D. D'Angeac, P. A. Bacon, P. Emery, and A. N. Akbar.** 1997. Inhibition of T cell apoptosis in the rheumatoid synovium. *J Clin Invest* 99:439-446.
96. **Gombert, W., N. J. Borthwick, D. L. Wallace, H. Hyde, M. Bofill, D. Pilling, P. C. Beverley, G. Janossy, M. Salmon, and A. N. Akbar.** 1996. Fibroblasts prevent apoptosis of IL-2-deprived T cells without inducing proliferation: a selective effect on Bcl-XL expression. *Immunology* 89:397-404.
97. **Scott, S., F. Pandolfi, and J. T. Kurnick.** 1990. Fibroblasts mediate T cell survival: a proposed mechanism for retention of primed T cells. *J Exp Med* 172:1873-1876.
98. **Geiler, T., J. Kriegsmann, G. M. Keyszer, R. E. Gay, and S. Gay.** 1994. A new model for rheumatoid arthritis generated by engraftment of rheumatoid synovial tissue and normal human cartilage into SCID mice. *Arthritis Rheum* 37:1664-1671.
99. **Takayanagi, H., T. Juji, T. Miyazaki, H. Iizuka, T. Takahashi, M. Isshiki, M. Okada, Y. Tanaka, Y. Koshihara, H. Oda, T. Kurokawa, K. Nakamura, and S. Tanaka.** 1999. Suppression of arthritic bone destruction by adenovirus-mediated csk gene transfer to synoviocytes and osteoclasts. *J Clin Invest* 104:137-146.
100. **Atreya, R., and M. F. Neurath.** 2005. Involvement of IL-6 in the pathogenesis of inflammatory bowel disease and colon cancer. *Clin Rev Allergy Immunol* 28:187-196.
101. **Schreiber, S., S. Nikolaus, and J. Hampe.** 1998. Activation of nuclear factor kappa B in inflammatory bowel disease. *Gut* 42:477-484.
102. **Makarov, S. S., W. N. Johnston, J. C. Olsen, J. M. Watson, K. Mondal, C. Rinehart, and J. S. Haskill.** 1997. NF-kappa B as a target for anti-inflammatory gene therapy: suppression of inflammatory responses in monocytic and stromal cells by stable gene transfer of I kappa B alpha cDNA. *Gene Ther* 4:846-852.
103. **Aupperle, K. R., D. L. Boyle, M. Hendrix, E. A. Sefror, N. J. Zvaifler, M. Barbosa, and G. S. Firestein.** 1998. Regulation of synoviocyte proliferation, apoptosis, and invasion by the p53 tumor suppressor gene. *Am J Pathol* 152:1091-1098.
104. **Smith, R. S., T. J. Smith, T. M. Blieden, and R. P. Phipps.** 1997. Fibroblasts as sentinel cells. Synthesis of chemokines and regulation of inflammation. *Am J Pathol* 151:317-322.

105. **Buckley, C. D., D. Pilling, J. M. Lord, A. N. Akbar, D. Scheel-Toellner, and M. Salmon.** 2001. Fibroblasts regulate the switch from acute resolving to chronic persistent inflammation. *Trends Immunol* 22:199-204.
106. **Lo, D., L. Feng, L. Li, M. J. Carson, M. Crowley, M. Pauza, A. Nguyen, and C. R. Reilly.** 1999. Integrating innate and adaptive immunity in the whole animal. *Immunol Rev* 169:225-239.
107. **Xia, Y., M. E. Pauza, L. Feng, and D. Lo.** 1997. RelB regulation of chemokine expression modulates local inflammation. *Am J Pathol* 151:375-387.
108. **van Kooten, C., and J. Banchereau.** 1997. Functional role of CD40 and its ligand. *Int Arch Allergy Immunol* 113:393-399.
109. **King, A. E., R. W. Kelly, H. O. Critchley, A. Malmstrom, M. Sennstrom, and R. P. Phipps.** 2001. Cd40 expression in uterine tissues: a key regulator of cytokine expression by fibroblasts. *J Clin Endocrinol Metab* 86:405-412.
110. **Rissoan, M. C., C. Van Kooten, P. Chomarat, L. Galibert, I. Durand, F. Thivolet-Bejui, P. Miossec, and J. Banchereau.** 1996. The functional CD40 antigen of fibroblasts may contribute to the proliferation of rheumatoid synovium. *Clin Exp Immunol* 106:481-490.
111. **Sugiura, T., Y. Kawaguchi, M. Harigai, K. Takagi, S. Ohta, C. Fukasawa, M. Hara, and N. Kamatani.** 2000. Increased CD40 expression on muscle cells of polymyositis and dermatomyositis: role of CD40-CD40 ligand interaction in IL-6, IL-8, IL-15, and monocyte chemoattractant protein-1 production. *J Immunol* 164:6593-6600.
112. **Dongari-Bagtzoglou, A. I., W. D. Warren, M. T. Berton, and J. L. Ebersole.** 1997. CD40 expression by gingival fibroblasts: correlation of phenotype with function. *Int Immunol* 9:1233-1241.
113. **Fries, K. M., G. D. Sempowski, A. A. Gaspari, T. Blieden, R. J. Looney, and R. P. Phipps.** 1995. CD40 expression by human fibroblasts. *Clin Immunol Immunopathol* 77:42-51.
114. **Sempowski, G. D., J. Rozenblit, T. J. Smith, and R. P. Phipps.** 1998. Human orbital fibroblasts are activated through CD40 to induce proinflammatory cytokine production. *Am J Physiol* 274:C707-714.
115. **Zhang, Y., H. J. Cao, B. Graf, H. Meekins, T. J. Smith, and R. P. Phipps.** 1998. CD40 engagement up-regulates cyclooxygenase-2 expression and prostaglandin E2 production in human lung fibroblasts. *J Immunol* 160:1053-1057.
116. **Cao, H. J., H. S. Wang, Y. Zhang, H. Y. Lin, R. P. Phipps, and T. J. Smith.** 1998. Activation of human orbital fibroblasts through CD40 engagement results in a dramatic induction of hyaluronan synthesis and prostaglandin endoperoxide H synthase-2 expression. Insights into potential pathogenic mechanisms of thyroid-associated ophthalmopathy. *J Biol Chem* 273:29615-29625.
117. **Gelbmann, C. M., S. N. Leeb, D. Vogl, M. Maendel, H. Herfarth, J. Scholmerich, W. Falk, and G. Rogler.** 2003. Inducible CD40 expression mediates NFkappaB activation and cytokine secretion in human colonic fibroblasts. *Gut* 52:1448-1456.
118. **Paulie, S., B. Ehlin-Henriksson, H. Mellstedt, H. Koho, H. Ben-Aissa, and P. Perlmann.** 1985. A p50 surface antigen restricted to human urinary bladder carcinomas and B lymphocytes. *Cancer Immunol Immunother* 20:23-28.
119. **Kehry, M. R.** 1996. CD40-mediated signaling in B cells. Balancing cell survival, growth, and death. *J Immunol* 156:2345-2348.

120. **van Kooten, C., and J. Banchereau.** 1997. Functions of CD40 on B cells, dendritic cells and other cells. *Curr Opin Immunol* 9:330-337.
121. **Berberich, i.** 1994. Cross-linking CD40 on B cells rapidly activates Nuclear Factor-kB. *The journal of immunology* 153.
122. **Henz, B. M., M. Maurer, U. Lippert, M. Worm, and M. Babina.** 2001. Mast cells as initiators of immunity and host defense. *Exp Dermatol* 10:1-10.
123. **Gauchat, J. F., S. Henchoz, G. Mazzei, J. P. Aubry, T. Brunner, H. Blasey, P. Life, D. Talabot, L. Flores-Romo, J. Thompson, and et al.** 1993. Induction of human IgE synthesis in B cells by mast cells and basophils. *Nature* 365:340-343.
124. **Gauchat, J. F., S. Henchoz, D. Fattah, G. Mazzei, J. P. Aubry, T. Jomotte, L. Dash, K. Page, R. Solari, D. Aldebert, and et al.** 1995. CD40 ligand is functionally expressed on human eosinophils. *Eur J Immunol* 25:863-865.
125. **van Kooten, C., and J. Banchereau.** 2000. CD40-CD40 ligand. *J Leukoc Biol* 67:2-17.
126. **Vogel, L. A., and R. J. Noelle.** 1998. CD40 and its crucial role as a member of the TNFR family. *Semin Immunol* 10:435-442.
127. **Yellin, M. J., J. Brett, D. Baum, A. Matsushima, M. Szabolcs, D. Stern, and L. Chess.** 1995. Functional interactions of T cells with endothelial cells: the role of CD40L-CD40-mediated signals. *J Exp Med* 182:1857-1864.
128. **Schonbeck, U., and P. Libby.** 2001. The CD40/CD154 receptor/ligand dyad. *Cell Mol Life Sci* 58:4-43.
129. **Baeuerle, P. A., and D. Baltimore.** 1996. NF-kappa B: ten years after. *Cell* 87:13-20.
130. **Ghosh, S., M. J. May, and E. B. Kopp.** 1998. NF-kappa B and Rel proteins: evolutionarily conserved mediators of immune responses. *Annu Rev Immunol* 16:225-260.
131. **Hsing, Y., B. S. Hostager, and G. A. Bishop.** 1997. Characterization of CD40 signaling determinants regulating nuclear factor-kappa B activation in B lymphocytes. *J Immunol* 159:4898-4906.
132. **Tripathi, P.** 2006. NF-kB transcription factor: a key player in the generation o f immune responses. *Current Science* 90.
133. **Cho, C. S., M. L. Cho, S. Y. Min, W. U. Kim, D. J. Min, S. S. Lee, S. H. Park, J. Choe, and H. Y. Kim.** 2000. CD40 engagement on synovial fibroblast up-regulates production of vascular endothelial growth factor. *J Immunol* 164:5055-5061.
134. **Yellin, M. J., S. Winikoff, S. M. Fortune, D. Baum, M. K. Crow, S. Lederman, and L. Chess.** 1995. Ligation of CD40 on fibroblasts induces CD54 (ICAM-1) and CD106 (VCAM-1) up-regulation and IL-6 production and proliferation. *J Leukoc Biol* 58:209-216.
135. **Beg, A. A., and D. Baltimore.** 1996. An essential role for NF-kappaB in preventing TNF-alpha-induced cell death. *Science* 274:782-784.
136. **Imada, K., and W. J. Leonard.** 2000. The Jak-STAT pathway. *Mol Immunol* 37:1-11.
137. **Weihua, X., V. Kolla, and D. V. Kalvakolanu.** 1997. Interferon gamma-induced transcription of the murine ISGF3gamma (p48) gene is mediated by novel factors. *Proc Natl Acad Sci U S A* 94:103-108.
138. **Roy, S. K., S. J. Wachira, X. Weihua, J. Hu, and D. V. Kalvakolanu.** 2000. CCAAT/enhancer-binding protein-beta regulates interferon-induced transcription through a novel element

J Biol Chem 275:12626-12632.

139. **Metz, R., and E. Ziff.** 1991. cAMP stimulates the C/EBP-related transcription factor rNFIL-6 to trans-locate to the nucleus and induce c-fos transcription. *Genes Dev* 5:1754-1766.
140. **Xiao, W., D. R. Hodge, L. Wang, X. Yang, X. Zhang, and W. L. Farrar.** 2004. Co-operative functions between nuclear factors NFkappaB and CCAT/enhancer-binding protein-beta (C/EBP-beta) regulate the IL-6 promoter in autocrine human prostate cancer cells. *Prostate* 61:354-370.
141. **LeClair, K. P., M. A. Blonar, and P. A. Sharp.** 1992. The p50 subunit of NF-kappa B associates with the NF-IL6 transcription factor. *Proc Natl Acad Sci U S A* 89:8145-8149.
142. **Betts, J. C., J. K. Cheshire, S. Akira, T. Kishimoto, and P. Woo.** 1993. The role of NF-kappa B and NF-IL6 transactivating factors in the synergistic activation of human serum amyloid A gene expression by interleukin-1 and interleukin-6. *J Biol Chem* 268:25624-25631.
143. **Hirano, T., K. Yasukawa, H. Harada, T. Taga, Y. Watanabe, T. Matsuda, S. Kashiwamura, K. Nakajima, K. Koyama, A. Iwamatsu, and et al.** 1986. Complementary DNA for a novel human interleukin (BSF-2) that induces B lymphocytes to produce immunoglobulin. *Nature* 324:73-76.
144. **Kishimoto, T., S. Akira, M. Narazaki, and T. Taga.** 1995. Interleukin-6 family of cytokines and gp130. *Blood* 86:1243-1254.
145. **Tsukamoto, T., Y. Kumamoto, N. Miyao, N. Masumori, A. Takahashi, and M. Yanase.** 1992. Interleukin-6 in renal cell carcinoma. *J Urol* 148:1778-1781; discussion 1781-1772.
146. **Jones, S. A., S. Horiuchi, N. Topley, N. Yamamoto, and G. M. Fuller.** 2001. The soluble interleukin 6 receptor: mechanisms of production and implications in disease. *Faseb J* 15:43-58.
147. **Ogata, A., D. Chauhan, G. Teoh, S. P. Treon, M. Urashima, R. L. Schlossman, and K. C. Anderson.** 1997. IL-6 triggers cell growth via the Ras-dependent mitogen-activated protein kinase cascade. *J Immunol* 159:2212-2221.
148. **Nakajima, T., S. Kinoshita, T. Sasagawa, K. Sasaki, M. Naruto, T. Kishimoto, and S. Akira.** 1993. Phosphorylation at threonine-235 by a ras-dependent mitogen-activated protein kinase cascade is essential for transcription factor NF-IL6. *Proc Natl Acad Sci U S A* 90:2207-2211.
149. **Kumar, G., S. Gupta, S. Wang, and A. E. Nel.** 1994. Involvement of Janus kinases, p52shc, Raf-1, and MEK-1 in the IL-6-induced mitogen-activated protein kinase cascade of a growth-responsive B cell line. *J Immunol* 153:4436-4447.
150. **Xia, C., J. K. Cheshire, H. Patel, and P. Woo.** 1997. Cross-talk between transcription factors NF-kappa B and C/EBP in the transcriptional regulation of genes. *Int J Biochem Cell Biol* 29:1525-1539.
151. **Lou, W., Z. Ni, K. Dyer, D. J. Tweardy, and A. C. Gao.** 2000. Interleukin-6 induces prostate cancer cell growth accompanied by activation of stat3 signaling pathway. *Prostate* 42:239-242.
152. **Nishimoto, N., T. Kishimoto, and K. Yoshizaki.** 2000. Anti-interleukin 6 receptor antibody treatment in rheumatic disease. *Ann Rheum Dis* 59 Suppl 1:i21-27.

153. **Ghosh, A. K., W. Yuan, Y. Mori, S. Chen, and J. Varga.** 2001. Antagonistic regulation of type I collagen gene expression by interferon-gamma and transforming growth factor-beta. Integration at the level of p300/CBP transcriptional coactivators. *J Biol Chem* 276:11041-11048.
154. **Yuan, W., T. Yufit, L. Li, Y. Mori, S. J. Chen, and J. Varga.** 1999. Negative modulation of alpha1(I) procollagen gene expression in human skin fibroblasts: transcriptional inhibition by interferon-gamma. *J Cell Physiol* 179:97-108.
155. **Narayanan, A. S., R. C. Page, and J. Swanson.** 1989. Collagen synthesis by human fibroblasts. Regulation by transforming growth factor-beta in the presence of other inflammatory mediators. *Biochem J* 260:463-469.
156. **Li, M. O., Y. Y. Wan, S. Sanjabi, A. K. Robertson, and R. A. Flavell.** 2006. Transforming growth factor-beta regulation of immune responses. *Annu Rev Immunol* 24:99-146.
157. **Lopez-Casillas, F., J. L. Wrana, and J. Massague.** 1993. Betaglycan presents ligand to the TGF beta signaling receptor. *Cell* 73:1435-1444.
158. **St-Jacques, S., U. Cymerman, N. Pece, and M. Letarte.** 1994. Molecular characterization and in situ localization of murine endoglin reveal that it is a transforming growth factor-beta binding protein of endothelial and stromal cells. *Endocrinology* 134:2645-2657.
159. **Liu, Q., S. S. Huang, and J. S. Huang.** 1997. Function of the type V transforming growth factor beta receptor in transforming growth factor beta-induced growth inhibition of mink lung epithelial cells. *J Biol Chem* 272:18891-18895.
160. **Schiller, M., D. Javelaud, and A. Mauviel.** 2004. TGF-beta-induced SMAD signaling and gene regulation: consequences for extracellular matrix remodeling and wound healing. *J Dermatol Sci* 35:83-92.
161. **Fiocchi, C.** 2001. TGF-beta/Smad signaling defects in inflammatory bowel disease: mechanisms and possible novel therapies for chronic inflammation. *J Clin Invest* 108:523-526.
162. **Weng, H., P. R. Mertens, A. M. Gressner, and S. Dooley.** 2007. IFN-gamma abrogates profibrogenic TGF-beta signaling in liver by targeting expression of inhibitory and receptor Smads. *J Hepatol* 46:295-303.
163. **Ghosh, A. K., S. Bhattacharyya, Y. Mori, and J. Varga.** 2006. Inhibition of collagen gene expression by interferon-gamma: novel role of the CCAAT/enhancer binding protein beta (C/EBPbeta). *J Cell Physiol* 207:251-260.
164. **Hu, J., S. K. Roy, P. S. Shapiro, S. R. Rodig, S. P. Reddy, L. C. Platanius, R. D. Schreiber, and D. V. Kalvakolanu.** 2001. ERK1 and ERK2 activate CCAAT/enhancer-binding protein-beta-dependent gene transcription in response to interferon-gamma. *J Biol Chem* 276:287-297.
165. **Kruidenier, L., and H. W. Verspaget.** 2002. Review article: oxidative stress as a pathogenic factor in inflammatory bowel disease--radicals or ridiculous? *Aliment Pharmacol Ther* 16:1997-2015.
166. **Stallmach, A., D. Schuppan, H. H. Riese, H. Matthes, and E. O. Riecken.** 1992. Increased collagen type III synthesis by fibroblasts isolated from strictures of patients with Crohn's disease. *Gastroenterology* 102:1920-1929.
167. **Rieder, F., J. Brenmoehl, S. Leeb, J. Scholmerich, and G. Rogler.** 2007. Wound healing and fibrosis in intestinal disease. *Gut* 56:130-139.

168. **Blobe, G. C., W. P. Schiemann, and H. F. Lodish.** 2000. Role of transforming growth factor beta in human disease. *N Engl J Med* 342:1350-1358.
169. **Wells, R. G.** 2000. Fibrogenesis. V. TGF-beta signaling pathways. *Am J Physiol Gastrointest Liver Physiol* 279:G845-850.
170. **Jurjus, A. R., N. N. Khoury, and J. M. Reimund.** 2004. Animal models of inflammatory bowel disease. *J Pharmacol Toxicol Methods* 50:81-92.
171. **Morrissey, P. J., K. Charrier, S. Braddy, D. Liggitt, and J. D. Watson.** 1993. CD4+ T cells that express high levels of CD45RB induce wasting disease when transferred into congenic severe combined immunodeficient mice. Disease development is prevented by cotransfer of purified CD4+ T cells *J Exp Med* 178:237-244.
172. **Powrie, F., M. W. Leach, S. Mauze, L. B. Caddle, and R. L. Coffman.** 1993. Phenotypically distinct subsets of CD4+ T cells induce or protect from chronic intestinal inflammation in C. B-17 scid mice. *Int Immunol* 5:1461-1471.
173. **Neurath, M. F., I. Fuss, B. L. Kelsall, E. Stuber, and W. Strober.** 1995. Antibodies to interleukin 12 abrogate established experimental colitis in mice. *J Exp Med* 182:1281-1290.
174. **Okayasu, I., S. Hatakeyama, M. Yamada, T. Ohkusa, Y. Inagaki, and R. Nakaya.** 1990. A novel method in the induction of reliable experimental acute and chronic ulcerative colitis in mice. *Gastroenterology* 98:694-702.
175. **Boirivant, M., I. J. Fuss, A. Chu, and W. Strober.** 1998. Oxazolone colitis: A murine model of T helper cell type 2 colitis treatable with antibodies to interleukin 4. *J Exp Med* 188:1929-1939.
176. **Hollander, G. A., S. J. Simpson, E. Mizoguchi, A. Nichogiannopoulou, J. She, J. C. Gutierrez-Ramos, A. K. Bhan, S. J. Burakoff, B. Wang, and C. Terhorst.** 1995. Severe colitis in mice with aberrant thymic selection. *Immunity* 3:27-38.
177. **Kuhn, R., J. Lohler, D. Rennick, K. Rajewsky, and W. Muller.** 1993. Interleukin-10-deficient mice develop chronic enterocolitis. *Cell* 75:263-274.
178. **Rudolph, U., M. J. Finegold, S. S. Rich, G. R. Harriman, Y. Srinivasan, P. Brabet, A. Bradley, and L. Birnbaumer.** 1995. Gi2 alpha protein deficiency: a model of inflammatory bowel disease. *J Clin Immunol* 15:101S-105S.
179. **Cong, Y., S. L. Brandwein, R. P. McCabe, A. Lazenby, E. H. Birkenmeier, J. P. Sundberg, and C. O. Elson.** 1998. CD4+ T cells reactive to enteric bacterial antigens in spontaneously colitic C3H/HeJBir mice: increased T helper cell type 1 response and ability to transfer disease. *J Exp Med* 187:855-864.
180. **Matsumoto, S., Y. Okabe, H. Setoyama, K. Takayama, J. Ohtsuka, H. Funahashi, A. Imaoka, Y. Okada, and Y. Umesaki.** 1998. Inflammatory bowel disease-like enteritis and caecitis in a senescence accelerated mouse P1/Yit strain. *Gut* 43:71-78.
181. **Watanabe, M., Y. Ueno, T. Yajima, S. Okamoto, T. Hayashi, M. Yamazaki, Y. Iwao, H. Ishii, S. Habu, M. Uehira, H. Nishimoto, H. Ishikawa, J. Hata, and T. Hibi.** 1998. Interleukin 7 transgenic mice develop chronic colitis with decreased interleukin 7 protein accumulation in the colonic mucosa. *J Exp Med* 187:389-402.
182. **Wirtz, S., S. Finotto, S. Kanzler, A. W. Lohse, M. Blessing, H. A. Lehr, P. R. Galle, and M. F. Neurath.** 1999. Cutting edge: chronic intestinal inflammation in STAT-4 transgenic mice: characterization of disease and adoptive transfer by TNF- plus IFN-

- gamma-producing CD4⁺ T cells that respond to bacterial antigens. *J Immunol* 162:1884-1888.
183. **Greenbaum, L. E., W. Li, D. E. Cressman, Y. Peng, G. Ciliberto, V. Poli, and R. Taub.** 1998. CCAAT enhancer-binding protein beta is required for normal hepatocyte proliferation in mice after partial hepatectomy. *J Clin Invest* 102:996-1007.
 184. **Takiguchi, M.** 1998. The C/EBP family of transcription factors in the liver and other organs. *Int J Exp Pathol* 79:369-391.
 185. **Tau, G., and P. Rothman.** 1999. Biologic functions of the IFN-gamma receptors. *Allergy* 54:1233-1251.
 186. **Chae, H. J., J. O. Byun, S. W. Chae, H. M. Kim, H. I. Choi, H. O. Pae, H. T. Chung, and H. R. Kim.** 2005. p38 MAPK and NF-kappaB on IL-6 release in human gingival fibroblasts. *Immunopharmacol Immunotoxicol* 27:631-646.
 187. **Lee, A. H., J. H. Hong, and Y. S. Seo.** 2000. Tumour necrosis factor-alpha and interferon-gamma synergistically activate the RANTES promoter through nuclear factor kappaB and interferon regulatory factor 1 (IRF-1) transcription factors. *Biochem J* 350 Pt 1:131-138.
 188. **Genin, P., M. Algarte, P. Roof, R. Lin, and J. Hiscott.** 2000. Regulation of RANTES chemokine gene expression requires cooperativity between NF-kappa B and IFN-regulatory factor transcription factors. *J Immunol* 164:5352-5361.
 189. **Filer, A., G. Parsonage, E. Smith, C. Osborne, A. M. Thomas, S. J. Curnow, G. E. Rainger, K. Raza, G. B. Nash, J. Lord, M. Salmon, and C. D. Buckley.** 2006. Differential survival of leukocyte subsets mediated by synovial, bone marrow, and skin fibroblasts: site-specific versus activation-dependent survival of T cells and neutrophils. *Arthritis Rheum* 54:2096-2108.
 190. **Becker, J. M.** 1999. Surgical therapy for ulcerative colitis and Crohn's disease. *Gastroenterol Clin North Am* 28:371-390, viii-ix.
 191. **Tarlton, J. F., C. V. Whiting, D. Tunmore, S. Bregenholt, J. Reimann, M. H. Claesson, and P. W. Bland.** 2000. The role of up-regulated serine proteases and matrix metalloproteinases in the pathogenesis of a murine model of colitis. *Am J Pathol* 157:1927-1935.
 192. **Kim, E. C., Y. Zhu, V. Andersen, D. Sciaky, H. J. Cao, H. Meekins, T. J. Smith, and P. Lance.** 1998. Cytokine-mediated PGE2 expression in human colonic fibroblasts. *Am J Physiol* 275:C988-994.
 193. **Danese, S., M. Sans, and C. Fiocchi.** 2004. The CD40/CD40L costimulatory pathway in inflammatory bowel disease. *Gut* 53:1035-1043.
 194. **Polese, L., I. Angriman, A. Cecchetto, L. Norberto, M. Scarpa, C. Ruffolo, M. Barollo, A. Sommariva, and D. F. D'Amico.** 2002. The role of CD40 in ulcerative colitis: histochemical analysis and clinical correlation. *Eur J Gastroenterol Hepatol* 14:237-241.
 195. **Vuckovic, S., T. H. Florin, D. Khalil, M. F. Zhang, K. Patel, I. Hamilton, and D. N. Hart.** 2001. CD40 and CD86 upregulation with divergent CMRF44 expression on blood dendritic cells in inflammatory bowel diseases. *Am J Gastroenterol* 96:2946-2956.
 196. **Cavarretta, I. T., H. Neuwirt, G. Untergasser, P. L. Moser, M. H. Zaki, H. Steiner, H. Rumpold, D. Fuchs, A. Hobisch, J. A. Nemeth, and Z. Culig.** 2006. The

- antiapoptotic effect of IL-6 autocrine loop in a cellular model of advanced prostate cancer is mediated by Mcl-1. *Oncogene*.
197. **Schuringa, J. J., A. T. Wierenga, W. Kruijer, and E. Vellenga.** 2000. Constitutive Stat3, Tyr705, and Ser727 phosphorylation in acute myeloid leukemia cells caused by the autocrine secretion of interleukin-6. *Blood* 95:3765-3770.
 198. **Lee, F. S., R. T. Peters, L. C. Dang, and T. Maniatis.** 1998. MEKK1 activates both IkkappaB kinase alpha and IkkappaB kinase beta. *Proc Natl Acad Sci U S A* 95:9319-9324.
 199. **Baud, V., Z. G. Liu, B. Bennett, N. Suzuki, Y. Xia, and M. Karin.** 1999. Signaling by proinflammatory cytokines: oligomerization of TRAF2 and TRAF6 is sufficient for JNK and IKK activation and target gene induction via an amino-terminal effector domain. *Genes Dev* 13:1297-1308.
 200. **Clark, E. A., and G. Shu.** 1990. Association between IL-6 and CD40 signaling. IL-6 induces phosphorylation of CD40 receptors. *J Immunol* 145:1400-1406.
 201. **Ito, H.** 2003. IL-6 and Crohn's disease. *Curr Drug Targets Inflamm Allergy* 2:125-130.
 202. **Holub, M. C., E. Mako, T. Devay, M. Dank, C. Szalai, A. Fenyvesi, and A. Falus.** 1998. Increased interleukin-6 levels, interleukin-6 receptor and gp130 expression in peripheral lymphocytes of patients with inflammatory bowel disease. *Scand J Gastroenterol Suppl* 228:47-50.
 203. **Kishimoto, T.** 1989. The biology of interleukin-6. *Blood* 74:1-10.
 204. **Teague, T. K., P. Marrack, J. W. Kappler, and A. T. Vella.** 1997. IL-6 rescues resting mouse T cells from apoptosis. *J Immunol* 158:5791-5796.
 205. **Atreya, R., J. Mudter, S. Finotto, J. Mullberg, T. Jostock, S. Wirtz, M. Schutz, B. Bartsch, M. Holtmann, C. Becker, D. Strand, J. Czaja, J. F. Schlaak, H. A. Lehr, F. Autschbach, G. Schurmann, N. Nishimoto, K. Yoshizaki, H. Ito, T. Kishimoto, P. R. Galle, S. Rose-John, and M. F. Neurath.** 2000. Blockade of interleukin 6 trans signaling suppresses T-cell resistance against apoptosis in chronic intestinal inflammation: evidence in crohn disease and experimental colitis in vivo. *Nat Med* 6:583-588.
 206. **Pilling, D., A. N. Akbar, J. Girdlestone, C. H. Orteu, N. J. Borthwick, N. Amft, D. Scheel-Toellner, C. D. Buckley, and M. Salmon.** 1999. Interferon-beta mediates stromal cell rescue of T cells from apoptosis. *Eur J Immunol* 29:1041-1050.
 207. **Seegert, D., P. Rosenstiel, H. Pfahler, P. Pfefferkorn, S. Nikolaus, and S. Schreiber.** 2001. Increased expression of IL-16 in inflammatory bowel disease. *Gut* 48:326-332.
 208. **Oki, M., H. Ohtani, Y. Kinouchi, E. Sato, S. Nakamura, T. Matsumoto, H. Nagura, O. Yoshie, and T. Shimosegawa.** 2005. Accumulation of CCR5+ T cells around RANTES+ granulomas in Crohn's disease: a pivotal site of Th1-shifted immune response? *Lab Invest* 85:137-145.
 209. **Mazzucchelli, L., C. Hauser, K. Zraggen, H. E. Wagner, M. W. Hess, J. A. Laissue, and C. Mueller.** 1996. Differential in situ expression of the genes encoding the chemokines MCP-1 and RANTES in human inflammatory bowel disease. *J Pathol* 178:201-206.
 210. **Luster, A. D.** 1998. Chemokines--chemotactic cytokines that mediate inflammation. *N Engl J Med* 338:436-445.

211. **Levine, A. D.** 2000. Apoptosis: implications for inflammatory bowel disease. *Inflamm Bowel Dis* 6:191-205.