



School of Business Economics and Law  
GÖTEBORG UNIVERSITY

---

# WHAT LEADERS CAN DO TO KEEP THEIR KEY EMPLOYEES - RETENTION MANAGEMENT

*Spring Term 2007*  
Supervisor: *Leijon, Svante*  
Authors: *Hedberg, Lisa 810926*  
*Helenius, Maria 820217*

*Master Thesis in Business Administration*  
*Management and Organization*

## **Acknowledgement**

*First, A big thank you to our supervisor, Svante Leijon, doctor of economics and senior lecturer at the institution of business administration, the group of human resource management at the School of Business, Economics and Law, Göteborg University, for all his help, support and guidelines.*

*We would also like to express our gratitude to our respondents who took time to answer our questions in the interviews. They made a great effort, and without their answers we had not been able to make this study.*

*Thanks, to our opponents that gave us valuable viewpoints and constructive criticism.*

*Thanks also, to friends and family that helped us along the way.*

Gothenburg, June 2007

Maria Helenius & Lisa Hedberg

## Abstract

**Background:** retention management is a highly topical subject and an important dilemma many organizations might face in the future, if not facing it already. We believe that the leader plays a key role in employee retention and retention management. The concept of retention management can both have a narrow, and a broader significance. Both parts of its significance are generally included in this thesis. The background of the thesis present a few articles that discuss issues that makes it important for the organization, and the leaders, to work hard with retention management. The research is based on the leaders in the Finnish case company Tradeka. Following key questions are intended to be answered: What are the consequences between leaders actions and employees retention? Which is the leader's role when it comes to retaining employees?

**Purpose statement:** The purpose of the thesis is to investigate and analyze how company leaders today can retain their key employees. How can the provision of key human resources develop a long-term relationship that makes top employees stay in the company? The study aims to establish the procedure leaders apply to retain employees. The purpose is to compare the qualitative study, made at the case company, with findings from the thesis theoretical framework.

**Research method:** The study is a qualitative, as well as a theoretical study where empirical findings and theories has been compared. The intention of investigating and using the Finnish company Tradeka Limited as a case company, is to make the information from the theories more valid, and also the interest in how retention management works in practice. Eleven qualitative interviews were conducted at Tradeka's financial department, both with supervisors and employees to get a broader view at the phenomenon retention management.

**Result:** Leaders and their skill in creating a culture of retention, has becoming a key in why people stay and what usually drives them away from a company. The leader has become the main factor in what motivates people's decision to stay or leave. For organizations to keep its key employees their number one priority should be to look at their management, because people leave managers and not companies. Characteristics in a leader that are of importance, as the leader plays a key role in retention management is: trust builder, esteem builder, communicator, talent developer and coach, and talent finder. The leader's relation to the employees plays a central role in retaining employees, because employees need to feel involvement, and that their presence count. When retention is a core value, good things happen for customers, employees, and the company.

**Keywords:** retention management, key organizational members, employee turnover, communication, leadership, motivation, recruitment

# Table of Contents

<b>1. Introduction</b> .....	1
1.1 Background .....	1
1.2 Problem discussion.....	3
1.3 Problem areas .....	3
1.4 Project purpose.....	3
1.5 The case company .....	4
1.6 Perspective .....	4
1.7 Disposition of the project .....	4
<b>2. Theoretical framework</b> .....	5
2.1 Retention management.....	5
2.1.1 Voluntary turnover .....	6
2.1.2 Job satisfaction .....	7
2.1.3 Job alternatives .....	8
2.1.4 Retention plan .....	9
2.1.5 Knowledge retention .....	10
2.1.6 Reasons for employees leaving .....	11
2.2 Key employees .....	12
2.2.1 Recruitment .....	12
2.2.2 Motivation .....	13
McGregor's Theory X and Theory Y.....	14
2.3 Good leadership.....	15
2.3.1 Leader's role.....	15
2.3.2 Leadership and understanding.....	16
2.3.3 A consultative leadership .....	17
2.3.4 Communication theories .....	18
2.3.5 Communication models.....	19
2.3.6 Feed-back .....	20
2.3.7 Organizational structure .....	20
2.4 Summary of chosen theories .....	21
<b>3. Methodology</b> .....	22
3.1 A qualitative study .....	22
3.2 Empirical findings .....	23
3.3 Data processing - Primary and secondary sources .....	24
3.3.1 Interview in practice.....	24
3.3.2 Description and motivation of chosen respondents.....	24
3.4 Criticism.....	25
<b>4. Empirical findings</b> .....	26
4.1 History .....	27
4.2 Chains.....	27
4.3 Our findings from supervisors.....	28
4.3.1 History of voluntary turnover.....	28
4.3.2 Leader's role.....	28
4.3.3 Communication and understanding.....	31
4.3.4 Challenges .....	32
4.3.5 Recruitment .....	32
4.3.6 Difficulties with retention management.....	33
4.3.7 Improvement of retention management .....	34
4.4 Our findings from employees.....	35

4.4.1 Leader's role.....	35
4.4.2 Communication and understanding.....	36
4.4.3 Challenges .....	37
4.4.4 Improvement of retention management .....	37
<b>5. Analysis</b> .....	39
5.1 History of voluntary turnover.....	39
5.2 Leader's role.....	40
5.3 Communication and understanding.....	42
5.4 Challenges .....	44
5.5 Recruitment .....	44
5.6 Difficulties with retention management.....	45
5.7 Improvement of retention management .....	46
<b>6. Conclusion</b> .....	48
6.1 What we have learned .....	48
6.2 Recommendations .....	51
<b>List of References</b> .....	52
<b>Appendix 1</b> .....	55
<b>Appendix 2</b> .....	56
Explanation of concepts: .....	57

## Table of figures

<i>Fig. 1: Schematic diagram of a general communication system (Shannon &amp; Weaver, 1949: 5)</i> .....	19
<i>Fig. 2: Compiled model regarding the theories</i> .....	21
<i>Fig. 3: Tradeka's organization chart (Tradeka Ltd, 2000 B)</i> .....	26
<i>Fig. 4: Compiled analyze model about supervisors</i> .....	35
<i>Fig. 5: Compiled analyse model about employees</i> .....	38

# 1. Introduction

---

*The introduction chapter will explain the concept of retention management and discuss the background of the investigation. A short presentation of our case company Tradeka will be made. The aim is to enlighten the reader about the problem formulation, the purpose of the research, perspective, and finally will the disposition of the thesis be presented.*

---

We feel that retention management is a highly topical subject and an important dilemma many organizations might face in the future, if not facing it already. The reason for the interest in this subject started from our previous studies, as well as, we have noticed changes regarding the issue of retention management. Previous research has given us the idea to consider this issue from a leader's perspective. The research is based on the leaders in the company, as we believe that the leader plays a key role in employee retention and retention management. The background of the thesis will present a few articles that discuss issues that make it important for the organization and the leaders to work hard with retention management.

## 1.1 Background

The concept of retention management can both have a narrow, and a broader significance. Both parts of its significance are generally included in this thesis. To understand the concept of retention management we would like to explain what we mean by retention management in this investigation. The retention management concept includes: motivation, recruitment, rewarding, employee job opportunities, work environment, the role of leadership, as well as communication and understanding. We believe that the most important topic to discuss in retention management is the leader's role and what consequences his/her decisions may cause. Organizations give the following definition to retention according to Wikipedia (2007 A): *keeping personnel within the organization from departing. Management objectives are to direct and control a group of one or more people for the purpose of coordinating and harmonizing that group towards accomplishing a goal.*

*Management role is with power by position, whereas leadership involves power by influence. Management operates through various functions, often classified as planning, organizing, leading/motivating and controlling* (Wikipedia, 2007 B).

The labour market today does not look like it used to. Voluntary turnover is according to Mitchell et al (2001) a huge problem for many organizations. The retention issue is an important topic and managers need to face the problem of job hopping. As Wolmesjö (2007) describes it in an interview with Per Åström, the recruitment manager for Proffice in the Nordic region, the companies need to entice employees with something else than salary. Furthermore Åström says:

*“You need to be the good employer and offer well functioning working places with a big amount of freedom.”*

(Göteborgs-Posten, Jobb-Studier, 2007: 1)

The labour market today is growing and changing fast. It is the responsibility of the leader in the organization to adapt to these changes to be able to make the organization profitable. To be able to do this, it is crucial to retain the key employees in the company since they are the ones which drive the company forward. According to an article in Knowledge Management Review by Young (2006), companies are faced with people leaving to join other companies. The average worker is changing jobs ten times between ages of 18 and 37 continuously. Young says that one answer to this issue is to believe that you can purchase knowledge to replace what you are losing. Another article in Industrial Distribution by McCrea (2001) says that employees today change jobs frequently and do not have the company loyalty that existed 30 years ago when your valued employees were hired. The article, The battle for brainpower (2006), also states that loyalty to employers is fading. Thanks to downsizing, job security in return for commitment has been breaking down. Also replacing retired workers has become quite a challenge because of the low unemployment rate. According to Wolmesjö (2007) the companies should have tried to predict the future recruitment needs and hired people when the economic cycle was in a recession. The ones who hire during the economic upswing are in a dangerous situation.

The generation today also makes the situation different regarding the work force according to Alch (2000). The followers of Generation X, the Net Generation, also called the Echo-Boom Generation, are people born between 1977 and 1997. These people are right now in the industry and continuously entering the work force in stages, approximately 15 years from now. The Net Generation's values and culture have to be faced by employers. The employers need to know what to expect from the Net Generation in order to attract and retain those talents and align them with corporate goals. Alch (2000) says that the 80 million Net Generationer's will easily displace their parents, the baby boomers who number 77 million. People from the Net Generation who are entering the work force are starting to quietly past Generation X'ers to occupy centre stage. The Net Generation is the first generation to grow up in the digital age, they are technologically intelligent, mobile and cool with chaos. Current management practices might be shaken up as the Net Generation has a great affect on how work will be done. As they strive for a lifelong learning this may affect employee retention. They do not expect or want lifelong employment and company loyalty. The Net Generation also has more respect to learning, then to hierarchical systems and loyalty. They are comfortable with changes and more conversant with a communications revolution transforming business, education, health care, entertainment, and government, then any other generation. Companies and leaders will need to find new ways to motivate and retain the incoming workforce.

It may be a conflict between a high educational level and the labour market. Highly educated people might feel that they cannot be offered a challenging job at home, so they look for jobs in other countries. Competition within companies needs to be higher in order to compete with the global market. To be globally oriented, makes it easier for the Net Generation as they understand other cultures, and they are not afraid to face these differences. According to the article, The battle for brainpower (2006), companies need to raise productivity by managing talent better. The hunt for talent has gone global as the globalisation creates demands and opportunities of/for educated people. A good act for companies is to use universities as magnets for talent, and to get contact with student at an early stage. An ageing work force makes companies fight harder for talented young employees, as well as learning to manage new sources of talent.

## **1.2 Problem discussion**

The thesis focuses on how leaders can in the best possible way, keep their key employees through retention management.

An organization with strong leaders and a well developed and functional retention plan are more likely to succeed. It is important for the leaders to think in the long-term as there might be fewer highly educated people in the market to choose from, due to a changing workforce. Companies continue to grow and globalisation gives the opportunity for employees to find jobs elsewhere. To avoid this situation the organization needs to plan ahead and look at retention management in the long-term.

We are studying retention management from the perspective of the leader's in the company, because we want to find out whether the leader can influence the employee to stay in the company or not. In order to help our reader understand how leaders can prevent key employees from leaving the company it is of big importance that the communication and the leadership in the organization are well-integrated. Together, they can improve their role as a leader through communication and motivation. Another aspect that needs to be taken into consideration is recruitment, as this is a factor that definitely influences the employees. The recruitment process plays an important role in employee retention. The "perfect match" might be more important to companies than they think.

We believe that the problem for leaders to retain their key employees can be linked to the organizations structure. If the structure (in terms of unclear work tasks etc.) of the organization is problematic this might lead to an increased voluntary turnover. Voluntary turnover can be good to an extent but there needs to be a balance. Turnover needs to be natural in the sense that some employees leave and new employees enter.

## **1.3 Problem areas**

The basis of the problem discussion above, leads us to the following key questions.

- What are the consequences between leaders actions and employees retention?
- Which is the leader's role when it comes to retaining employees?

## **1.4 Project purpose**

The purpose of the thesis is to investigate and analyze how company leaders today can retain their key employees. How can the provision of key human resources develop a long-term relationship that makes top employees stay in the company? The study aims to establish the procedure leaders apply to retain employees. Throughout the study we will concentrate on the leader's perspective which hopefully brings that a more determined analysis is created. The purpose is to illustrate the leader's view of retention management, through making a qualitative study.

Interviews will be made at the financial department in a Finnish company called Tradeka Limited. The purpose is to compare the qualitative study, made at the case company, with findings from the thesis theoretical framework. Therefore the study will be a qualitative, as well as a theoretical study. The intention of investigating and using a case company is to make the information from the theories more valid, and also the interest in how retention management works in practice.



## **1.5 The case company**

Tradeka Limited is a retail company which owns all of its centrally managed retail outlets. The business is divided into the following three nationwide store brands: Siwa, Valintatalo and Euromarket. Tradeka reported a net turnover of EURO 1.3 milliard in 2006. The company owns around 750 grocery stores in Finland, and three outlets in St. Petersburg, Russia. Tradeka Ltd is a major employer, with approximately 7,000 employees. It is a market leader in neighborhood shops and largest chain. Tradeka Ltd is continuously developing and expanding, proactively looking for new sites. In response to needs of each store, one of Tradekas's main objectives is to improve service concept including store specific product mixes. Tradeka's employees maintain the organization's values in their work. Values are customer focus, team spirit, trailblazing, and hunger for results (Tradeka Ltd, 2007A).

## **1.6 Perspective**

To take a closer look at the difficulties that arises in retention management, this thesis will focus on the perspective of the leaders in the company in order to delimit the study. We will investigate the leader's role and their effort to retain employees. To support the leader's role in retention management we will also investigate the role of communication, motivation and recruitment effects on these issues. This will give us the opportunity to clarify the problems that the project is based on.

## **1.7 Disposition of the project**

The introductory chapter is the fundament of the thesis and describes in what way the phenomena is interesting for the investigation. Chapter two presents the theoretical framework where retention management, key employees, and good leadership will be described further. The intention is to compare and discuss the chosen theories on what will be found in the qualitative study. The third chapter explains the chosen methodology of gathering knowledge and information. The qualitative study will be explained, as well as the procedure of the investigation in the case company Tradeka. The empirical study will be made thru interviews with leaders in order to analyze their answers and what they believe can be made in order to keep key employees. The aim to make an empirical study is to get more validity and to be able to compare answers from the interviews with the thesis theoretical framework. The case company was contacted because of previous working contact with the company. A comprehensive explanation on the empirical findings of Tradeka is presented in the fourth chapter. The findings from the interviewed supervisors and employees will be presented through different themes.

The fifth chapter contains the analysis of the collected material where empirical findings will be compared with the theories. The weak links that might be found between the reality and the theory will be discussed, as well as some own ideas and thoughts. Finally, the sixth chapter presents the conclusions of the thesis. The conclusion will include what we have learned, where the results of the investigation, are answered through the thesis research questions. The chapter ends with recommendations for future studies.

## 2. Theoretical framework

---

*The chapter assembles theories which concerns retention management. The chapter will be divided into retention management, key employees, and good leadership. Furthermore is retention management described and connected with existing theories, such as recruitment, motivation, leadership, and communication. In the beginning of each heading, will a motivation be made, on why the particular theories have been chosen.*

---

### 2.1 Retention management

The main theory for this thesis is retention management and the concept will here be discussed in a broader meaning. Various subjects regarding retention management will therefore be presented under this headline. The section will first discuss voluntary turnover. Voluntary turnover can be seen as a threat for companies as it might cause loss of key employees. Some amount of turnover is natural, but we would like to point out the problems that can arise if voluntary turnover start to increase. The importance of job satisfaction will be shown because of the great importance in satisfied employees, in order to be motivated and enjoy one's work. Job alternatives discuss reasons for employees to leave their job, and that it does not have to be because of job dissatisfaction. Employees want to feel appreciated and feel involvement in the organization, therefore we believe that retention plans need to be considered. Knowledge retention discusses why it gets crucial with employee awareness, in order to prevent key employees from leaving.

To retain top employees in companies there is an intense competition. In order to figure out how to keep employees from leaving, leaders and HR departments spend large amounts of time, effort, and money. Reasons for people to leave are often unrelated to their jobs, where unexpected events or shocks can be the cause. Employees can on the other hand stay in their jobs because of attachments to the company, or the sense of affiliation (Mitchell et al, 2001). Therefore, it is extremely important for leaders to have a well developed retention plan for each of their employees, in order to make them stay in the company and to help them motivate themselves to do a good and inspiring job.

The reasons why employees voluntary leave organizations are many, in accordance with Mitchell et al (2001: 96), people often leave for reasons unrelated to their jobs:

- Personal risk
- Desire to learn a new skill
- Trade
- An unsolicited job offer
- Unexpected events or shocks:
  - unfair treatment of a co-worker
  - being passed over for promotion
  - being asked to do something against one's beliefs

On both the individual level and the organizational level, turnover imposes extensive costs according to Mitchell et al (2001). At the individual level, no matter if the person leaves voluntarily or is forced to leave, the transitions to another job or situation take a personal toll. The estimated time for adjustment to be made and a career to get back on track is up to one year, and probably in some cases even more. The problem for the

organization arises when departing employees take their valuable knowledge and expertise gained through experience with them. Close relationships with clients that they have established is not that easy to rebuild. Even worse are the costs directly related to the turnover that organizations face. This turnover inflicts numerous costs for the company, such as:

- Exit interview time and administrative requirements
- Payout of unused vacation time
- Cost of temporary workers
- Overtime for co-workers asked to fill in
- Formal and informal training costs
- Replacement costs: - advertising
  - processing of candidates
  - interviewing
  - selecting

There are not just some types of companies that need to engage in a struggle to retain talent. Organizations of all sizes need to actively work on these issues.

### **2.1.1 Voluntary turnover**

Unwanted employee turnover is one of the biggest and most costly business problems companies' face and it remains pervasive and persistent according to Taylor (2002). Continuously Taylor argues that undesirable, unwanted, and voluntary attrition that companies experience when highly valued employees quit to take another job elsewhere, is a much bigger problem than the frequency of corporate layoffs reported.

There are a few secrets to minimizing turnover according to Boyens (2007: 62):

- Proactively manage rewards, respect, and requirements of turnover (the three R's of turnover)
- Create a culture where all employees can thrive
- Practice proactive, consistent, and clear communication
- Know what motivates each employee and act accordingly
- Do a better job hiring the right employees

Employee retention is increasing in importance as the competition for talent is high and still growing. The solutions to improve retention management are usually assumed to hinge on assessment, selection practices, and on increasingly comprehensive HR programs and services. Competitive salaries, comprehensive benefits, employee services, incentive programs, and similar initiatives are important when attracting and hanging on to employees but pay and programs are at risk of becoming commodities. It is not hard for a competitor to compete with individual elements of employment such as salaries and benefits (Taylor, 2002).

Boyens (2007) focuses on the reasons of involuntary turnover, voluntary turnover, and promotion for employees to leave a particular company. Furthermore, he says that the two types of turnover are the most devastating for organizations. The effect of voluntary turnover includes loss of performance, knowledge, expertise, relationship, and loss of the time and resources that it took to train the employee. Employees will balance the organizational themes rewards, respect, and requirements of turnover in their decision to remain in a company, which Boyens calls the three "R's" of turnover. *Rewards* are

considered as base salary, commission, benefits, education opportunities, vacation time, and retirement plans. The employee need to be *respected*, meaning the way they are treated, work environment, personal and professional growth opportunities, recognition and, implementation of their ideas. The *requirement* of having clear defined job duties, realistic goals, and expectations makes the employee feel affiliation to the organization. Businesses that successfully reduce turnover align goals and expectations invest in their employees and professional development of their people. Input on a regular basis should be asked from employees, as well as consistently review any potential source of dissatisfaction.

According to researches in Taylor's (2002) article, there is one particular factor that motivates people's decision to stay or leave. Leaders and their skill in creating a culture of retention are emerging as the key in why people stay and what usually drives them away. For organizations wanting to win the fight to keep its best talents, they firstly have to look at their managers. People leave managers, not companies. People join organizations for attractions like salaries and benefits but they leave for other reasons.

Furthermore Taylor (2002) says that employee retention is one of the biggest unmet opportunities in organizations today. When retention is a core value in the organization good things happen for customers, employees, and the company. Through an integrated strategy you achieve the best results. The biggest recompense of a retention strategy is development of a culture that recognizes people as individuals. People need to be treated individually and be understood for their uniqueness in order for the company to be successful.

### **2.1.2 Job satisfaction**

Employees that are satisfied with their jobs have a positive experience of their pay, supervision, chances for promotion, work environment, and tasks. Job satisfaction is associated with job enrichment, good supervision, clear roles, and met expectations (Mitchell et al, 2001). Job satisfaction is influenced by economic factors, such as pay, benefits, and rewards, as well as structural and procedural factors reflecting autonomy or fairness. Wallgren et al (2006) write in accordance with Robbins that management should put a lot of effort into increasing employee job satisfaction because of the correlation between satisfaction and productivity. This correlation regards the impact job satisfaction has on productivity, such as employee well-being, absences, and turnover.

Hislop (2005) writes in accordance to a report made of Buck & Watson on research into how HRM practices in higher education institutes in the USA, affected levels of organizational commitment and turnover amongst employees. A positive correlation was found between level of job enrichment and commitment, and a negative correlation between training and organizational commitment. Affiliation was developed through job enrichment practices, such as providing workers with high levels of discretion and autonomy. The provision of training of employees may have a negative effect on commitment levels. The training which provide the employees with more marketable skills, raise their awareness of pursuing a career where the benefits are higher.

Improvement in the company's job satisfaction and culture can be made through creating a positive work environment. Examples of a positive work environment are clean

facilities, comfortable and ergonomic furniture, current technology, break rooms, kitchens, and ample parking (Boyens, 2007).

Mitchell et al (2001) believe that satisfaction in the work place is important for staying and management techniques probably contribute to it. They also mention recommendations in order to solve turnover problems like; frequent and honest communication, fair and equitable compensation, and clear performance expectations. Pay and financial incentives also work to increase motivation, commitment, and satisfaction.

### **2.1.3 Job alternatives**

People that find their jobs unsatisfying will sooner or later look around for alternatives. If there are more alternatives it is more likely that people will leave faster. Causes for dissatisfaction can be stress, repetitive work, role ambiguity, and work overload. Regarding turnover that we talked about before, job dissatisfaction has been described as the most important and frequent cause of the turnover process. People search for alternatives and compare them with their present job (Mitchell et al, 2001).

Causes for voluntary turnover can be attitudes about a person's current job and available alternatives. If the employee is satisfied with his/her current job, he/she will be less attracted by alternative jobs. Other attitudes like organizational commitment, job involvement, and perceived organizational support are things that need to be taken into consideration. Employees expect to have many jobs during their careers. According to Mitchell et al (2001) the prevailing perspectives on leaving and staying are too narrow.

According to Mitchell et al (2001), people first thoughts about leaving arise in response to some particular event that they call: a shock to the system. Frequently found shocks are mergers, unsolicited job offers, friends leaving, having a baby, spouse relocation, a poor performance appraisal, and administrative changes. The different shocks are: Positive, negative, neutral, expected, and unexpected. Whether the shock is expected or unexpected, thoughts about leaving the company are followed.

In Mitchell et al (2001: 99-100) survey, they developed a model they called the unfolding model. The model describes four different paths people can take when they leave a job. Three of the paths are initiated by events that made people questioning staying in the company, and not because of job dissatisfaction.

1. Following a plan: is characterized by a shock to the system and a plan already in place for leaving. This plan can for example be if they get accepted into an educational program or if they or their spouse gets pregnant. Temporary or part-time workers usually quit after working for some specific amount of money. Dissatisfaction is not the cause and there is no search for alternatives.
2. Leaving without a plan: starts also by a shock but without a plan in place, the person leaves without searching for alternatives. The shocking event is often negative, and involves such unexpectedness that negative emotions, like distrust or anger follows the leaving process.
3. Leaving for something better: the person considers alternatives and leaves eventually with another job in hand. The shock possibly leads to minimal job

dissatisfaction as being an unsolicited job offer. These people are not dissatisfied with their jobs, they just get an offer they cannot resist because the alternative is better.

4. Leaving an unsatisfying job: job dissatisfaction leads to quitting in two different ways. Firstly, the employee become dissatisfied and leaves without searching because their current job is not where they want to be. The second way also includes job dissatisfaction and the person look for and evaluates alternatives. Dissatisfaction as cost cutting, increased workloads, continuing problems with work schedules and work assignments leads to search, which leads to leaving.

Job embeddedness and staying includes factors discussed earlier such as job satisfaction, organizational commitment, and perceived organizational support. If employees believe the organization is committed to them, they stay. Job embeddedness reflects on- and off-the-job factors that keep people in their current positions. According to Mitchell et al (2001), job embeddedness consists of three factors; links, fit, and sacrifice.

Links are the connections between a person and other people, groups, or organizations which are important to the job. Mentor systems can be used to increase the attachment between leaders/employers and employees, also called link-building activities. Companies can also provide new employees with information on resources and activities in their communities.

Fit is an employee's perceived compatibility with job, organization, and community. The turnover will become lower if employees fit with their jobs, co-workers, and corporate cultures. The use of flex-time is an organizational option that is widely used because it helps to fit the individual's off-the-job environment. Flexible schedules have also been ranked as the most effective retention tool. Other strategies for fit could be to give people a better chance to sync with their off the job activities, such as shorter work weeks, telecommunicating, or part-time work. Companies need to recruit their good performers and jobs should be customized.

Sacrifice reflects the cost of what people need to give up if they leave a job. Retention bonuses, retirement funds, and stock options help to keep employees in their job. Benefits like these can though be matched by what competitors offer. Sacrifices can involve programs or activities that are more long-term or personal focused. Long-term development plans are worked out with the employee and investments are made in training and education that will help the employee's performance. Things like child-care support that relates to personal situations are also of big importance for the employee to sacrifice.

#### **2.1.4 Retention plan**

In order to develop a retention plan, several on-the-job and off-the-job factors must be considered, according to Mitchell et al (2001). The leader must investigate these factors and select those which are the most applicable to the firm. There are a few key findings when developing a comprehensive retention plan.

First, the leader need to make strategic decision and determine whether turnover is a problem. Conclude why people are leaving and arrange exit interviews made by outside

consultants so the leaver does not fear retribution. The leader also needs to investigate the reasons and factors why people stay in the company. Top-level support needs to be developed for the plan, as well as spending financial and human resources on the planning. Second, the organization should pay close attention to basic management practices, such as job satisfaction and organizational commitment. Gather feed-back of this data and prepare to make changes. The third thing to do, is to apply the unfolding model and its four different paths. The model high-lights some important practices for the development and implementation of retention plan. The leaving process is in many cases initiated by shock which can help the organization to identify the types of events that make people leave. To learn the distribution of shocks across paths help the organization to get a feeling for what initiates the process. There is also a need to analyze the content of the shocks, and to use realistic job previews for new employees. Prepare people for potential shocks to reduce the anxieties that for example mergers or annual performance appraisal period can be. An open communication flow will make sure that reasons, procedures, and events are clearer.

Furthermore, job embeddedness can be established and maintained through careful attention to the connections employees make to people, institutions, and activities outside and inside the organization. Every employee needs to be considered, therefore the company should ensure a good fit with the job for each employee. Using personal development plans will provide employees with opportunities throughout their career.

It is important to have in mind that retention plans or programs require an overall, comprehensive, thoughtful process to be effective. Plans are expensive and vary across organizations and industries, as well as they need substantial effort. To enlighten the problem about employees leaving, actions need to be taken as these programs compete for talent (Mitchell et al, 2001). To keep the most valuable people in the companies, it has becoming popular to give employees retention bonuses. Retention cannot be accomplished purely through money, as positive effects of more pay, usually are short-lived.

### **2.1.5 Knowledge retention**

Knowledge retention is an issue that is challenging organizations all over the world according to Young (2006). Knowledge retention takes time, skill, and resources. To ensure effective knowledge retention in an organization is crucial, so that valuable knowledge assets do not disappear. The need for knowledge retention is a global issue as the average worker changing jobs ten times between the ages of 18 and 37 according to Young (2006). Companies can no longer expect to buy in knowledge into the organization for reasonable prices as demand outstrips supply, they need to focus on retaining knowledge and their talented employees. To prevent the organization from experiencing lack of talented employees due to a higher demand, is to retain knowledge when people leave and make it available to new people as they join the organization. The risk that knowledgeable and valuable personnel will leave as soon as they get a better offer will be greater if the demand for employees is high. To try to be ahead of competitors it will be helpful to deploy knowledge retention strategies. Before starting a program on how to retain the knowledge in employees and team members, there are a few questions that need to be asked according to Young (2006: 29):

- What is the key knowledge we need to protect as a company?
- What are the crucial areas of knowledge for our future success as a company?

- Which areas of knowledge are the most valuable?
- Which areas of knowledge are most at risk of loss through personnel loss?
- Which areas of knowledge could be easily replaced when lost and which are irreplaceable?

The most irreplaceable, high-risk areas are where the company's knowledge retention efforts need to be focused. It is vital for the organization and for the leaders to know their employees and to identify exactly the knowledge that a person have, and upgrade it with their help and input from other colleagues.

### **2.1.6 Reasons for employees leaving**

Seven hidden reasons why employees leave are according to Branham (2005): lack of recognition (including low pay), unfulfilling jobs, limited career advancement, poor management practices, untrustworthy leadership, and dysfunctional work cultures.

1. The job or workplace was not as expected
2. The mismatch between job and person
3. Too little coaching and feed-back
4. Too few growth and advancement
5. Feeling devaluated and unrecognized
6. Stress from overwork and work-life
7. Loss of trust and confidence in senior

Young (2006) talks about knowledge management and brings up six common reasons for employees leaving. These are the following; leaving for a better job elsewhere, retirement, promotion, relocation, downsizing, external factors, and temporary workers. Employees are leaving for a better job elsewhere because of better prospect or for more money. The employee's relationship between the company and the leader is the key on how events will develop. If the employees are unhappy it is more unlikely for them to cooperate with any knowledge capture or retention exercise, then if they are happy with their employer. Retiring employees usually have knowledge that the organization needs to retain. However, only part of what the retired person has done in their career will be of value to the organization, so the organization needs to try capturing that valuable part in another person. Promotion for an employee to a new job in the organization can become a big loss of knowledge. To solve this, a knowledge retention process can be used to create a knowledge asset for the benefit of the coming employee. The knowledge asset that is being created will provide a support mechanism for the former colleagues. Relocation happens when someone moves from one location or post to another firm to explore and to gain experiences and learning's. Downsizing and external factors can lead to an unacceptable risk of knowledge loss. There are also a growing danger globally that many young professionals from all cultural backgrounds immediately after graduating from university look outside the country for employment. By temporary workers Young (2006) means that some situations will make the organization engage temporary personnel to conduct a special project or to manage a spike in workload. This might lead to a will to retain these people for later use.



## **2.2 Key employees**

Theories that are discussed in this section are recruitment and motivation, as we believe that it is important to recruit key employees that are motivated in order to keep them. McGregor's theory X and theory Y gives the reader a view of how successful management depends upon the ability to predict and control human behaviour, and how motivation of employees are influenced in relation to the management's practice.

Characteristics for key employees are that they are motivated in their work. They are loyal to the company, they are driven, and have a desire to learn new tasks, open to new ideas, and not afraid of changes. The concept of key employees separates them from other employees in terms of their conviction and desire to personal development. Key employees can be distinguished from other employees in the sense of fit to the company, and understanding of working tasks and organizational values. A key employee can differ depending on a certain company. The employee's education in the field should match with the working tasks.

It is hard for companies to know which people that might become their key employees in the near future. In order to make a "good match" from the beginning, it is important to put effort into recruiting the "right" people from the start. To recruit key employees, the recruitment process should be structured in a way which let both the organization, and the employee, know as much as possible about each other. Once the employees are hired, they need to be motivated in their work in order to achieve good results and enjoy the job.

For an organization to lose key employees, they announce their vulnerability and how much it means to them to keep them in the company. To maintain and establish an important relation, will make them strong, but in the same time, they also need to be aware of what a loss of a key employee might cause. The company usually spends money into educating the employee. The employee has key information about the company, and will develop professional skills that can be hard to transfer to someone else. Key employees are committed and see their future in the company.

### **2.2.1 Recruitment**

The work market and work tasks changes fast nowadays (Capotondi, 2002). Therefore it is important to think in the long-term when it comes to recruitment, find the right employees, recruit them, and motivate them to stay in the company. The termination of employees has to be a natural part in the organization according to Capotondi (2002).

For companies to prevent themselves to suffer from voluntary turnover they should put in a great effort to hire the right employees (Boyens, 2007). It is easy for the interviewer to switch from interviewing the person to trying to hire the person, and this often happen due to lack of time. Depending on the size of the company it is important to always look for good talent and once hired, the company must work hard to retain the employees according to Miodonski (2005). Many companies today are using employment agencies to fast get help to find suitable employees. This might be a good solution in the short-term but this type of hiring can be questionable in the long-term.

Organizations can face difficult situations when key employees retire. Replacing retiring workers is a big challenge with the unemployment rate hovering nationwide (McCrea,

2001). A way to soften the difficulties of replacing retired employees is to have succession planning in order to make the transition smooth. Succession planning needs to be considered years in advance. The plan should include information about each employee, and exactly which paths each would most prefer to travel as they move up through the ranks of the company. It is important to identify the employees' strengths and weaknesses, and then create a future plan that helps the employees move into positions where they can grow and thrive. Even with a recession plan in place complications can arise as the company suffers the loss of a key employee. One option is to let the retired employee's cash in on their pension benefits where previous employers can invite them back on a consultant basis.

The article by McCrea (2007: 64-65) brings up ten ways to prepare for the day their key employees leave the company. We have chosen to focus on five of the tips that we feel are of crucial importance.

1. Look inside the organization for internal resources, as the critical shortage in talent resulting from retirement do not have to be filled from the outside. An average player can become a star when the opportunity is given.
2. The company might be able to entice a potential retiree to stay on, retirement does not mean "65" anymore. There is also the option of using the retiree's services in a consulting capacity.
3. Start prepare in time. Make an "early identification" and know who your key players are. Develop a five-year plan for each one, ask and establish trust. Careful planning should start a year or more in advance of the big day.
4. Communicate with other employees and show interest in people. The employees need to know what is going on during the retirement process, inform them what the company is doing to make the transition as smooth as possible. Have an open-door policy.
5. For companies to be successful they need to take a different approach to employee hiring and retention. Mentors should be given to the employees, as human resources are just a support. Proper mentoring requires an investment from the company itself. For a period of time there will basically be two employees doing the same job.

### **2.2.2 Motivation**

The employee's motivation to work and will to make an effort cannot, according to Bergström (2006), be given through someone else than the individual himself. The leader (or someone else) can although influence the motivation that is already inside the person and the leader can be there as a mainstay. Furthermore states the article *Re-recruit your best employees to retain them* by Miodonski (2005) that you absolutely cannot motivate another person as people get motivated by different things. Thus, an environment can be created for people to motivate themselves. Motivation varies depending on the situation according to Scheuer (2000). This requires special analysis to appoint what stimulate or decrease work motivation. Dynamic motivation is dependent on human expectations, the norms at the workplace, private issues, and the individuals working tasks.

Boëthius & Ehdin (1993) believes that people who has committed development into themselves, and who creates good results, does not need someone else to motivate them. To be motivated it is crucial to follow the conviction and the want to perform well, because that is what creates meaning at work. The leader's task is to give the employees

the conditions to find the conviction. Furthermore, Boëthius & Ehdin (1993) discuss the internal and external motivation. The external motivation gives the possibility to push from behind, and at the same time entice from the front with rewards. This motivation will increase the expectations of bigger rewards. The internal motivation is firmly rooted in the person and what he/she find meaningful. To follow what gives meaning will help the person to find the right way and release unexpected powers. It also makes the employee freer to take own decisions. To create the right conditions for the internal motivation, two things are demanded, according to Boëthius & Ehdin (1993): First, the company need a well functioned value system which is clearly communicated. The value system creates the vision and the goals in the company. The company values need to be work out thoroughly and intended in an honest way. The second condition in order to create the internal motivation, is that the employee needs to know their own values, and what they value the most. If the values are agreed with the organizational values, the chance is greater to find meaning in work and act in accordance with personal potential. The internal motivation increases the pleasure of work and the results (Boëthius & Ehdin, 1993). This is why it is important to try to find the companies key employees from the beginning, someone that will fit into the company values.

Employees are motivated by different things as mentioned above. Boyens (2007) means that it is important for the leader to know what motivates each individual. If unsure, find out by asking the employees. The leader should get to know the employees as people before getting to know them as employees. This knowledge will help the leader to recognize and reward them individually.

Capotondi (2002) states that the organizations responsibility is to recruit, organize, reward, communicate and windup in a way that is functional. It is crucial with adaptation for the company to be profitable. A leader needs to know his/her employees and understand that not everyone is like-minded (Capotondi, 2002).

## **McGregor's Theory X and Theory Y**

McGregor (1960) means that managers must have the right conception of employee's motivation, in order to increase their effectiveness. Successful management depends significantly upon the ability to predict and control human behaviour. McGregor's models theory X and theory Y describes two distinguish assumptions in employees behaviour. The motivation of employees is influenced in relation to the management's practice.

Theory X is representative of a manager influenced by the most negative aspects of classical management theories. Management is responsible for organizing the elements of a productive enterprise, such as money, materials, equipment and people in the interest of economic ends. With respect to the employees, the manager directs their efforts, motivates, controls and modifies their behaviors to fit the organization needs. "*The average human being has an inherent dislike of work and will avoid it if he can*" (McGregor, 1960: 33). Without active intervention by management, people would be passive to organizational needs. Employees activities must be directed, they need to be persuaded, rewarded, punished, and controlled.

The manager in theory Y on the other hand, is one who adheres to the precepts of the human relations movement. "*The expenditure of physical and mental effort in work is as*

*natural as play and rest*” (McGregor, 1960: 47). The employee exercise self-direction and self-control in the service of objectives to which he/she is committed. Commitment to objectives is a function of the rewards associated with achievement. The average human being learns to seek responsibility. Employees are highly motivated to satisfy achievement and self-actualization needs. The job of the manager is to bring out the natural tendencies of these intelligent and motivated workers.

## **2.3 Good leadership**

Good leadership and theories concerning this topic will be discussed, such as leadership and understanding, communication, feed-back, and organizational structure. We will talk about the leader’s role because of its importance to retention management. Furthermore, we believe that leadership and understanding is significant in a person’s comprehension of her/his work. A consultative leadership gives the employees more responsibility, which we think increases the motivation. Communication is important because it is central in the translation of goals into action. To retain employees in the organization there need to be a well functioned communication, as it is an ongoing activity by which the members of the organization make sense of information. Shannon & Weavers “Mathematical Theory of Communication” will be pictured to show which logical theoretical demands an information system need to fulfill, in order to transfer a message from one source to another. Communication and feed-back help the employee’s and the leader’s to understand each other, because feed-back help the communicator to adapt the message to the receivers need and response.

A leader needs to be able to lead himself/herself in order to lead others, regarding to Lind Nilsson & Gustavsson (2006), as well as knowing where others are placed. The employee needs to understand what is going on in the company to be able to do the work right, and it is the leader’s task to make sure that the employee knows what is expected.

### **2.3.1 Leader’s role**

Employees want a leader who knows them, understands them, care, concern, treats them fairly, and is someone whom they can trust. The leader need to know what their employees want and what is important to them. Retention management and retending employees is about relationships. People need to feel like their contributions to the organization are valued (Taylor, 2001). To keep good people involved in the company, leadership is important regarding Miodonski (2005), employees want to be part of the game. As a leader it is important to listen to all employees in order to get ideas and advises (Hägglund & Larson, 2003) People power becomes important because the organizations people are something that competitors cannot copy. Attention needs to be paid to the key employees, or someone else will. Organizations cannot just find good people, they also need to retain their people by giving them training and education. Hägglund & Larson (2003) states that a good leader makes sure those unsuitable employees get a more suitable job within or outside the organization.

The most important element in retention according to Taylor (2001: 27) is the leader. It is the leader who makes the difference and is the face of the company. Accountability for retention has long been the domain of HR, so transferring part of that responsibility to operations and leaders is a cultural shift. For leaders to embrace their part in retention as well as learning new skills and behaviour, they need to be provided training and support

to perform their new role. Furthermore, the article describes ten leader retention competencies identified by TalentKeepers (building on a 20-year history of analysis work), that are vital for creating a high-retention culture. We have chosen five of these competencies (out of ten) that we believe are of extra importance for a leader.

1. Trust builder: Creates a sense of trust and concern with the team members.
2. Esteem builder: Develops ways to give team members responsibility, autonomy, the freedom to act, and to feel good about themselves.
3. Communicator: Communicates the importance of retention to team members and others effectively.
4. Talent developer and coach: Develops and coaches team members to help them grow, which results in greater commitment and loyalty to the organization.
5. Talent finder: Within the scope of his/her role, actively seeks to source and select qualified people effectively. To be able to do this the leader needs to know his/her people.

Miodonski (2005) states that there are three things that are the keys to leadership; vision, action, and spirit. The leader needs to know where the company is going and where he/she is taking the company. To take action is crucial to bring the company forward. Everyone makes mistakes because we are all human, but the important thing is to do something if problems arise. Have passion for what you do, if not, find something else to do. Success should be celebrated according to Boyens (2007). The leader should celebrate and recognize success along the way, no matter how small because success is a journey and not a final destination. This celebration will help the leader to motivate the employees. There is no need to strive to be a popular leader according to Hägglund & Larson (2003). The leader must however always be respected, then he/she gradually will be popular.

The leader's role involves in most cases a certain degree of loneliness; this is part of the role. It is of importance to value and respect everyone equally. The leader need to be aware of the fact that it is hard to be an equivalent group member, but without having an affected distance to the employees (Larson & Hägglund, 2003). A leader constantly needs to make decisions that involve employees they have an intense relation with, which creates distance. They cannot count on getting support from an employee when a decision is affecting them negatively. It is important for the leader to find strength when conflicts are created (Capotondi, 2002). There need to be some sort of distance between the leader and the employee. According to Eberhard & Vibits (2004), an important aspect in the relation between the leader and the employees is the reliability. To be able to cooperate there need to be trust. To be a trustworthy leader there cannot be any special treatment of certain employees. To appear as an objective and neutral person in the managerial work is of decisive importance.

### **2.3.2 Leadership and understanding**

A central conclusion in Sandberg's doctoral thesis *Human competence at work* (1994), is that competence is not represented as a set of knowledge and skills. The results of the study show that a human's knowledge and skills proceeds of, and is based on the person's comprehension of her/his work. The person will within the frame of her comprehension develop the knowledge and skills she is using in her working performance. In that way becomes competence development utmost a question about changing the prevailing understanding of work towards one that is better in a qualitative

way. The worker develops her knowledge in every new task she performs. Sandberg & Targama (1998) states that when a leader affects the comprehension/understanding of the employees work, they also affect the competence that is developed in the organization. Comprehension is the ground for learning at work. Learning at work is intimately related to competence, because learning is about development and maintaining competence. Competence at work consists of a specific set of characteristics, as knowledge and skills humans possess in relation to a certain job.

The latest years developments in the society has gone from a detailed control form of leadership, towards a leadership based on ideas and visions, which creates a common understanding among the employees according to Sandberg & Targama (1998). It is a matter of increasing people's freedom of action in order to release their capability. According to Sandberg & Targama (1998) the leader need to influence people's comprehension in order to make them manage the working tasks in a way which strengthen the organizations competitive advantage and give results. It is important for the employee to choose the right leader says Hägglund & Larson (2003). The "right" leader does not keep information and knowledge to him-/ herself, instead the employee's competence increase and steadily grow through the job. Employees will get the freedom they deserve and do not feel a need to change jobs, but thinking about taking the next step within the company. Continuously Hägglund & Larson (2003) believe that having the "wrong" leader is the biggest cause for dissatisfaction and ill health in an organization.

The "new" doctrine means a break with several established concepts about the basic problems within management. For example, how companies can be successful in competition with others, what it takes for people to get involved and to do their best, and how an organization should be organized and led to be affective in the long-term. The doctrine, leadership based on understanding, advocates increased local freedom. A leader will always have a line of formal tasks which traditionally belong to the leader's role, where the "new" doctrine is focused on the communicative tasks. The management needs to make the employees make their own judgements, and take own decisions as far as possible. This demands the leaders to have confidence in their employees and to commit in development of competence. Accordingly this requires engagement and involvement from the employees (Sandberg & Targama, 1998). Instead of managing the organization in detail, system and routines should work as broad frames for the organization. Within these frames, there are grades of freedom which employees are expected to use and in the best possible way satisfy customer demand. At the same time should quality be increased and costs watched over.

### **2.3.3 A consultative leadership**

The central leadership tasks are to guide and stimulate people in the ongoing process in the organization. In a leadership based on understanding, the leadership character becomes more consultative, it is about encourage, guide, and support of employees according to Sandberg & Targama (1998).

The most fundamental task for the company management that has a leadership based on understanding is to affect the employees understanding of their own, as well as the company's work. For the leader to be successful he/she needs to developed skills to handle understanding. The leader should in order to reach this task, read and map out humans understanding of essential occurrences at work. The leader can then take this as a

starting point in efforts for the purpose to influence this understanding. There need to be awareness from the leader that people in the organization is confronted with, and take part in new train of thoughts, methods, and approaches. Functioning processes should be developed, where people can present and work on experiences and ideas, and in that way develop an understanding. Methods that can stimulate engagement and involvement should be found, these methods gives the necessary driving force to question and review one's understanding.

These tasks demand a new kind of conduct for the tasks and competence in using new methods and instruments. Sandberg & Targama (1998) states that a consultative leadership can be seen as painful because the leader has got the responsibility for the organizations results, but lack full control over the mechanisms which can contribute to achieve a good result. This kind of leadership also puts more pressure on the employees as they get more independent and get more responsibility in their work. Taking own responsibility, and a feeling of freedom, will motivate the employees to perform better.

The leader will have to trust that their employee's judgements are productive considering the management's ambitions. According to the increased freedom of the operative employees, the leaders have become more dependent of influencing people's comprehension of their work and the surrounding world. Sandberg & Targama (1998) explains further that the comprehension constitutes the base for people's actions within organizations. It is important to develop and to maintain a common comprehension among the employees about the company's task. The performance will be more effective if everyone strive towards the same goal. The ability to analyse and to handle uncertainty is an important competence in the contemporary and future leadership according to Lind Nilsson & Gustavsson (2006). In order to make decisions regarding adjustments in the organization and to perform relevant change, it becomes an important task for the leader.

### **2.3.4 Communication theories**

According to Lind Nilsson & Gustavsson (2006) is communication the main tool for leadership practices and the cohesion factor in organizations. The leadership is a relation between the leader and the employees. To show mutual understanding, honesty, and respect will build good relations. Communication and information within the organization where everyone is participating is crucial and employees need to be involved.

Tengblad (2003) states that the employees need to feel that they have time and strength to take responsibility and to actively show interest in the organization. Continuously, Tengblad says that there has to be sustainable development in the organization. Many employees experience stress and inability to engagement because of an increased work load in combination with frequent organizational changes and unclear managerial structures. A significant number of employees have problems with abnormal fatigue, difficulties to sleep, and problems to relax from work in their spare time. A work load which is too high will lead to a decreased organizational ability of development (Tengblad, 2003).

In order to have a well functioning organization the key is to communicate, especially in times of changes. To continually communicate what the problems could be, what the desired future is, and also how the employees will benefit from possible changes

(Boyens, 2007). Boyens states that nine-tenths of all problems with managing people stem from poor communication, therefore proactive communication becomes important. Of great importance is also how the message is being delivered in order to avoid misunderstandings and rumors. Leaders and managers need to provide proactive, consistent, and clear communication to succeed. The biggest prevention of good communication is poor listening.

### 2.3.5 Communication models

The classical communication theories are based on four different pillars; sender, message, channel, and receiver. Shannon and Weavers “Mathematical Theory of Communication” from 1949, is general recognized and one of the most important theories regarding communication (Fiske, 1997). Communication is seen like transference of messages, as in the school of process. Shannon & Weavers model focus on which logical theoretical demands an information system need to fulfill in order to transfer a message from one source to another according to Hård af Segerstad (2002). The reason for the leader to choose this model is supported by its comprehensiveness and simplicity, and that the model is used in various research of communication. It is a well established model which still is frequently used in today’s literature within the subject.

An information source is the first stage in the model and symbolizes the person who is sending the message. After the person has selected the message which will be sent, the process enters its second phase, the transmitter. The message is being transformed to a signal from the sender, which is sent through the channel to the receiver. A telephone can for example represent both sender and receiver, where the telephone cable is the channel between the two. The item which is not in line with the model is the noise source. The noise source is added or disappears after the sender has sent the message through the channel and before it reaches the receiver. The destination is the person from whom the message is intended (Shannon & Weaver, 1949: 4-6).

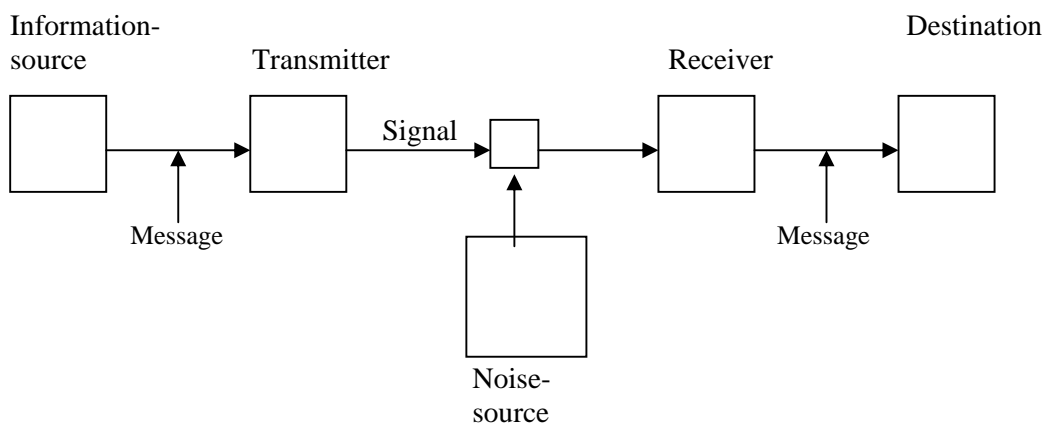

Fig. 1: Schematic diagram of a general communication system (Shannon & Weaver, 1949: 5)

The model has had a significant penetration and still has leverage. However, the model had to endure criticism as it just looks at the message way to the receiver, and no way on how the receiver interprets the message. According to Heide et al (2005) the problem is that communication appear to be something simple, and this simplicity can create a certain superstitious belief on the own system of communication.



### **2.3.6 Feed-back**

Feed-back is according to Fiske (2007) the transference of the receivers reaction back to the sender. Feed-back makes it possible for the speaker to adapt his/her description to the need and response from the audience. Some channels of communication complicate the process of feed-back substantially. The face-to-face communication is preferable when information is given between an employer and an employee.

The main function with feed-back is to help the communicator to adapt the message to the receivers need and response. Feed-back helps the receiver to feel involved in the communication. To know that the communicator respect the receiver's reaction makes him/her more inclined to accept the message. If the receiver is incapable of expressing a reaction of the message, this can lead to a growing feeling of powerlessness which can lead to so much distraction that the message goes completely lost (Fiske, 2007).

Feed-back is necessary for development and change. When sending and receiving feed-back there are some factors that should be taken into consideration according to Tullberg (2007).

#### **Sender**

- Address changeable phenomena
- Clear I-messages
- Address behaviour
- Describe – do not judge
- Be specific – give examples
- Choose privacy and right time

#### **Receiver**

The receiver of the feed-back goes through different stages, the defence stage, the explanation stage and the listening stage. The listening stage needs to be reach in order to take in the message given from the sender.

The defence stage –denial, suppression, aggression, regression, projection

The explanation stage –Yes, but, because

The listening stage –valuating, testing, understand

(Tullberg, 2007-02-15, Lecture in Human Resource Management)

### **2.3.7 Organizational structure**

Even though managers have the right values and a will to make changes in the organization it can be difficult because of a certain organizational structure. These leaders are not necessarily free to build new structures according to Wallgren et al (2006:5). Wallgren et al (2006) believe that leaders continually struggle to work and to understand this complexity. Leaders need to work with existing organizational structures and management models, and also how they can simplify the complexity. Complexity concerns the numbers of elements in a surrounding and the differences they show according to Hatch (1997).

## 2.4 Summary of chosen theories

The following theories were chosen to be the base in our theoretical framework. In order to facilitate the reading of our analysis and conclusion, we would like to highlight some theoretical aspects.

### - Retention management

The reasons why employees voluntarily leave organizations are many, in accordance with Mitchell et al (2001), people often leave for reasons unrelated to their jobs. In order for companies to retain their employees, they need to investigate the cause of turnover.

### - Key employees

McGregor's theory X and theory Y gives the reader a view of how successful management depends upon the ability to predict and control human behaviour, and how motivation of employees are influenced in relation to the management's practice. It is important to recruit key employees that are motivated, in order to keep them.

### - Good leadership

A leader needs to be able to lead himself/herself in order to lead others, regarding to Lind Nilsson & Gustavsson (2006). People need to feel like their contributions to the organization are valued (Taylor, 2001). To keep good people involved in the company, leadership is important regarding Miodonski (2005), because employees want to be part of the game.

On the basis of the theory we have come to the conclusion of the following model. The model has been compiled on the basis of our own understanding, and findings regarding the theories. The figure shows that the most important matter of retention management according to the theories are leadership skills, followed by communication, challenges, rewarding and benefits, and finally work environment.



Fig. 2: Compiled model regarding the theories

### 3. Methodology

---

*The thesis methodology is based on a qualitative study where the company Tradeka has been researched. The aim of this chapter is to clarify and explain the chosen methodology. First, there is a compilation of chosen resources, and an explanation on how the gathered material will be analysed. Finally, the content of the practical methodology, as well as a motivation and presentation of chosen respondents will be made.*

---

Important for the structure of the investigation is the choice of method. The goal with the thesis is that the reader will be able to accept the results and the conclusions of the study. The academic structure needs to be clear in order for the reader to follow the investigations course of events, discussion and argumentation (Rienecker, 2002). When writing a thesis it is important to choose a method on the basis of the problem formulation and to consistently stick to the method as to not complicate the work. The investigation is based on a qualitative study, but where the thesis empirical findings will be compared with the theoretical framework.

The most important way of treating the language when writing a thesis is, according to Rienecker (2002) to investigate. In order to be objective and scientific when writing the thesis there are a number of ways of treating the language that supports the thesis itself. Apart from investigating, the thesis should also argue, motivate, prove, discuss, interpret, and evaluate.

#### 3.1 A qualitative study

To handle questions in social science, qualitative and quantitative methods are being used according to Holme and Solvang (1997) in the book *Research Methodology*. Through available method tools which continuously develop, the possibilities increase to make bigger and better studies. A qualitative method should be used in a study when a phenomenon is being investigated. Qualitative interviews give a deeper and more detailed understanding for the chosen phenomena.

The qualitative interview is developed from unstructured question techniques. The interview is characterized by a conversation where the respondents are being guided in the smallest possible way (Andersen, 1998). Merriam (1994) explains further that qualitative interviews assume that individual respondents define their reality in different ways. During the interviews, which are partly structured, certain information is gathered from the respondents. The interviews are controlled by a quantity of questions; however the expression and order are not defined in advance. This interview type makes it possible for the researcher to develop the situation in pace with new ideas gathered from the respondent as they emerge. This type of unstructured interview is useful when the researcher does not know enough about the phenomena to ask direct questions.

The advantage with the qualitative interview is according to Kvale (1997), its openness. The interview investigation is an open form of interview and has therefore no direct rules or standard techniques that need to be satisfied. It is possible to see the process as a conversation where the researcher gathers the relevant information for the investigation. Therefore, the information gets individual and varied answers depending on the

respondents. This also helps to illustrate how important it is to choose and conduct the interview with the right respondent. The “human factor” needs to be taken into consideration when this type of method is being used according to Holme and Solvang (1997).

Our qualitative study is based on interviews in the case company Tradeka. We have interviewed six supervisors and five employees in total. The interviews were approximately 45 minutes to one hour long. The interviews were conducted in the meeting rooms, at Tradeka’s office in Tampere, Finland. All interviews were face-to-face interviews between the respondent, and the interviewer. Because of geographical reasons, only Maria was there to interview, and the language was Finnish. Before the interviews, all respondents received our interview guides personally, in paper form. Maria presented the subject of the thesis to potential respondents, and then booked interviews with interested respondents. Our questions were based on the theoretical aspects of the thesis. A tape recorder was used during the interviews, which might have affected the respondent’s answers, but to get all important information, we chose to use the tape record.

### ***3.2 Empirical findings***

The main goal is to get a deeper understanding of a phenomenon in the organization Tradeka. The chosen phenomenon that will be investigated is: how Tradeka works with retention management, and what leaders in Tradeka do to keep their key employees. On the basis of the problem formulation, and the purpose of the study, an adequate method was chosen, in form of a qualitative study.

The reason for choosing the Finnish company Tradeka as our research company and specifically the financial department is because of previous work experience, and personal contact in the company. Interviews will just be made at the financial department of Tradeka which consists of approximately 100 people, with five supervisors that are responsible for 20 employees each, and one financial manager that are responsible for the whole department.

A normal organization structure, like the one we might work in, in the future increased our interest in the company. Previous experience from working in Tradeka might help us to get a deeper understanding of what we will find out from our research. Some finding may be obvious for a person with previous experience and it can be hard to think critically. We are still going to be able to see the research in different approaches as we have different knowledge backgrounds and cultural differences. Our own discussions will therefore be helpful and it is also an opportunity for the research to have Maria, as a Finnish insider, to explain the Finnish way of work with human resource management.

Tradeka’s financial department is a good size for us to base our research on, which helps us in our type of research. Sample sizes were large enough to get valid results as the numbers of leaders were of a good amount of our research - five team-supervisors, and one financial manager, over approximately 100 employees. The six supervisors and the five employees that were our respondents were positive towards being interviewed which facilitated our research.

### **3.3 Data processing - Primary and secondary sources**

The aim for the interviews was to have knowledge about the organization and the subject so that the conversation could hold a relevant level of knowledge. According to Banaka (1971) there are different logical levels during a conversation. During the interview should the interviewer and the respondent strive to be on the same knowledge level in order to bring the interview to the next relevant level.

The primary sources consist of the interview material. The secondary sources that have been used are scientific literature and articles which concern the chosen theories. Research has been made through the use of different databases, such as Jstor, and Gunda (library catalogue of Göteborg University). Keywords that have been used can be seen in the abstract of the thesis.

#### **3.3.1 Interview in practice**

Kvale (1997) states, that the respondent has a personal relation to the subject and makes a personal statement. The interviewer should during the whole interview be observant on latent reasons of statements. It might be a will by the respondent to say “the right things” which will lead to an incorrect description given. In the same way that literature resources are controlled a critical review of oral resources should be made also. Authentic tendency, addiction and distance are factors that should be included when reviewing oral resources.

Kvale (1997: 85) divides the interview process into seven interview stages which facilitate planning and gives a comprehensive picture of the course of events. The *composition* is the foundation for the investigation, the purpose is formulated and the subject which shall be reviewed is described. The next step is *planning*, on the basis of a subject the seven different stages are prepared. Reflections around the moral aspects which touch the investigation should even be considered here. The *conduction* of the interview should be made according to an interview template. It is important not to stress through an interview, but to reflect over the information that has been given. After asking for permission, a tape recorder has been used during the interviews to control that the right information has been worked on. Recording will be for transcription purposes only and the respondents have been asked to be as open as they like during the interview.

The *print-out* is the step between interviews and analyse. The gathered information is prepared before being *analysed*. When the choice of analysis method is being made, the choice should be grounded in the purpose, subject and the character of the interview material of the investigation. The next paragraph is to *verify* the interview result. The final stage in Kvale’s interview stages is the *report* where consideration to scientific criteria and ethical aspects should be taken. Finally, the results of the investigation are compiled.

#### **3.3.2 Description and motivation of chosen respondents**

All supervisors at Tradeka’s financial department has been interviewed, the financial manager, responsible for the whole department, and the five team-supervisors, responsible for 20 employees in teams. The finance department is divided into five teams, with approximately 100 employees. To get valid and truthful answers we interviewed five employees from these teams, to get their view on similar questions from other

approaches, and also to get a broader view at the phenomenon retention management, even if our research perspective is the leader's actions. This leads us to eleven respondents in total. To get truthful answers we have chosen to keep the respondents anonymity.

Each one of the team-supervisors is responsible for their own department, accounting, bookkeeping, salary management, accounts receivable, or accounts payable. The interviewed employees have been working within different departments in Tradeka. We have chosen our employee respondents throughout different criteria's. They were chosen depending on which department they worked in, background, and time in the company. We strived to get such a wide range of respondents as possible. The interviewed supervisors have been working within Tradeka between 41 and eleven years, while the interviewed employees have been working in Trakeda between 20 and one year. Our respondents are mainly woman because of the company's diverse.

### ***3.4 Criticism***

Both printed and verbal sources have been used in the project. All sources have been analysed to make use of the best quality of information. The information from the organization might lack objectivity and must therefore be critically tested. Printed literature has to the degree it has been possible been taken from its resource of origin. We are also aware of articles from newspapers, and unknown authors from academically articles might not be as trustworthy.

Our investigation could have been broader if we also investigated people that already had left their work place, but the size of this project did not give room for any deeper studies. The investigation was narrowed down by focusing on the leader's perspective of retention management. A few employees were also interviewed in order to get a slightly broader perspective of the chosen subject.

# 4. Empirical findings

*The empirical part consists of topical information about practical relations which will support those explanations and decisions that is discussed in the theory. The case company Tradeka will be presented to give the reader some general information about the organization. The aim is to give the reader an idea of Tradeka’s structure in order to better understand the empirical findings. We will present our findings about supervisors, and our findings about employees, according to our interpretation of the interviews.*

We have conducted all our interviews in Tradeka Financial department in Tampere, Finland. All Tradeka's financial services have been centralized in Tampere. The organization chart presents Tradeka’s organization (fig. 3). The interviews focus on people who are working in the financial department. In this department there are approximately 100 employees and five team-supervisors. There is also one finance manager who is responsible for the whole department. The teams work in sectors: accounting, bookkeeping, salary management, accounts receivable, and accounts payable.

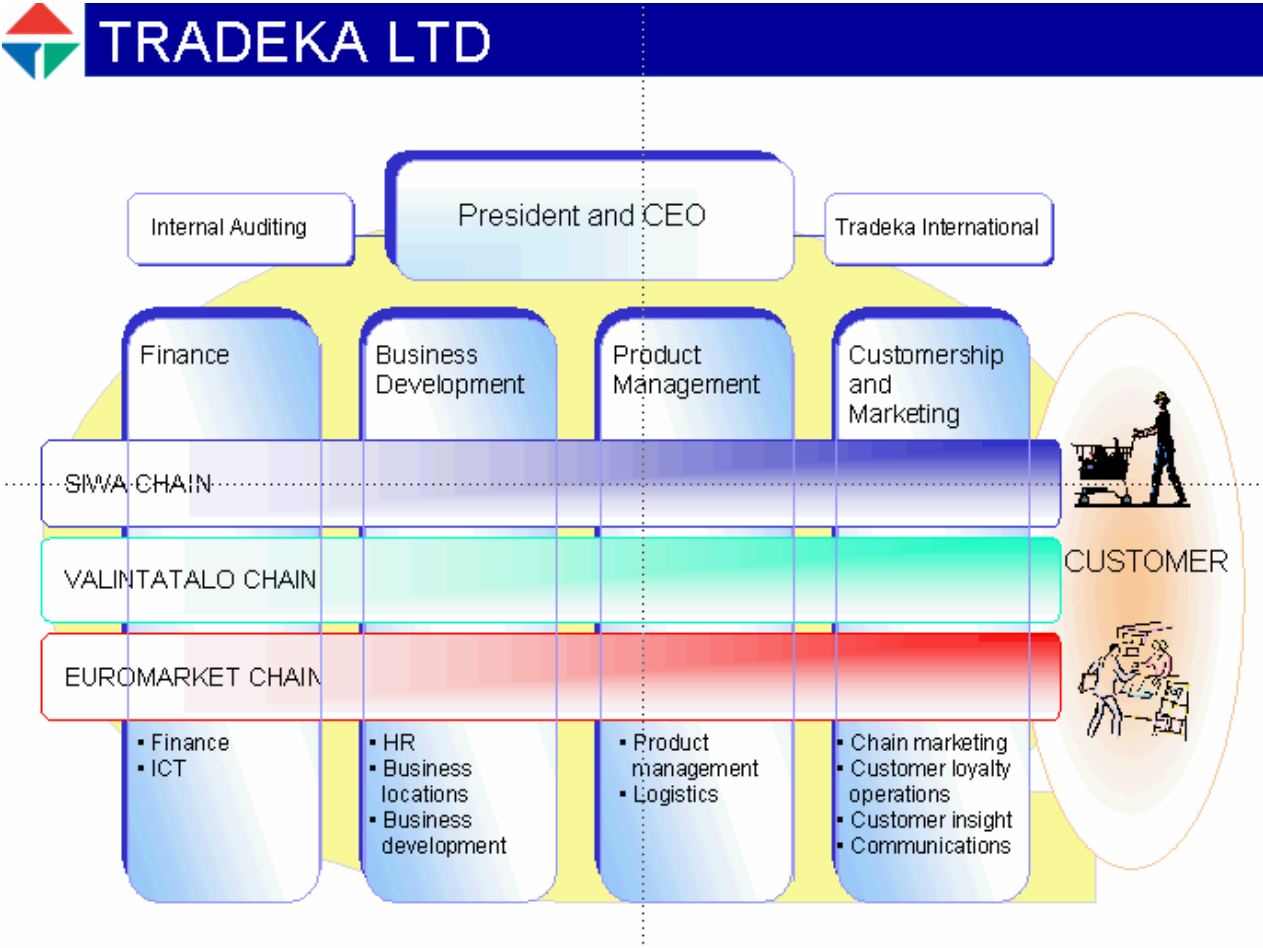

Fig. 3: Tradeka’s organization chart. (Tradeka Ltd, 2007 B)

As our research company is Finnish, we would shortly like to introduce some Finnish culture, organization structure and some differences between Sweden and Finland. These are our own general thoughts, based on our own knowledge. The aim of this introduction is to help our readers to get a better understanding of the empirical findings. We have

found a few obvious differences between the two cultures. Finnish people do not communicate as broadly as Swedish people. Furthermore, Finnish people are usually silent, they listening carefully, but they seldom say their opinion out loudly. Decision making can be seen as more effective than in a Swedish environment. Discussions do not take time, even if it could be reasonable to pay attention to everyone's opinion. Finnish leaders take responsibility in their decisions, they do not make excuses or hand over the problem to someone else. In Sweden it is more popular than in Finland to work in teams it is not so common with co-operation between co-workers in Finland, because people are more individual than in Sweden. It is easy to discuss with Finnish and Swedish leader's in general, because the organizations are mostly flat, and the communication flows horizontally. Have in mind that this is just general thoughts and differ variously between different people, and even companies.

#### **4.1 History**

Tradeka Corporation's predecessor, Osuustukkukauppa (OTK), was founded on 1917. The founders consisted of regional retail co-operatives whose number totalled 128 at its maximum. In 1983, these retail co-operatives and OTK merged to become the nationwide E-osuuskunta Eka that was later renamed Osuuskunta Eka-yhtymä (Cooperative Eka Corporation). In 1993, Eka Corporation ended up in a financial restructuring programme, with the remaining core businesses including retailing and the hotel and restaurant business. Consequently, the corporation was renamed Cooperative Tradeka Corporation after its main business area, the retail business. The financial restructuring programme was completed at the end of 2003. Tradeka Ltd is a young company with a long tradition in the retail business. Tradeka Ltd's operations were launched on January 1, 2005, when Tradeka Corporation's retail chains and chain management were transferred to the newly-formed company (Tradeka Ltd, 2007 C; Tradeka Ltd, 2007 D).

#### **4.2 Chains**

Euromarket is a hypermarket for ordinary Finnish households which are located in selected major cities. Euromarket offering all products those households needs most, daily groceries, clothing, household goods, and equipment for leisure activities. The number of outlets across Finland totals 26. Siwa has become the leader in the neighborhood shop market during the last 25 years, such a reputation requiring an outstanding operation. Siwa is a success throughout Finland, not only in the countryside but also in the heart of cities and suburban districts. Siwa's chain is growing on an ongoing basis with its total 540 outlets. Valintatalo has been popular in cities and among urbanites. It is an urban grocery shop with an individual character, as evidenced by customer appreciation, marketing awards, positive feed-back given to personnel and of course key sales figures. The number of outlets is in total 183. (Tradeka Ltd, 2007 E; Tradeka Ltd, 2007 F; Tradeka Ltd, 2007 G).



### **4.3 Our findings from supervisors**

A presentation of our empirical findings from our respondents will be divided into seven themes: History of voluntary turnover, leader's role, communication and understanding, challenges, recruitment, difficulties with retention management, and improvement of retention management. The last theme, improvement of retention management will present empirical findings, as well as a short discussion. Six supervisors have been interviewed, including the financial manager of Tradeka's financial department. For the reason that five out of our six respondents are female, we will sometimes refer to the supervisor as her or she.

#### **4.3.1 History of voluntary turnover**

One supervisor says: *"Historically the organization consisted of 34 cooperative stores which formed Eka concern. A single financial office was set up in Tampere in 1983. In those days Tradeka could not keep their employees"*. Retention history has undergone many different phases.

According to all respondents there has been a successful history in retention management. Although they have lost a couple of workers, the employer is satisfied that the employees usually stay long with the company. This situation is good from the employer's point of view. Two of the six supervisors had the same opinion that people nowadays are moving and geographically changing their work places many times, which has an effect on how long people stay in their jobs. People have moved more and more during the last years because moving is freer than before. The higher educational standards have also had an effect on retention management, and it is difficult to keep highly educated people.

Three of the six supervisors thought have not noticed that there have been any changes in retention, and that the retention is good. *"Of course there is natural turnover, but if we think about the company's size I think that the small number of people leaving voluntarily is normal."* According to one supervisor employees in general have stayed, but recently the situation has changed. One supervisor could not say what the consequence of the general employment situation was, or the reason why employees have stayed in the company. She feels that things will change though, because younger people change jobs more often. One supervisor thought that the size of the company's has created job security. She has noticed that a generational change is taking place, and that people do not expect jobs for life nowadays.

All respondents described Tradeka financial department's history of retention management as good, because Tradeka has had long-term employees. Although the financial department has lost one to five employees during the last five years, depending on different departments.

#### **4.3.2 Leader's role**

One supervisor says: *"Leaders role is important to employee retention and a leader can influence if employees remain with the company"*. The supervisor's task is to implement company policy and create best possible work conditions respecting legal rights and responsibilities. The working environment should be so good that each employee wants

to come to work every day. Work division and conditions should be as good as possible. One supervisor continues: *“Sometimes it is hard to know what leader's good characteristics are, but a leader has to get along with other people”*. Negotiation and social skills are important. For example if a mistake has been made, you cannot shout, you have to sort out the situation tactfully and constructively with the employee. The leader's role is to motivate and to give clear instructions. Different things motivate different people so a leader has to take this into consideration. Employees need to know how to act, expectations, and have a good connection with colleagues and their work. Leaders should try to do the job as comprehensively as possible even if it is mostly routine work. Tradeka's retention management policy is to offer long-term contracts and to use short-term contracts only with holiday workers and substitutes. Normally if both parties agree, contracts can be extended.

One supervisor says: *“Leader's role in retention management is to be flexible, informative, able to talk things over, to be open and approachable as well as guarantee equality, impartiality and fairness”*. She also feels that a leader's role in retention management is important, but her own role is of little significance. She points out that she is not a department leader, only a team leader, and that she just feels like another worker with no influence on retention policy in her department.

One supervisor would like to stimulate motivated and enthusiastic employees with varied work tasks, as part of their career development. She believes that it could be one of the reasons for employees to stay in the organization. She feels that there are no incentives to make the employees to stay. For example there are no bonuses.

Supervisor's most important characteristic is to treat employees fairly. Supervisor has to know what kind of job that is the best to different people. The leader has to be capable to organize work. Continuously she said that she cannot use these characteristics in her job, because she feels that her position is equal comparing to the other employees. Leader's role in retention management is to enrich employees' jobs according to one supervisor. Leader's most important characteristics are to treat employees with consideration and to be objective. Leaders should respect employees' opinions. Leaders should develop their leadership skills to be able to manage and supervise their employees in a constructive and considerate manner. Leaders should be able to retain their most valued and irreplaceable employees by offering them to enhance their jobs.

According to one supervisor leaders should be open for discussions, embrace new ideas and share her/his knowledge. The organization should have a clear structure and employees should know how to work, what for, and when. A skillful leader gets along with other people, she/he has to be a good listener and has to value other people's opinions. One supervisor thought that leader's skills come through experience and professional development.

Leaders should give responsibility to employees whenever it is possible. Every employee is important and the leader's role is to make people feel important. Leaders should observe all situations. One supervisor said: *“Leaders should make sure that the work is equally and fairly distributed, and that no one should feel over loaded with work”*. Supervisors can influence general work atmosphere in a supportive way. One supervisor feels that these are the tools which she can use to keep the key employees in the company.

Another supervisor had the opinion that the leader's role in retention management is meaningful. However, she feels that the reasons for employees leaving from Tradeka's financial department have not been caused by the leader's actions. The leader should organize work as well as possible, and share tasks as equally as possible. She/he should consider employee's knowledge, make work environment more comfortable, and create equal opportunities for all employees. The biggest challenge is to make work reasonable so that employees do not feel that work is too stressful. New technology can be a wonderful thing, but the company should not change the working methods all the time.

According to one supervisor, the most important thing in retention management is: *"The leader has to be able to deal with both positive and negative situations. She/he has to be up-front and be able to speak his/her mind. Leaders have to be honest with his/her employees."* Supervisor's also needs support from their own managers. If a leader does not know what to do, it has a negative impact on their job. Management is difficult without instructions and guidelines. Another supervisor thought that leader's most important characteristics are to be objective, have a good knowledge of human nature, and to make employees feel secure.

Another had the opinion that leader's most important characteristics are listening skills and treating people equally. To trust workers with responsibility and treating them well makes it easier to keep the key employees. If a leader asks for something to be done, she should have the authority to implement it. One supervisor would work with these issues, if she has time. Lack of money, power, and resources make the supervisor's work harder.

One supervisor feels that a leader's most important role in retention management is to increase employees' job satisfaction and to offer different work tasks. A leader should respect the employees' personal lives and see employees as human beings, and not only as employees. A supervisor should distribute work equally. She should appreciate the work accomplishes and value the employees. This could be achieved by giving feed-back so that the employees feel their importance in the work society. She mentions that she has a high level of authority and she is quite strict. She recognizes that the employees do not always like that, especially not when they get extra work and they do not have much time. Her opinion is that strict actions are needed for her team to succeed in beating the deadlines in order to do the job as effectively as possible.

Another important characteristic is an ability to organize because everything has to work. A leader should divide work as equally as possible and give responsibility to the employees. Employees need suitable work, not too much or too little. A leader has to treat everyone equally, and be able to support every employee. New work assignments can be seen as positive challenges. Some employees appreciate new tasks and responsibilities, while others can feel stressed.

All respondents have said that they have had problems with information management. They have not had all the information needed. They should also communicate better than before and to discuss more openly. An open policy should be the aim. All these things depend on the organization's culture. Information should flow freely between employees and leaders at all time, and leaders should be able to give feed-back. All respondents thought that not everyone gives or receives feed-back. Four of the six supervisors have same opinion that there are no special tools to keep the employees in the company for

example Tradeka should develop a more motivating salary policy. There are no reward systems for employees, but some of the respondents thought that it would be useful. For example Tradeka does not reward employees for loyalty. Some supervisor feels that leaders cannot organize special offers to keep their employees.

### **4.3.3 Communication and understanding**

Tradeka's aim is to have an open communication and all respondents' mentions that they should be better when it comes to communication. All respondents said that Tradeka's general communication is not open. A couple of supervisors said that it has never been. Even if some of the respondents describes that the current situation between supervisors and employees in Tradeka's financial department is satisfactory, they have mentioned that the general communication atmosphere is not in a satisfactory level.

The whole department has one meeting per month and the teams have one meeting every two months. Supervisors have to organize a team meeting once a month, but this has not happened. One supervisor says that there is no need for frequent meetings. The majority of the respondents communicate with other employees when needed. One supervisor point out that monthly and weekly meeting has not been organized, due to lack of time. The conversations are often informal and some of the supervisors also use email. One of the supervisor's points out that emails also can create difficulties, for example, the message must be clear, so that every employee will be able to understand the message in the same way, and that everyone should get the information.

Feed-back is given very seldom according to four of the six supervisors. All respondents describes that feed-back is given when needed, and they give it directly to their team-members and employees. Two of the six supervisors mentions that the supervisor would also like to get more feed-back. One supervisor says that she would like to know about her own performance. She mentions that leaders and employees also need to talk about negative things. One supervisor would like to have one-to-one discussions, because she feels that people do not dare to say what they think in groups. It would be easier to give and receive feed-back between two people. Supervisors and employees deal with new things that arise in the department immediately. If the situation is okay there are no discussions, but when something negative arises, they have to sort out the problem. One supervisor feels that it is especially hard to give negative feed-back. She feels that feed-back should be given immediately, or at least as soon as possible and confidentially.

According to all respondents they do not have annual collaborations dialogs. One supervisor mentions that they do not have time to organize them and that they do not have tools and procedures in place. Another supervisor said that she does not know what the consequences would be if they organized annual appraisals.

According to one supervisor communication networks work very well, if the employees take the initiative. People are different and act differently and some employees come to discuss their work more often than others. She is available to her employees by walking around, and communicates mostly in an informal way. One supervisor mentions that they do not have any problems with communications and understanding, because she has made it easy for the workers to come and speak with her. They can communicate in all areas. Another respondent believes in continuous evaluation, and as a result she feels that she has a better understanding of her workforce.

#### **4.3.4 Challenges**

One supervisor says: *“We can only offer employees limited challenges, because our projects depend on the whole organizations projects”*. The financial department does not have their own projects. When they get new challenges they apply the best employees. In future the amount of projects will increase, which is why supervisors are in project training.

One supervisor has not been able to offer new challenges to the employees. Tradeka does not offer training to all employees, and normally only supervisors take part in training projects, not ordinary workers. Employees meet challenges of different tasks, because everybody has to be multi-skilled in the department, as they are each others substitutes.

The majority of the supervisors mention that they have an opportunity to offer new challenges when it is needed, but it depends on the current work situation. One supervisor can offer new challenges and opportunities even if work is mostly routine. They can vary different tasks by dividing assignments differently. Work rotation can be used, but it has to be a long-term commitment, because learning a new task takes about six months. One of the supervisor interfere in the prevailing conditions by asking employees, if they need more work tasks, or if they are over loaded.

Another had the opinion that she can offer new challenges to employees, because she can influence how the work task is divided and given. She mentions that some employees do not want to, or are unable to do every assignment. Others are more keen and willing. She admits that she cannot offer enough challenges, because work assignments are what they are.

#### **4.3.5 Recruitment**

The whole organization Tradeka recruits employees with job advertisements and through the internet, except the financial department. According to one supervisor, the financial department does not advertise, and formal applications are not used. According to two supervisors, Tradeka's finance department is not attracting employees in today's job market. People do not even know that they have such a large office in Tampere. Tradeka is the third largest trade company in the marketplace, but she feels that people have little knowledge and respect for the company. Tradeka is not a pioneer and they cannot offer employees something new and interesting. She feels that the company is a little bit old fashioned. Two supervisors said that people hear about the vacancies from each other, and employees have found the finance department themselves. It is common that employees first start in summer jobs, and then they continue. In the recruitment process, applicant's standard of education has to be considered. Overqualified candidates not tend to stay. According to two supervisors Tradeka uses employment agencies. One supervisor says: *“We have only one person who is responsible for recruitment”*.

Another supervisor said that Tradeka attracts applicants by using intranet and by using an employment agency. If they notice a potential new employee they give positive feedback, which is a popular way to retain employees in the long-term. Some supervisors mention that they would like to be part of the recruitment process, because they know their team assignments and can answer applicant's questions, as well as they would like to be part of the decision making process.

#### **4.3.6 Difficulties with retention management**

All respondents claim that the Tradeka financial department has no problems with retention management. At the same time one supervisor says: "*In the future they will meet new challenges.*" Thus, constant expectations for increased productivity have brought up problems.

One supervisor feels that people do not want to have jobs for life nowadays. As a consequence, employers' recruitment practices have changed. If an employee has decided to leave, he/she leaves, mentions one supervisor. The reason for leaving has very often been a geographical matter. The supervisors feel that the reason for leaving has not been due to leadership skills or work conditions. It can be problematic situation when they find a potential person and there are no vacancies. This is often the case with summer substitutes, they would like to keep them, but they do not have a job to offer. One problem with retention management is that the salaries are determined in accordance with the trade union tables and the company cannot use wages to increase competitiveness.

One supervisor says that if she notices that the employee's natural turnover has increased, she tries to control the situation from the start. The leaders should pay more attention to employee's general satisfaction and work conditions. The group of supervisor's and the workers should discuss together in order to find out why they are thinking about leaving, if the reasons are personal, or have something to do with the company. One supervisor continues that if employee's natural turnovers increase, a dialogue about the issue has to be initiated immediately. The leader should think if she/he has done something wrong, and if the workers are leaving as a consequence. The leader should recognize her own weaknesses, and find out ways to improve her performance.

A job vacancy should be filled as soon as possible, otherwise further problems may develop according to one of the supervisors. The company should train newcomers as soon, and as well as possible. Leaders have to make sure that this does not burden other employees. Newcomers need training and the more experienced workers have to train them, so extra recourses are needed. Natural turnover can be a positive thing, if the level stays low. Problems can arise, when new computers and software are introduced. Some older employees can find the new tools more difficult to use. In the past some have even been stressed of the new machines.

The organization does no longer appoint employees directly. Some supervisor thought that the use of employment agencies has brought up some problems. Some supervisor would like to interview applicants. Employment agencies are a useable method, if they need help quickly, but it does not work in the long-term. The use of short-term agency workers puts strain on permanent personnel as they are constantly training newcomers. Permanent workers are over loaded with work, because they give training all the time. If employees have too much work, the consequences will be psychological and physical. On the other hand Tradeka has had substitutes with potential, and after the substitute period they have been employed on long-term contracts.

### 4.3.7 Improvement of retention management

One supervisor mentions that Tradeka could be better at retention management if the salaries were higher, but the rates are set by employers and trade unions collective bargaining system. All respondents describes that they could be better if they can reward employees more often than today, and a reward policy should be part of the company's policy. They should reform their salary system to be able to reward and motivate. One supervisor feels that Tradeka's financial department could be better at retention management, if they could offer more incentives. Another supervisor had the opinion that Tradeka could be better at retention management because it could motivate employees to do a better job.

Tradeka should also consider offering welfare services and personnel benefits, such as gym facilities and social functions, including parties to employees. Work environment and conditions should be improved. General work satisfaction could be better as well as work atmosphere. Employees' resources should be considered more carefully and more attention should be paid to employee's welfare. Work loads should be well managed so that employees can handle it and when it is needed they should appoint more personnel. The physical environment could be better, for example should the desks be adjustable and computers should be faster.

The company should consider employees more than they do now. One supervisor said: *"I have that kind of feeling that employees have been forgotten"*.

One supervisor thinks that Tradeka would be better at retention management if they used annual appraisals and communicated more with employees. Tradeka should offer more training opportunities. They should consider peoples professional skills and make it possible to give education. She also mentions that Tradeka's finance department has a lot of work to do regarding their communication skills, as she feels that there is not enough information available.

One supervisor said that Tradeka could be better at retention management if it was a more interesting company. Tradeka should offer career opportunities, so that employees can develop their skills and get education. The company should market job vacancies more effectively. Tradeka should be a company that applicants fight to work for. The finance department should invest more in employee's benefits. They should organize more meetings and develop information strategies. Supervisors also need support from the upper management. When discussing the work conditions, one supervisor mentioned that there is an ongoing problem with cleanliness. The out-contracted cleaning services have not been good, and they would prefer to have their own cleaner in the office.

## Conclusion of interviews

On the basis of our interviews we have come to the conclusion of the following model (like the one that can be seen in the end of the theoretical framework). The model has been compiled on the basis of our own understanding and empirical findings about the supervisors. Figure four present the most important matters for retention management according to the findings about supervisors. The most important matter of retention management is rewarding and benefits, followed by communication, work environment, challenges, and finally leadership skills.

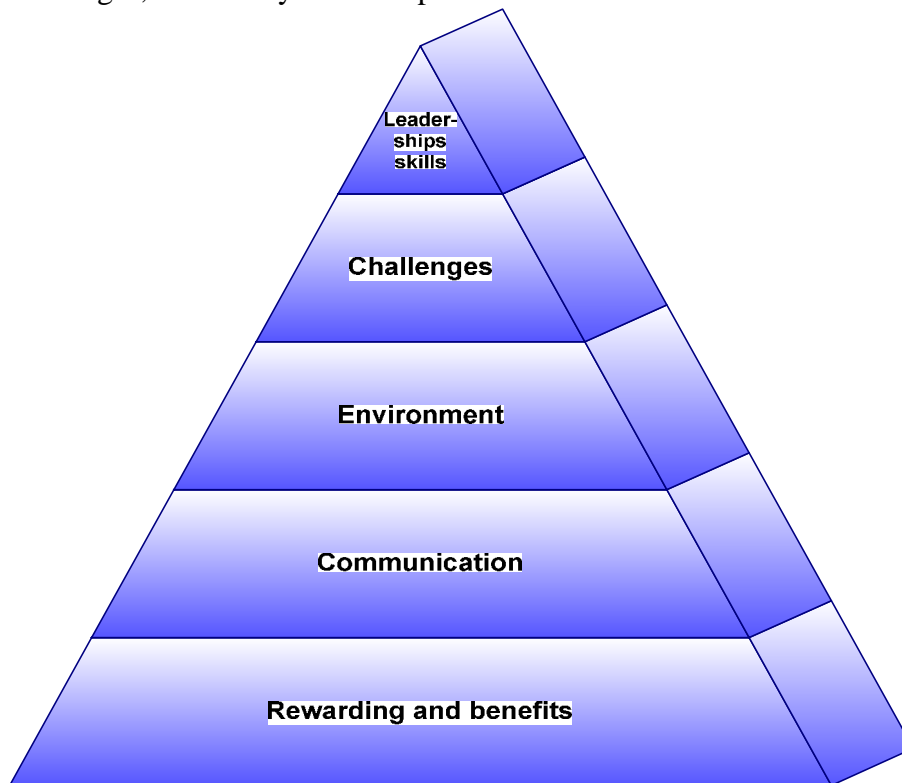

Fig. 4: Compiled analyze model about supervisors

### 4.4 Our findings from employees

A presentation of our empirical findings from our respondents will be divided into four themes: Leader's role, communication and understanding, challenges, and improvement of retention management. The last theme, improvement of retention management will present empirical findings, as well as a short discussion. Five employees have been interviewed. All of our respondents are female, therefore we will refer to the employees as her or she. The intention to interview employee's, is to give the investigation a small insight of the employees opinions regarding the same issues.

#### 4.4.1 Leader's role

One employee mentions that the leaders should work with retention management. According to another employee, leaders would keep their key employees by giving more responsibility and feed-back. They should encourage employees, and give them more challenges in assignments. One employee thought that leader's role in retention management is to manage employee's tasks, so that they match current skills. The



company should offer training because of changes. Leaders should also keep their personnel informed.

Two of the five employees had the same opinion that leaders should appreciate employees more, for example they could create a more rewarding salary system. The current system does not consider employee's loyalty and the number of years they have been in the company. If a person has worked in the company more than eleven years, the wage does not increase after that. One employee wonders if a financial bonus system would motivate employees to do their best. Another employee says: *"Leader's role in retention management is to give positive feed-back, and it would be nice to get it as often as negative feed-back"*. A leader should support and inspire employees, and it would be nice to be appreciated when doing a good job. According to one employee, leaders should be more considerable towards their colleagues.

A few of the employees mention that their work environment could be better with adjustable desks, general cleanliness, tools, and machines. Another employee also says that there should be more recreational services.

One employee mentions that she like her job and is motivated, her colleagues are nice, and also the people in the stores she is working towards are friendly. Positive feed-back from the stores employees motivates her. Another employee continues that she is motivated because of her friendly colleagues, and that she has succeeded in her job. The reason that she has stayed in her job is that she has been involved with many changes during her career. She has had the opportunity to develop and improve new skills. One employee thought that job security and regular working hours have motivated her in her job. The job matches her education, and she has been able to work for different teams and she receives a regular salary. One employee describes that she is an ambitious person and wants to do her job as well as possible, she is very motivated and she feels that the work itself is motivating.

#### **4.4.2 Communication and understanding**

One employee says that their leader's communications skills are satisfactory. They communicate daily, but they do not get the information from the upper management as well as they should. Despite of this, four of the five respondents feel that they do not have any difficulties in understanding each other. Another had the opinion that sometimes it is hard to understand what the leader says, because of the professional jargon which it is not so established by the employees. All respondents ask questions if they had problems with understanding.

Two of the five employees had the same opinion that leaders communicate when necessary, but all respondents thought that leaders do not hold formal meetings or annual appraisals. One employee mentions that leaders do not communicate with her, and that there is no communication between them. Leaders inform when there are new things that might be implemented in the department but that is quite minor. One employee mentions that at the end of the week, formal discussions are easier, because the work is less busy and people have lower stress levels.

Leaders should keep their workforce better informed, for examples, if the leader has training, the employees need to know that he/she is absent. This can create difficulties if someone needs help or advice.

#### **4.4.3 Challenges**

Supervisors have not offered any new challenges recently, but one employee mentions that she has progressed in her career to the highest level. Earlier she has had many challenges, because she had opportunity to work with different assignments. She is still motivated in her job, because of work enrichment. She could not imagine doing another work, because she believes that this work suits her.

Another employee had challenges and training many years ago, but now her only challenge is to train newcomers. One employee has had many challenges during her career, because she has worked in different sectors, and she has enjoyed lifelong learning. She has not worked in projects, but she feels that her working tasks are versatile. One employee has not been in the job for that long and feels that she gets new challenges every day. One employee enjoys her work, but she mentions that there are not any new challenges, she says that *“Work itself is variable, and you have to remember a lot of details”*.

#### **4.4.4 Improvement of retention management**

Two of the five employees is quite satisfied with their jobs, but complains about increased stress levels and defective work equipment, for example, uncomfortable and old working areas which are not ergonomically suitable. Another employee continues that some things could be improved, for example general cleanliness. Leaders should be more assertive, because some of the respondents have the feeling that leaders are too distant.

The rest of the respondents thought that they are satisfied with the current job. Reasons are friendly co-workers and success. One employee thinks that the work atmosphere is good. The only negative point is that she needs more challenges in her job. On the other hand one employee is not satisfied because the work is getting busier and conditions are getting worse, for example, the standard of cleaning is poor.

Her experience is that leaders do not treat employees with consideration and they are not rewarded, for example a party to celebrate success. She would like to get more encouragement and to have more meetings. The leaders have promised to have monthly meetings, but it has not happened. Meetings support and increase the team spirit. Another employee continues that the leaders could inform much better than they do today, and all employees should get the information at the same time.

One employee says that if she leaves her job, she will leave because of poor salary and in search for something better. Another employee will look for something more challenging, and a job that gives her a better salary. The general opinion was that the respondents could imagine leaving the current job to look for something better, for example something more challenging with a better salary. Another employee could leave her job according to a plan, for example if she wants more social achievement and contacts with people.

Another problem is uncertainty about the future. The finance department's employees do not know if their office will stay or move somewhere else, because they have heard rumours. When employees do not know what will happen in the future, they will start looking for new jobs.

**Conclusion of interviews**

On the basis of our interviews we have come to the conclusion of the following model (like the one that can be seen in the end of the theoretical framework, and after the findings about the supervisors). The model has been compiled on the basis of our own understanding and empirical findings about the employees. Figure four present the most important matters for retention management according to the findings about employees. The most important matter of retention management is work environment, followed by rewarding and benefits, communication, challenges, and finally leadership skills.



Fig. 5: Compiled analyse model about employees

## 5. Analysis

---

*This part will connect the theoretical framework and empirical findings. The headings of the chapter will be divided into the same themes that could be found in the empirical findings. The purpose of the research is to investigate the leader's actions intended for retention management. We will together analyze findings about the supervisors and the employees within our research company Tradeka. The findings will be compared with the theoretical framework and the "weak links" that can be found between theory and reality will be discussed.*

---

### 5.1 History of voluntary turnover

According to Tradeka financial department they have had a positive history in retention management and voluntary turnover. Out of 100 employees, only 13 have left the company over the last five years. Even though they have had a positive outcome there have not been any special efforts in trying to keep employees, as retention plans etc. In order to develop a retention plan, the leader must investigate several on-the-job and off-the-job factors, and select those which are the most applicable to the firm (Mitchell et al, 2001). Because of the "positive" situation Tradeka has not been forced to make any changes. The majority of supervisors have not seen any problems with retention management, but some supervisors have noticed that people are leaving and newcomers and young people are appreciated and somewhat necessary.

We are hoping for a changing phase in Tradeka and their view of retention management. If they do not concentrate on retention management at the moment they might run into big difficulties in the future as it is necessary to see this issue in a long-term perspective. According to Boyens (2007), the effect of voluntary turnover includes loss of performance, knowledge, expertise, relationship, and loss of the time and resources that it took to train the employee. The company needs retention structures that make sure they have a diverse work force, with employees of all ages and gender. Maternity leave and retirement are examples that need to be taken into consideration. Even though they say that voluntary turnover is not a big problem for them, it might cause them troubles in the future. There can be natural reasons for voluntary turnover which force them to implement retention plans. According to the supervisors voluntary turnover is a positive thing, as long as it happens in small quantities. They have to remember that some changes are possibilities for renewal. There is a weak link between the theories of voluntary turnover and Tradeka's opinion. It has not been a priority for Tradeka because they have not seen voluntary turnover as a problem in the organization. To be more aware that this problem can arise in the future will help the company to prevent such an outcome.

The system of using an employment service agency has been useful in the short-term as substitutes. If these temporary employees perform well there have been a chance for further or a permanent employment. Some supervisors have noticed that it has caused problems by using this type of recruitment. The "old" employees get overloaded with working tasks, as they at the same time need to train new employees. Proper mentoring requires an investment from the company itself. For a period of time there will basically be two employees doing the same job (McCrea, 2007). The working atmosphere will improve and teams will get more stabilized, if it is possible to keep temporary employees the company is happy with. All employees need to take responsibility over their own

working area. Substitutes might not put in as much effort as other employees, because they know that the job is just temporary. Temporary or part-time workers usually quit after working for some specific amount of money. Dissatisfaction is not the cause and there is no search for alternatives (Mitchell et al, 2001).

There is a need of thinking of recruitment in the long-term and what kind of actions Tradeka has to implement to become better in the future. Termination needs to be a natural part of the recruitment process as people retire and leave the company of other reasons. Tools that can be used in this process will be for example retention plans, welfare services or rewarding systems.

Tradeka needs to be aware of the reasons why employees have stayed with the company, in order to use retention management better in the future. To do this properly they can take advantage of old employees, general work situation, interesting job or atmosphere. They need to concentrate on who has left, and the reasons why, and then determine if the company and its leaders are the reason the employees decided to leave. The future situation will be different because of younger employees and the different views they have about staying in one job, or finding a better job. The generation today makes the situation different regarding the work force according to Alch (2000).

It would be helpful for Tradeka to implement retention plans because plenty of old employees leave because of retirement. Many employees feel that they are overloaded with work tasks and that they are stressed about the work situation. This might eventually lead to job hoping. Supervisors need to focus on employee retention, if they want their employees to stay in the organization.

## **5.2 Leader's role**

The supervisors agree on many important leadership roles. Leaders have a big responsibility to motivate and to give clear instructions. The leaders need to know his/her employees in order to give them challenges they are able to handle, because people are different. Employees want a leader who knows them, understands them, care, concern, treats them fairly, and is someone whom they can trust. Retention management and retending employees is about relationships according to Taylor (2001). Some people need challenges in order to perform better, while other people are happy with the current situation and find motivation in routine. The leader needs to create a safe work environment and comfortable atmosphere were the employees will not hesitate to communicate with supervisors and other employees if problems arise. There should be an open communication flow within the whole organization and leaders have to be open in most situations. Therefore, it is important for the leader to be a good communicator and listener. The supervisors have to share her/his knowledge. The "right" leader does not keep information and knowledge to him-/ herself (Hägglund & Larson, 2003). The differences in the theory about an open communication within companies, and the empirical findings can be due to a different organizational culture in the Finnish society. Finnish people are in general quite silent, they listen carefully and seldom say their opinion out loudly, but of course this differs between people. The overall opinion is that Finnish leader's take responsibility in their decisions, and that they do not make excuses.

Social skills of the leader are also of importance if complications arise and they must be capable to handle employees, show empathy and understanding for employee's personal

life and working life. Supervisors do not need to like everyone, but they need to be objective and to treat everyone fairly, respect all employees and see them as members of your professional family (Boyens, 2007).

Feed-back is of big importance to both parts. Almost all respondents have said that feed-back needs to be improved and increased. Lack of feed-back could be one reason for the communication problems. The employees and supervisors need to know if they are doing a good job or not, and how they can be better. Employees need support and clear instructions from the leaders. The employee's knowledge and skills will progress if he/she has comprehension of her/his work. Sandberg & Targama (1998) states that when a leader affects the comprehension/understanding of the employees work, they also affect the competence that is developed in the organization. Comprehension is the ground for learning at work. If the leader offer varied work task the motivation will improve. The leader's in Tradeka try to offer their employees challenges in their work, if requested, as far as it is possible.

To have good negotiation skills as a leader is something that is of crucial importance both to the supervisors and the employees. The leaders need to be able to negotiate both positive and negative matters. They cannot be afraid to face any kind of situations. The leader cannot avoid conflicts and they need to be honest towards supervisors and employees. Flexibility is also a characteristic that supervisors believe to be important in a leader. They need to be open and adjust easily to new situations. Acceptance goes hand in hand with flexibility, and this shows that leaders need to be open to change.

The management should put a lot of effort into increasing employee job satisfaction because of the correlation between satisfaction and productivity (Wallgren et al, 2006). The supervisors should offer the employees education and updates on current topics. That shows that investing in their employees is one of their most important recourses. We believe that training and education will lead to job enrichment and the motivation will increase. The employee will get the feeling that the company is willing to commit to the employee and involve them in the future plan of the organization. This undertaking will encourage the employees to become more motivated and productive in their job.

Work conditions need to be as comfortable as possible for the employees. If their working area is not clean and ergonomic enough this will eventually lead to low work performance and sickness. If the work condition is not at a satisfying level the employees will feel even more stress then before (Mitchell et al, 2001 & Boyens 2007). Generally employees will get affected both physically and mentally. If working conditions are not ergonomic the employee's necks or backs will suffer pain. The company will in the end suffer from absent workers because of these matters. Bad work conditions will mentally affect the employees and make them develop a "bad" feeling about work. Tradeka could improve their working conditions by investing in more comfortable working areas and cleaner facilities, as there has been dissatisfaction regarding these issues. We think that Tradeka needs to consider their employees as their first priority, as they are their most important resource (McCrea, 2007).

Some of the supervisors agree that important leadership characteristics are to be: objective and a good organizer. Authority and respect for the leader is necessary, according to two of the supervisors, in order for employees to do their job according to the schedule. The tasks need to be divided in order for the employees to be responsible

for their own work. In order for the leader to be effective he/she needs to have the ability to delegate and provide the employees with the necessary tools to perform their jobs. Supervisors need to delegate responsibility so that employee motivation will rise to a higher level.

It is one thing to say something, but harder to act according to what we know is right. According to the supervisors there are many ideal characteristics of a leader but they can be hard to live up to. It is necessary to be aware of, and to continuously work with these issues. Lack of time, money and tools makes it hard for the supervisors at Tradeka to improve leadership skills. To continue to be a profitable company, and to grow, they need to focus on what is important and sustainable. There is no need to make excuses for these issues as they might arise and become even bigger problems in the future.

### ***5.3 Communication and understanding***

Tradeka financial department has obviously had some problems with communication. All eleven respondents said that Tradeka generally does not have an open communication atmosphere. Generally supervisors and employees believe that communication only works well between supervisor and employee. While the communication higher up in the organization seems to be less satisfying. All respondents say that the communication in the organization is not open because they are not communicating within the whole organization. Employees and supervisors do not get informed about general matters, such as changes that influence the organization. The supervisors need to be available to employees as there have been situations where supervisors are absent and employees do not have anywhere to go if problems arise. According to Lind Nilsson & Gustavsson (2006) is communication the main tool for leadership practices and the cohesion factor in organizations. The leadership is a relation between the leader and the employees. To show mutual understanding, honesty, and respect will build good relations. There is a weak link between the theory and the empirical findings because of an open communication are not seen in the whole organization.

Communication is more informal than formal between the supervisors and employees. Here they communicate between each other when necessary and just when problems occur. According to the supervisors this situation is due to lack of time and the tools and support for proper communication is not available. A renewal might help the organization towards a change that will make them be more profitable in the long-term. To make this matter take a new turn, we believe that the company's management needs to become more aware of this problem and look for possibilities to make changes.

Annual appraisal dialogues are something that does not exist in the financial department of Tradeka. These dialogues are an opportunity for both supervisors and employees to give and receive feedback. The main function with feedback according to Fiske (2007) is to help the communicator to adapt the message to the receivers need and response. Feedback helps the receiver to feel involved in the communication. If you do not get to the chance to hear what you can do better in the future, or what has been working well, it will be hard to improve working tasks. It is easier for employees to meet personal goals and for supervisors to delegate tasks if there is an understanding. Trust that occurs from these meetings will be appreciated between the two parts as people open up and do not feel fear when speaking their minds.

Feed-back systems need to be implemented as well as appraisal dialogues. Obviously this is not working at the moment. All respondents mentioned that they would like to get feed-back on their work. In the current situation feed-back is given when needed, which is not enough. Tradeka needs to see the possibilities that these dialogues can increase the communication and make the atmosphere more open. Employees will then feel taken care of and that their opinions matter. One of the supervisors mentioned that it can be hard to give negative feed-back. According to Tullberg (2007), is feed-back necessary for development and change. A supervisor cannot be afraid to face an employee, whether he/she comes with negative or positive feed-back. Currently feed-back is mostly given when the message is negative. It will be easier to give negative feed-back if positive feed-back is also given. When giving feed-back, the sender of the message needs to be clear, describe the situation, not judge, be specific and give examples. Feed-back should also be given in privacy and at an appropriate time. The receiver has to be at the listening level so that he/she can value, testify and understand the message. The listening stage needs to be reached in order to take in the message given from the sender according to Tullberg (2007). Education and training should be offered to supervisors so that an open communication will increase. Appraisal dialogues should be used as well as feed-back systems. The possibility to give feed-back and to use appraisal dialogues will need training and education. Supervisors have to be capable to give feed-back.

We believe that frequent meetings are necessary. At the moment the financial department of Tradeka usually has discussions when new things or problems arise. A weekly group meeting is demanded where both issues that have been working well, as well as things that need to be done differently are discussed. Everyone should have their say and listen to what other people have to say. New ideas will be considered and a greater understanding between employees and supervisors will be created. According to Sandberg & Targama (1998) and their view of a consultative leadership, which is based on understanding, the leadership character becomes more consultative, it is about encourage, guide, and support of employees. Tradeka is seen as a democratic organization, with democratic values and where it should be possible for employees to take more responsibility, but at the same time they are fighting against an organizational structure with clear frames.

Organization culture is something that plays a big role in the communication and understanding of the organization. Communication has been working in the same way over many years and it can take some time to implement new ideas. Therefore, it is important that both supervisors and employees push new implementations forward in order to get a positive change. Changes that might be necessary could be a more modern organizational culture, where new leadership styles are implemented.

The organization need to put more focus on their human resources instead of a task oriented leadership style. There needs to be a good balance between the two, as the company also needs to produce good results, but human resources and profitability go hand in hand. The work-force today is changing and greater leadership skills are demanded. It is the rights of human beings to have a working environment that make the employees feel comfortable at their job. Lack of communication could be one reason for voluntary turnover and for Tradeka's key employees to stay in the company they need to put more effort into this issue.



## **5.4 Challenges**

The majority of the supervisors believe that there are possibilities to give challenges to the employees, while one of the supervisors says it is not. These challenges are usually in form of getting more and different tasks at other teams, instead of climbing higher inside the department. Therefore challenges are limited. The employees are able to do different assignments and to rotate between the tasks. New work assignments can sometimes be created in the form of projects or implementing new working methods (software programs etc.). The financial department developing of projects depends on the development needs in the whole organization. Supervisors mostly take part in these projects, and the key employees might have the opportunity to get involved.

Challenges are usually limited in a financial department because of the working tasks and assignments. Due to the law, the tasks need to be in certain ways and they cannot be changed or varied. Tradeka's financial department has five different teams and their work tasks are divided through approximately 100 employees. Because of the size of Tradeka's financial department, the work assignments are divided between the employees, where for example one person is responsible for salary payments. Employees want to be part of continuously educational training, as they can teach newcomers and implement new software.

Currently employees do not get any education, but throughout the years there have been education due to changes. Team supervisors get project education and English courses, because projects will increase in the future and English might be the corporate language. While implementing education there need to be clear directives and information on why, and how, the education will affect, and improve activities in the company.

## **5.5 Recruitment**

The majority of the supervisors considered themselves not having any influence in the recruitment process and they do not feel that they have any responsibility. Today there is one person responsible for the recruitment process and in the future some supervisors want to play a bigger part in the process. According to Capotondi (2002) it is important to think in the long-term when it comes to recruitment, find the right employees, recruit them, and motivate them to stay in the company. The recruitment process would be more efficient if the team's supervisor take part in the recruitment. Supervisors have a responsibility to let applicants know what to expect. In the future the main responsibility might be on one person, but that supervisors are also part of the process. If supervisors take part of recruitment processes they can meet applicants and see if the person is capable to work in her/his team, if there is a "match". The recruitment process should be a responsibility for the main responsible person, as well as the supervisor.

Tradeka financial department, need to market themselves in a better way. Many people in Tampere do not even know that this big company exists. To use an employment agency is currently common within Tradeka and they do not have a direct formal application form. New employers mostly find the company by themselves and take contact in an informal way by contacting the company. Tradeka also use the intranet in order to contact Tradeka's employees, which opens opportunities for internal work positions. They need to attract employees on their own and not just use employment agencies if they need personnel in the long-term. It might be easier to know if the applicant is really interested in the position and if there is a good match between employee, organization and work

duties. To meet the applicant in person before employment is of great importance even if they have a probationary employment. If applicants apply directly they might be more loyal as they get paid directly from Tradeka and write a contract between the organization and the applicant. Even though employment agencies are common nowadays, Tradeka should have a more direct contact with potential employees, as this might help them to find more motivated and loyal personnel. Boëthius & Ehdin (1993) believes that people who has committed development into themselves, and who creates good results, does not need someone else to motivate them. To be motivated it is crucial to follow the conviction and the want to perform well, because that is what creates meaning at work. The leader's task is to give the employees the conditions to find the conviction. The weak link between the empirical findings and the theory might decrease if Tradeka's recruitment process becomes in style with what they believe in.

Tradeka have to consider applicants desires, age, previous work experience, willingness for long-term employment, and right level of educational background. The organization need a diverse work force and people that fit into the organization. People with an educational level which is too high will not be motivated and productive. This might influence other peoples working performances as well.

## ***5.6 Difficulties with retention management***

All supervisors in the financial department of Tradeka do not believe they have any difficulties with retention management and to retain their employees. This might be the situation today, but we have noticed that problems might arise in the future. According to one supervisor, the reason for people to leave has not been disappointment in management skills or work environment. The supervisors mentioned that reasons for leaving the company have been geographical matters. This might not be true according to reality. Another supervisor says that leaving the company is due to lack of challenges, or the desire of a higher salary. Other reasons for leaving the company can be a higher stress level and overworked employees. As we have heard, failure in their working atmosphere can be the cause of people leaving the company in the future if this matter does not improve. Awareness of voluntary turnover, and the reasons for people leaving, needs to be considered. One supervisor says that a small amount of voluntary turnover is positive because people enter and re-enter and termination should be a natural process. Newcomers bring new ideas and young people are often open to changes.

Difficulties for the organization to retain their employees can according to the supervisors be that they do not have much to offer their key employees. Even if employees say that they appreciate long-term contracts and a safe future in their job. Salary is paid according to trade union tables so wages cannot be a competitive weapon for the financial department.

An employment agency works in the short-term as a substitute but Tradeka need to plan ahead and hire employees for the long-term. One of the better ways is to recruit persons directly, and meet them in person, but this is not always possible because of lack of time. Most of the supervisors are concerned of the problem with recruitment systems and the problems they are causing to retain their employees. Some employees think it is their responsibility to introduce new employees into the work task, but at the same time they feel overworked. If the teaching process continues like this, it might lead to loss of employees. Newcomers need to be taken care of in the best possible way.

Dissatisfaction among the employees might eventually lead to employees leaving the company and that is a risk that Tradeka financial department not can afford to risk. The employees need to feel safe in their work environment, and a better communication and open information will prevent rumours to be spread in the company. If employees do not get clear information about the future, they feel uncertain and will start looking for new jobs.

### **5.7 Improvement of retention management**

All respondents believe that retention of employees might improve if higher salaries and bonus wage systems are implemented. This will make employees more motivated, productive and they will be more profitable if they perform at a higher level. Rewarding systems would improve the retention management, such as bonus, commission, benefits, incentives, continuing education opportunities, vacation time and retirement plans. Boëthius & Ehdin (1993) mean that the external motivation gives the possibility to push from behind, and at the same time entice from the front with rewards, but his motivation will increase the expectations of bigger rewards. Support and visibility from leaders are necessary in order to have a well working organization management. To be motivated, Boëthius & Ehdin (1993) says that it is crucial to follow the conviction and the want to perform well, because that is what creates meaning at work. The leader's task is to give the employees the conditions to find the conviction.

“Small” benefits such as gym card, “special” Friday coffee break, and Christmas parties can make a big difference to the employees and it does not have to cost a fortune. It will mean a lot to the employees and give them the feeling of being appreciated. At the same time the leader shows that the employees are important to the company and his/her attitude towards the employees will increase. Improvement in the company's job satisfaction and culture can be made through creating a positive work environment according to Boyens (2007). Make the employees be a part of the organization and show that their presence matters. Both supervisors and employees mentioned that they need to be better taken cared of. They had a feeling that employees have been “forgotten”.

In order for the supervisors to get respect, the employees should be well treated. Personal and professional growth opportunities, recognition and implementation of some of their ideas will show the organizations concern about their employees. McGregor (1960) means that managers must have the right conception of employee's motivation in order to increase their effectiveness. Successful management depends significantly upon the ability to predict and control human behaviour. Requirements of job duties should be clearly defined, as well as realistic goals and expectations. According to the supervisors, job enrichment will boost employee retention. Work environment and work conditions can be improved through an agreement with a well organized cleaning firm or if Tradeka have their own cleaners. High technology and new software that make the working tasks more effective will raise the feeling of a good work condition. An ergonomic work environment will make the employees work more effective, prevent working injuries and will decrease sick leaves. All companies wish for their employees to be present and to physically feel good at work. Employees might feel stress due to an increasing working pace, which results in overworked and sick employees.

Communication and information is the main issue Tradeka need to develop. Communication in form of open dialogues and discussions as well as annual appraisal

dialogues will help to give and get feed-back. Information meetings where general information is given and where everyone gets the possibility to change ideas is crucial for an open atmosphere. If employees do not know what will happen in the future they will apply for new jobs, therefore communication and information is especially important.

*“You must know where you are going and where you are taking the company”*  
(Miodonski, 2005: 12)

To keep employees in the company they need to feel part of the organization as mentioned earlier. People need to feel like their contributions to the organization are valued (Taylor, 2001). Being part of the professional family and to share company values will make employees more committed and more interested to stay in the organization. Make employees more interested in the company through internal presentations that can lead to better marketing of the company and attraction of new employees. Better marketing of the financial department through different channels such as newspapers, exhibitions, internet, and collaborations with financial students should be implemented.

Tradeka’s employees are happy with their co-workers and the working atmosphere. It is important to know that this atmosphere might decrease if key employees decide to leave. If employees have problems with other issues the good working atmosphere might be damaged.

Employees appreciate flexible working hours because this allow them to take responsibility over their own working hours, and give them more opportunities to plan their personal life. For employees to make their own judgements, and take own decisions, it demands the leaders to have confidence in their employees (Sandberg & Targama, 1998). Employees at Tradeka personally feel that their working tasks are interesting, even if they are more stressful than before. Positive matters like the ones mentioned above, help Tradeka in their retention management. They need to take advantage, and use the positive effects to retain their old employees and to attract new employees.

## 6. Conclusion

---

*The conclusion of the thesis will be presented in “What we have learned”, where results and learning’s on how to improve retention management will be made. The thesis research questions will be answered, with help of the empirical findings together with the theories. A summary of our observations throughout the study will be presented, as well as recommendations for future studies.*

---

The purpose of the study was to investigate and to analyse how company leaders in our research company Tradeka can retain their key employees through retention management. Another aim of the study was to establish a sense of a procedure that leaders can apply to retain employees. During the study we have been concentrating on the leaders perspective, but to get a more valid result of the study and a deeper understanding of the phenomena retention management, we also decided to interview a couple of employees. Even if employees have been interviewed, our focus of our conclusion will be put on the perspective of the leader.

A leader’s perspective was chosen to narrow down the investigation, because of the size of the thesis. The interest in this subject started to grow as we have seen a change in today’s workforce, as well as previous research’s gave us the idea. Retention management is something that is important for everyone, small as well as big, new, and old organizations and branches. The subject might play a bigger role in the future which made us want to learn more about the phenomena and what can be made in order to overcome this issue for leader’s and companies.

### 6.1 What we have learned

Throughout the investigation we have increased our knowledge in retention management and the understanding of what an important role leadership plays in order to have a well working retention management. To conclude the empirical and theoretical findings we are confident to say that leadership skills and communication plays a major role. The investigation has been very instructive and our knowledge about this phenomenon has improved.

- **Retention management**

Why is retention management so important? During this investigation we have learned that retention management might be a bigger issue then we first realized. Our interest for the research started with interesting articles that described todays and future issues that might affect retention management. Special interest was seen in a changing workforce, the Net generation, and how organizations can gain from retention management in practice.

It lays many things behind retention management, and the investigation has opened our eyes for how this issue can come to grow in the future. Retention management might be hard for companies to handle if they do not think in a long-term perspective. We have learned from the investigation that focus on long-term planning becomes important. The company and the leaders should put in a great effort to hire the right employees, as it gets more and more important to find the “perfect match”. When the right employees are

hired, the company must work hard to retain their employees. A long-term perspective has been mentioned many times in the investigating, because companies need to try to predict the future as it can be too late to hire people in an economic upswing.

Is it just motivation and rewards that keep employees in the organization, or does other things also count when retaining employees? In the beginning of the investigating we believed that motivation was one of the key issues in keeping employees in the company. Now we have learned that it takes a lot more to retain top employees, and leaders have to continuously work hard in these questions. Lots of money and knowledge will be lost if key employees decide to leave the company, which they usually cannot afford. Retention management will cost less than to lose key employees. Companies can succeed in their position towards competitors through retention management in the future. A well developed retention management can offer companies the key to success.

- **Leadership**

Leadership is about relationships. In all situations becomes trust a key characteristic for a leader according to what we have learned from the investigation. A leader that is a trust-builder will create a sense of trust with the team-members. To create this relationship between the leader and the employee, takes a lot of effort and time. The leader needs to know every employee, and know the employees goals in order to satisfy their needs. If the leader succeed in his/her relationship with the employees, the chance is greater that the employees stays in the company, and that they want to grow within the organization.

Leadership based on understanding gives the employee more responsibility and help to retain the employees, as they get more motivated. The leadership is based on ideas and visions, and creates a common understanding among the employees. This kind of leadership increases the employee's effort in understanding the working tasks, as well as the company's work. An employee's comprehension of the work will develop the knowledge and skills he/she is using in his/her working performance. For employees to be successful and grow they need to understand their work. Challenges will according to this leadership be met more easily, as independent employees will increase their responsibility, which will lead to freedom and motivation. An organizational structure that makes the company profitable will also open the possibility to commit in employees. If these two things are balanced, they will together drive the company forward.

Rewards and benefits should be implemented from the leaders, but it does not have to cost a fortune for the company. Small things as organized parties or special Friday coffee breaks, is easy to offer and will show that the employees are appreciated. The leader should celebrate and recognize success along the way, no matter how small, because success is a journey and not a final destination. This will help the employees to strive for the same goal. Salary and benefits are just a small part, employees want a leader whom they can trust, which is the key part in retention management.

- **Communication**

During this investigating it has become clear that our research company's main problem, has been an open communication atmosphere. We have learned that the communication needs to be open within the company in order for employees to trust their leaders. Without communication, it gets hard for leaders to know their employees and their needs, which eventually can lead to loss of key workers. People are different and come from different backgrounds, which make them interpret the message differently and can find different meanings in the same message.

To be an active listener is important, but it is even more important to be open to renewals, and to act in order to sort out any types of problems or situations that might arise in an organization. The leader should see the possibilities, and be able to make improved changes in connection with dialogues to employees.

In a retention management perspective, the employees should be informed what to expect in the future, information goes out to everyone involved in an open communication. If the communication is not open, it will create rumours which can be devastating for the company, as the wrong information starts to be spread.

The study shows that feed-back is needed in Tradeka, as well as appraisal dialogues. We have learned that people need to now when their performance is succeeded and appreciated, but also when their work should be improved, this regards both employees and supervisors. If positive feed-back is given it will also be easier to give/receive negative feed-back. The research shows that leaders need tools and training to develop their communication skills, and they cannot be afraid to deal with feed-back.

### **Answers to the problem formulation:**

#### **What are the consequences between leader's actions and employee's retention?**

We have learned that leaders and their skill in creating a culture of retention, has becoming a key in why people stay and what usually drives them away from a company. The leader has become the main factor in what motivates people's decision to stay or leave. For organizations to keep its key employees their number one priority should be to look at their management, because people leave managers and not companies.

During our interviews many employees mentioned that higher salaries and benefits would be a reason to leave Tradeka and move to another company. This might work as an attraction in the short-term but we have learned that people join companies for these attractions, but they leave for other reasons, like a poor management or job enrichment (challenges). The interviewed supervisors also agreed that higher salaries and benefits might help to retain employees in the company. Pay is at risk for becoming commodities, as competitors can compete with the same offers. The difficulty for Tradeka in this sense, is that they cannot use salaries to increase competitiveness because of their determined salary policy. This must push Tradeka even harder to work with retention management issue, so that they can offer their employees something they cannot find among their competitors.

### **Which is the leader's role when it comes to retaining employees?**

As our learning has taught us, leadership and communication are the mainstays for an effective retention management. We would like to point out characteristics in a leader that we believe are of extra importance, as the leader's role plays a key role in retention management: trust builder, esteem builder, communicator, talent developer and coach, and talent finder.

The leader's relation to the employees plays a central role in retaining employees, because we have learned that employees need to feel, involvement and that their presence count. It is the responsibility of the leader in the organization, or the leader for a specific department, to deliver the message about retention management to the leader's higher up in the organization. Problems that arise need to be taken seriously, and dealt with directly in the specific department, or even to the upper management.

A balance between leadership, communication, challenges, rewarding and benefits, as well as work environment have to be implemented. It does not matter if just one of these issue is well functioned, because the leaders role is to work with all of these themes in the organization. The research has taught us that leadership and communication are the most important roles for a leader to work with in retention management, as shown in our compiled model, regarding theories, supervisors, and employees. All these things together form a winning organization. When retention is a core value, good things happen for customers, employees, and the company.

## **6.2 Recommendations**

Recommendations for future studies concerning retention management, is for anyone who might be interested in the subject.

Our interest when writing this thesis lied in the perspective of the leader, in addition to the size of this project, just one perspective was chosen. This is just one of many perspectives, but further suggestions in researching this subject is to look at this issue from other perspectives. An investigation can for example be conducted on people that actually left their work place, in search for something better and more challenging.

Continuing studies in retention management that is seen from a female or male approach would have been of interest. Our respondents were mainly female, therefore it would be interesting to see if the results from the interviews would have been different from male respondents.

A study about retention management, which is made in other countries, branches, and other departments can be researched and compared. It would be appealing to see the differences and similarities.

Stress is something that would be interesting to investigate further and how stress applies to retention management. Stress is a big part of the society today and a hot topic to everyone. This problem can definitely give serious affects to society and organizations, if not taken care of.



## List of References

- Alch, M.L. (2000) Get Ready for the Net Generation. *Training and Development*, February 2000, pp. 32-34.
- Bergström, S. (2006) *Företag med framtid – Hållbara företag och hållbar utveckling*, Kristianstad: Liber AB.
- Boëthius, S. & Ehdin, M. (1993) *Myten om moroten – En syn på ledarskap och motivation*, Stockholm: Svenska Förlaget.
- Boyens, J. (2007) Employee Retention: The Key to Success. *Franchising World*, Vol 39, issue 2, p. 59-62.
- Branham, L. (2005) *The 7 hidden reasons employees leave – How to Recognize the Subtle signs and act before it's too late*, Saranac Lake, NY, USA: AMACOM.
- Capotondi, R. (2002) *Chefens bästa vän*, Stockholm: Redaktionen Stefan Ekberg AB.
- Fiske, J. (1997) *Kommunikationsteorier*, Borås: Wahlström och Widstrand.
- Hatch, M.J. (1997) *Organisationsteori – Moderna, symboliska och postmoderna perspektiv*, Lund: Studentlitteratur.
- Heide, M. (2005) *Kommunikation & organisation*, Malmö: Liber AB.
- Hislop, D. (2005) *Knowledge management in organizations*, New York: Oxford University Press.
- Holme, M. & Solvang, B. (1997) *Forskningsmetodik – Om kvantitativa och kvalitativa metoder*, Lund: Studentlitteratur.
- Hård af Segerstad, P. (2002) *Kommunikation och Information – en bok om människans förmåga att tänka, tala och förstå*, Uppsala: Uppsala Publishing House AB.
- Hägglund, U. & Larson, R. (2003) *52 steg mot toppen – The wireless organisation*, Stockholm: Ekerlids Förlag.
- Kvale, S. (1997) *Den kvalitativa forskningsintervjun*, Lund: Studentlitteratur.
- Lind Nilsson, I. & Gustafsson, L. (2006) *Ledarskapets inre och yttre resa*, Lund: Studentlitteratur.
- McCrea, B. (2001) When good employees retire. *Industrial Distribution*, March 2001, pp. 63-66.
- McGregor, D. (1960) *The human side of enterprise*, New York: McGraw-Hill
- Merriam, S. (1994) *Fallstudie som forskningsmetod*, Lund: Studentlitteratur.

Miodonski, B. (2005) Re-recruit your best employees to retain them. *Contractor Magazine*, Vol 52, issue 9, pp. 12-12, September 2005.

Mitchell, T.R., Holtom, B.C., & Lee, T.W. (2001) How to Keep Your Best Employees: Developing an Effective Retention Policy. *Academy of Management Executive*, 15 (4) :96-107.

Rienecker, L. (2002) *Att skriva en bra uppsats*, Malmö: Liber ekonomi.

Sandberg, J., & Targama, A. (1998) *Ledning och förståelse - ett kompetensperspektiv på organisationer*, Lund: Studentlitteratur.

Sandberg, J. (1994) *Human Competence at Work – An interpretative approach*, Göteborg: Grafikerna i Kungälv AB.

Scheuer, S. (2000) *Social and economic motivation at work - theories of work motivation reassessed*, Copenhagen: Copenhagen Business School Press.

Shannon, C. & Weaver, W (1949) *The Mathematical Theory of Communication*, The University of Illinois press: Urbana.

Taylor, C.R. (2002) Focus on talent. *Training and Development*, December 2002, pp. 26-31.

Tengblad, S. (2003) *Den myndige medarbetaren: strategier för konstruktivt medarbetarskap*, Malmö: Liber ekonomi.

Tradeka Ltd (2007) A

<http://www.tradeka.fi/tradeka/ipub.nsf/sivut/etusivupohjaeng?OpenDocument&cid=mainpage>  
Online 2007-04-09

Tradeka Ltd (2007) B

<http://www.tradeka.fi/tradeka/ipub.nsf/sivut/peruspohjaeng?OpenDocument&cid=organisaatioeng>  
Online 2007-04-08

Tradeka Ltd (2007) C

<http://www.tradeka.fi/tradeka/ipub.nsf/sivut/peruspohjaeng?OpenDocument&cid=YHhistoriaeng>  
Online 2007-05-25

Tradeka Ltd (2007) D

<http://www.tradeka.fi/tradeka/ipub.nsf/sivut/peruspohjaeng?OpenDocument&cid=historiaEng>  
Online 2007-05-25

Tradeka Ltd (2007) E

<http://www.tradeka.fi/tradeka/ipub.nsf/sivut/toimialapohjaeng?OpenDocument&cid=euomarketeng2>  
Online 2007-05-25

Tradeka Ltd (2007) F

<http://www.tradeka.fi/tradeka/ipub.nsf/sivut/toimialapohjaeng?OpenDocument&cid=siwaeng>  
Online 2007-05-25

Tradeka Ltd (2007) G  
<http://www.tradeka.fi/tradeka/ipub.nsf/sivut/toimialapohjaeng?OpenDocument&cid=valintata>  
loeng Online 2007-05-25

Tullberg, M. (2007) Lecture in Human Resource Management, 2007-02-15.

Young, T. (2006) Implementing a knowledge retention strategy. *Knowledge Management Review*, Vol 9, issue 5, pp. 28-33, November/December 2006.

Wallgren, L.G., Leijon, S., & Malm-Andersson, K. (2006) Managers' work motivation and their conceptions of what motivates their subordinates: A study in an IT consultancy firm.

Wikipedia (2007) A <http://en.wikipedia.org/wiki/Retention> Online 2007-05-12

Wikipedia (2007) B <http://en.wikipedia.org/wiki/Management> Online 2007-05-12

Wolmesjö, L.G. (2007) Rekrytering – en het bransch. *Göteborgs-Posten, Jobb-Studier*, pp. 1, 13th May 2007.

Author unknown (2006) The battle for brainpower - A survey of talent. *The Economist*, October 7<sup>th</sup> 2006, pp.3-5.

# Appendix 1

## *Interview guide to the supervisors*

1. What do you work with in Tradeka? (Tasks and assignments)
2. How many years have you totally worked in Tradeka and as a supervisor?
3. What kind of history do you have in retention management and in voluntary turnover? (How many employees have leaved during in the last five years?)
4. Have retention management changed in the last years? If so, how?
5. What is the leader's role when it comes to retaining employees? What is the leader's most important role in retention management?
6. What can leaders do to give their employees the best supervision?
7. How can leaders retain their most valued and irreplaceable employees?
8. How do leaders at Tradeka work in order to keep their employees? (Long-term relations, benefits)
9. What do you believe are the most important characteristics in a leader? (According to retention management?)
10. What kind of actions would you apply if an employee is considering leaving their job?
11. What kind of difficulties has Tradeka with retention management?
12. What is the current situation regarding communication and understanding between employees and leaders? How often do you communicate with your employees? Is there an open communication within Tradeka? (The lack of communication could be/are one reason to leave a job?)
13. How do you use feed-back, and how often? (So the employees will know when they are doing a good job and to know what is expected from them)
14. How often do you give new challenges and opportunities to your employees? (Annual appraisal dialogs)
15. How can organizations and leaders attract employees in today's job market? (Retention bonuses) (long-term recruitment)
16. How can Tradeka be better regarding retention management?
17. Do you consider retention management in the recruitment process? How?

## Appendix 2

### *Interview guide to the employees*

1. What do you work with in Tradeka? (Tasks and assignments)
2. How many years have you worked in Tradeka?
3. What can leaders do to keep their key employees or what do you want them to do?
4. What would be the reason for you to search for another job and/or leave your current job? (Following a plan, leaving without a plan, leaving for something better, leaving an unsatisfying job?)
5. How often do leaders communicate with you?
6. How often do you get feed-back? Do you get enough?
7. Is it hard to understand what leaders say to you, or demands from you?
8. Are you given new challenges or opportunities? What kind? What motivates you in your job?
9. Are you satisfied with your job?

***Explanation of concepts:***

**Involuntary turnover:** turnover either through termination or layoffs

**Voluntary turnover:** employees choose to leave the company on their own

**The purposes of annual interview:**

- To determine if proper use is being made of employee
- To identify employee potential
- To determine future employment, deployment.
- To review performance
- To identify training needs
- To encourage and motivate
- To improve communications, joint problem solving
- To assist merit increase decisions