



UNIVERSITY OF GOTHENBURG
SCHOOL OF BUSINESS, ECONOMICS AND LAW

Master Degree Project in Finance

Contingent Convertible Bonds
A Market-Conform Equity Derivative Model

Giulia Cesaroni

Supervisor: Martin Holmen
Graduate School
University of Gothenburg
A.Y. 2016-2017

Abstract

This thesis focuses on the pricing of the Contingent Convertible Bonds (CoCos), using the Equity Derivative approach and the Bates model to simulate the stock price with Monte Carlo algorithm. The CoCo bonds are hybrid financial instruments with loss-absorbency features, characterized by a conversion into equity or a write-down of the face value, when a specified trigger event happens, which is usually related to an accounting indicator of the bank. The Equity Derivative model prices the CoCos under the assumption of the Black-Scholes volatility, converting the accounting trigger into a market trigger. Instead, the thesis aims to underlining the impact of a more market-conform path of the stock price. Hence, the Bates model is considered more suitable in this pricing framework, allowing the stock prices to have sudden jumps and a time-varying volatility. Therefore, the comparison between the Bates and the Black-Scholes models is made within the Equity Derivative framework. The market trigger is unobservable, thus the analysis of the CoCo prices is done indirectly. Namely, matching the model prices with the observed market prices of two categories of Barclays CoCos, the levels of the implied market trigger are inferred. The higher they are, the higher trigger probabilities should be. However, while the Bates extension provides a market trigger greater than the one in the Black-Scholes case, the related trigger probabilities are lower, overturning the interpretation for which the Bates model provides a riskier valuation of the CoCos. Finally, a number of factors that impact on the model applicability are considered, showing how a complex structure of the CoCo is difficult to be captured by an implied-market approach, as the formulated extension of the Equity Derivative model.

Keywords: *Contingent Convertible Bonds, CoCos, TIER 2, Additional TIER 1, Equity Derivative Model, Bates Model, Stochastic Volatility, Implied Volatility, Jump Diffusion Process, Monte Carlo Simulation, Quadratic Exponential Scheme*

Acknowledgement

I express a deep sense of gratitude to my family for the guidance and the encouragement, during all these years. I also would like to thank Davide, who has reassured and inspired me.

I am very thankful to Stefano Herzel, for his support and to have given me the possibility to experience the Double Degree program, and to my supervisor Martin Holmen.

Contents

	Page
Abstract	I
Acknowledgement	II
List of Figures	V
List of Abbreviations	VII
1 Introduction	1
2 Understanding CoCo Bonds	4
2.1 Key Features	4
2.1.1 Loss-Absorption Mechanism	5
2.1.2 Activation Trigger	7
2.1.3 Host Instrument	9
2.2 Regulatory framework	10
3 The Pricing	12
3.1 Literature Review	12
3.2 The Equity Derivative Approach	15
3.2.1 The Black-Scholes Setting	17
3.2.2 Beyond Black and Scholes	21
4 The Bates Model for CoCo Valuation	26
4.1 Calibration	26
4.1.1 Modified Option Pricing (FFT)	27
4.2 Monte Carlo Simulations	30
4.2.1 Quadratic Exponential Scheme	31
4.2.2 Variance Reduction	33

5	Case Study: Barclays CoCos	35
5.1	The Dataset	35
5.2	Calibration Results	40
5.2.1	The Damping Factor	41
5.2.2	Implied Volatility Surface	42
5.3	Implied Barrier of the CoCos	44
5.3.1	AT1 CoCo: Case of a Full Conversion	45
5.3.2	T2 CoCo: Case of a Full Write-Down	49
5.4	Discussion of the Results	52
6	The Viability of the Bates-ED Model	54
6.1	The Simplified Context	54
6.2	The Impact of the Jumps	55
6.3	The Model Calibration	58
6.3.1	Different Approaches	63
6.4	Final Remarks	64
7	Conclusions	66
A	Appendix	67
A.1	CDS: Bootstrapping the Default Intensities	67
A.2	Other Results of the Calibrated Bates Model	68
A.3	Stock and Volatility Behaviours	70
A.4	The Milstein Scheme for the Heston Model	72
	References	75

List of Figures

2.1	Contingent Convertible Bond Features	5
2.2	Comparison of the Price of a Conventional Convertible Bond and a Contingent Convertible Bond	7
2.3	Regulatory Capital Requirements under Basel III	11
3.1	Accounting Trigger ($CET1_t$) vs. Market Trigger (S_t)	15
3.2	Example: Comparative Statics of the Equity Derivative model using the Black-Scholes Volatility	20
3.3	Effect of ρ and λ on the Volatility Smile of European Call Options with one-year maturity and an underlying stock value of 100	24
3.4	Effect of (negative) μ_J and σ_J on the Volatility Smile of European Call Options with one-year maturity and an underlying stock value of 100	25
3.5	Effect of λ_J on the Volatility Smile of European Call Options with one-year maturity and an underlying stock value of 100	25
5.1	Daily Close-Adjusted Stock Prices (GBP) and Log>Returns of Barclays PLC from 24 March 2007 to 24 March 2017	35
5.2	Q-Q Plot - Comparison of the Quantiles of the Barclays Stock Prices versus the Standard Normal Quantiles	36
5.3	Available Option Data in terms of maturity (T) and the strike price (K)	40
5.4	Calibration of the Bates model - Comparison between the Model Prices and the Market Prices	41
5.5	Implied Volatility Surface under the Bates Model with respect to different Option Classes	43
5.6	AT1 (Respectively No.1, No.2, No.3 CoCos) - Comparison between (Monte-Carlo) Bates-ED, BS-ED and Market Prices	47
5.7	Trigger Probability as Function of the Market Trigger for No.1 CoCos in the Bates-ED Model and the BS-ED Model	49
5.8	T2 CoCo No.4 and No.5 - Comparison between (Monte-Carlo) Bates-ED, BS-ED and Market Prices	50

LIST OF FIGURES

5.9	No.5a TIER 2 CoCo - Comparison between (Monte-Carlo) Bates-ED, BS-ED and Market Prices	51
6.1	T2 CoCo No.4 and No.5 - Comparison between Monte-Carlo (Heston) Equity Derivative, BS-ED and Market Prices	56
6.2	AT1 CoCo No.1 - Comparison between Monte-Carlo (Heston) Equity Derivative, BS-ED and Market Prices	57
6.3	No.1 CoCo Market Price vs. (Left) Test 1 Bates-ED Model Price; (Right) Test 2 Bates-ED Model Price	60
6.4	Volatility Skew for European Call Options w.r.t. $S^* \in [30, 78, 150]$ - (Left) Test 1 ; (Right) Test 2	62
A.1	Calibration of the Bates model w.r.t. α	69
A.2	GBM Application - Simulated Path of the Stock Price over 10 years divided into 2500 Time-Steps for one and 10^4 trials	70
A.3	QE Application - One Simulated Path of the Stock Price and its Volatility over 10 years divided into 2500 Time-Steps	71
A.4	QE Application - 10^4 Simulated Paths of the Stock Price and its Volatility over 10 years divided into 2500 Time-Steps	71

List of Abbreviations

AT1	Additional TIER 1.
Bates-ED	Equity Derivative Model with the Bates Extension.
BDI	Binary Down and In.
BS-ED	(Black-Scholes) Equity Derivative Model.
BSJ	Black and Scholes Jump.
cdf	Cumulative Distribution Function.
CDG	CDS Data Group.
CDS	Credit Default Swap.
CET1	Common Equity TIER 1.
CIR	Cox Ingersoll Ross.
EDG	Equity Data Group.
FFT	Fast Fourier Transform.
GBM	Geometric Brownian Motion.
GBP	Sterling.
GBp	Pence Sterling.
IV	Implied Volatility.
OTM	Out of The Money.
pdf	Probability Density Function.
PONV	Point Of Non Viability.
QE	Quadratic Exponential.
RWA	Risk Weighted Assets.
SV	Stochastic Volatility.
SVJ	Stochastic Volatility and Jumps.
T2	TIER 2.
USD	U.S. Dollar.
w-RMSE	Weighted-Root Mean Square Error.

1 Introduction

Contingent convertible bonds (CoCos) are hybrid instruments with loss-absorbing feature. This additional source of risk is rewarded with higher coupons than ordinary bonds. Hence, whenever the issuer would face a distress, contingent convertible bonds can be partially or fully written-down or converted into shares. The loss-absorption mechanism is linked to a specific event (trigger event), that can take several forms and usually, is expressed in terms of bank's Common Equity TIER 1 (CET 1) Ratio. When it hits the barrier level or due to the decision of the regulator (Point-Of-Non-Viability, PONV, in case of regulatory trigger), this mechanism is activated, following the conditions of the contract. In most cases, the trigger level is based on the CET 1 Ratio, that is the percentage of the bank common-equity capital with respect to the Risk-Weighted Assets (RWA), and ranges from 5% to 8% (Spiegeleer et al., 2015).

The role in the new banking regulation has been increased, especially as a consequence of the Great Financial crisis of 2007 and 2008. The financial distress required a huge intervention of the Governments to strengthen bank's capital. Hence, Avdjiev et al. (2013) argue that the use of CoCos could substitute the government intervention in times of financial troubles. Indeed, CoCos have features that satisfy regulatory capital requirements. Then, they are demanded mainly by private banks and retail investors and not by institutional investors. Finally, they have a high correlation with the CDS spreads and equity prices. According to that, the Basel Committee on Banking Supervision released a set of proposals (Basel III) in response to the financial crisis, aiming to reinforce the quality, consistency and transparency of the regulatory capital base (BIS, 2009). Under Basel III, CoCo bonds can count as bank's regulatory capital, in addition to common equity and retained earnings - being recognized as loss absorbing instruments (BIS, 2010b). This feature outlines one of the first differences with respect to ordinary bonds. Furthermore, under the Capital Requirements Directives (CRD IV, 2013) CoCos can reach the volume of 1.5% of the Risk Weighted Assets for the Additional TIER 1 (AT1), while for TIER 2 they can account for 2% of the RWA, that are respectively the core capital and the supplementary capital. The new regulatory framework has developed even more their use, with a market volume of over € 120bn in the latest years (Spiegeleer et al., 2015).

Due to the rising importance of these hybrid financial instruments and the fact that

1. Introduction

they have a nature in between equity and debt, several pricing models have been implemented. In particular, using the assumption of a constant volatility of the stock price, the Equity Derivative model (Spiegeleer and Schoutens, 2012a) prices the CoCo bonds as a combination of several derivatives. The trigger is linked to the event of the share price hitting a barrier, called market trigger. Using this approach, my analysis is applied to the prices of both the fully converted and the fully written-down CoCo bonds, denominated in USD and available on the market on the 24th March 2017 for Barclays PLC. Then, the Equity Derivative model is extended using the Bates model (Bates, 1996), which includes a stochastic volatility and jumps of the stock prices. Due to the lack of a closed formula of the model under the stochastic volatility assumption, Monte Carlo simulations are used to draw the stock price and its volatility, using a Quadratic Exponential scheme for the time discretization and evaluating the trigger event for each CoCo bond. The aim is to understand the impact of the jumps and a non-constant volatility in this implied-market approach.

Indeed, a CoCo bond behaves like a down-and-in put option for its holder and following the formulation of the Equity Derivative perspective, which assumes a constant volatility, it is reasonable to believe that the latter is unable to capture the real behaviour of the stock price. Down-and-in put options are known to be very sensitive to the volatility-smile (time-varying volatility) and the so-called leverage effect, for which a reduction of the stock price causes an increasing in the implied volatility. In addition, the sudden drops in the stock price, that are excluded from the mathematical formulation of Black and Scholes (1973), must be taken into account, due to the implicit link of the CoCo bond structure with the stock itself (seen as its underlying asset). For these reasons, I have made the choice to use the Bates model. The test of how a change in the underlying path of the latter one can affect the pricing model of the CoCos is achieved by a comparison of the Equity Derivative model under the original Black-Scholes assumption and its new formulation with the Bates model. In order to be applied, the model requires a market trigger, whereas the CoCo bond is issued with an accounting one. The lack of a relation to convert the accounting nature of the trigger to a market indicator makes it impossible to apply directly the pricing formula, at least without assuming it exogenously. Therefore, the pricing model is inverted and the implied market trigger is obtained by matching the market and the model prices. Rationally, if the accounting trigger level is constant for CoCos issued by the same institution, also the market trigger level should be fixed among different CoCos. Conversely if they are different, one can outline over- or undervaluations of the CoCos, according to the interpretation of Spiegeleer et al. (2017). In addition, a higher market trigger should be

1. Introduction

related to a higher trigger probability, which is also considered in the analysis, in order to infer if the extended model provides a riskier valuation of the CoCos.

Finally, due to the simple formulation of this market-implied model, a number of factors are analyzed in order to highlight which are the most important to affect the applicability of the model also to complex CoCo structures. For this purpose, it is also made a comparison with the Heston model (Heston, 1993), that does not include the jump component and the sensitivity analysis on the Bates model is performed to infer the impact of the calibrated parameters. The analysis is based on the procedure of Spiegeleer et al. (2017), which is applied to the Equity Derivative model extended with the Heston model for one TIER2 CoCo. In order to apply it to Additional TIER 1 CoCos, I make some assumptions that simplify the complexity of the CoCo bonds. Following the example made by Spiegeleer et al. (2014), I consider the first call dates of those CoCos their maturities, since they are issued as perpetuity. All the details are provided in section (5.1), together with the data used for the calibration of the Bates model.¹

Because of the simplified context, it is always possible to think about possible modification of this pricing model, including other sources of risk in the analysis, i.e. the extension risk usually linked to perpetual CoCos (the possibility of the bank to call back the CoCo), the cancellation of coupons, as well as the existence of the PONV regulatory trigger, extending the Equity Derivative framework with the use of double-barrier options. However, these implementations would make the application of the model less intuitive and closer to the cumbersome formulation of the structural models, giving up the simplicity of the implied-market approach. Concerning the nature of the trigger, that is not inferred directly, a modifications of the Equity Derivative model might be achieved with the use of the implied volatility of the CET1 Ratio. Thus, it can study the behaviour of the accounting trigger, as Spiegeleer et al. (2015) outline for the fully written-down CoCos.

The rest of the thesis is structured as follows: chapter 2 provides some preliminary concepts about the structure of CoCos, explaining their features and illustrating the financial and regulatory contexts. The following chapter goes through early literature and provides all the details about the Equity Derivative model, analyzing the extension of the implied-market pricing approach with the Bates model. Next, chapter 4 focus on the model implementation, going through the calibration and Monte Carlo simulations. Chapter 5 provides the details about the dataset and the results for Barclays CoCos. Lastly, the viability of the model is exploited by looking at the main factors that affect the model results.

¹Additionally, some parts of my MATLAB code are inspired by the formulations of Moodley (2005), Jung (2012) and K  ll (2014).

2 Understanding CoCo Bonds

"Contingent Convertibles, Contingent Capital, CoCos, Buffer Convertible Capital Securities, Enhanced Capital Notes, etc. are all different names for the same kind of capital instrument issued by a financial institution. Having different names for one and the same instrument clearly adds to the confusion surrounding this new asset class. [...] The fact that these contingent convertibles are often confused with the concept of bail-in capital is not helpful either" (Spiegeleer and Schoutens, 2012b, p.62).

Contingent convertible bonds are hybrid capital securities with higher coupon payments than ordinary bonds. They are issued by banks in order to ensure the loss absorption in case its capital falls below a certain level, through a conversion into share or a write-down of the face value. After the financial crisis of 2007-2008, their issuing is promoted by the new regulatory capital requirements of Basel III. Therefore, financial institutions use CoCos to reduce their default probability, having available an additional buffer by raising new capital without taking an excessive risk (EPRS, 2016). According to the extensive literature, the CoCo structure can easily meet the capital requirements, thanks to the lack of standard features that can be modified according to specific necessities. The first bank that issued CoCos was Lloyds Banking Group, as exchange offer in 2009. An year after, Rabobank launched € 1.2bn of contingent debt. Then in 2011, Credit Suisse followed with Buffer Capital Notes. Today, the market of the CoCo has increased hugely and during 2016, the majority of the CoCos have been issued to raise AT1 capital and pay an average coupon of 7% (Bloomberg, 2017).

2.1 Key Features

According to Spiegeleer et al. (2014), the structure of contingent convertible capital reflects the aim of the regulators and the financial authority. As Figure 2.1 summarizes, the main components of CoCos are the trigger event, the loss-absorbing mechanism, that takes place through a write down or a conversion into shares; and the host instrument.

2. Understanding CoCo Bonds

2.1.1 Loss-Absorption Mechanism

The conversion occurs at the trigger moment, t^* . In this case, the CoCo-bond holder faces either a conversion of his bond into shares or a write-down, which means that the face value is reduced partially or completely.

Figure 2.1: Contingent Convertible Bond Features

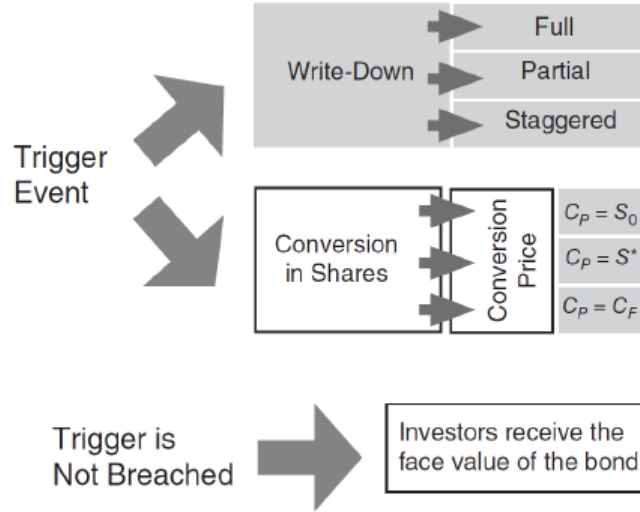

Source: Spiegeleer et al. (2014)

Conversion in shares

The conversion amount C_r is the number of shares that the CoCo holder receives at t^* . It is linked to the conversion price C_p and the face value of the CoCo bond N as follow:

$$C_r = \frac{N}{C_p}, \quad (2.1)$$

In this case, new shares are created. Hence, C_p , which is set in the prospectus of the financial institution, is crucial. The old shareholders would prefer to set the conversion price to a higher level, in order to avoid a wide equity dilution, meanwhile CoCo investors would be better off, as the conversion price decreases. According to Spiegeleer and Schoutens (2012a), the possible levels for C_p are:

- *Floating.* $C_p = S^*$

Let S^* be the share price observed on the market at t^* . By definition of the conversion on the trigger moment, the value of the shares on the market would be

2. Understanding CoCo Bonds

quite low, due to the moment of depression of the issuer. Thus, there would be a huge dilution for the old shareholders and it can be related to manipulation of the market by the bondholders (averse incentive to short-sell the stocks in order to gain even more shares for a lower price).

- *Fixed.* $C_p = S_0$

S_0 corresponds to the value of the shares at the moment of the issuance of the CoCos, therefore the level of the conversion price is high and the dilution is of course limited, being preferred by the shareholders.

- *Floored.* $C_p = \max\{S^*; S_F\}$

This is a compromise between the previous cases, where S_F is a floor set in order not to allow huge drops in the share price.

Despite the flexible nature of the CoCos managed by the issuers, who can choose freely one of these cases, the CoCo can not be seen as convertible bonds. The conversion mechanism is not enough to compare those two financial instruments. Contingent convertible bonds have a different payoff and it is limited to the face value N and the coupons. Figure 2.2 compares the trend of the payoff of those two categories and a straight bond with respect to the share price (underlying). An ordinary bond has a constant payoff in a risk-free framework and it is not linked to the equity-price path. If the bond is a convertible one, it means that its payoff is related to the stock price by the conversion ratio: consequently, the investor might become a shareholder still covering the downside risk holding such a financial instrument. Finally, CoCo bonds do not ensure any protection against the latter risk, being related to a limited upside gain (Spiegeleer and Schoutens, 2012a).

Given one of the previous case for C_p and recalling equation 2.1, the loss for the investor at the moment of conversion is given by

$$L_{CoCo} = N - C_r \cdot S^* = N \left(1 - \frac{S^*}{C_p} \right) = N(1 - \pi_{CoCo}). \quad (2.2)$$

π_{CoCo} is the so-called recovery rate of the CoCos. It is negatively related to increases of the conversion price. Higher C_p values leads to lower π_{CoCo} , meaning that there is a smaller dilution of the equity.

Write-Down

Coming to the case of the potential write-down, this feature is linked to the requirement of the CoCos to be loss absorbing. Indeed, the investor can face different kind of write-downs:

2. Understanding CoCo Bonds

Figure 2.2: Comparison of the Price of a Conventional Convertible Bond and a Contingent Convertible Bond

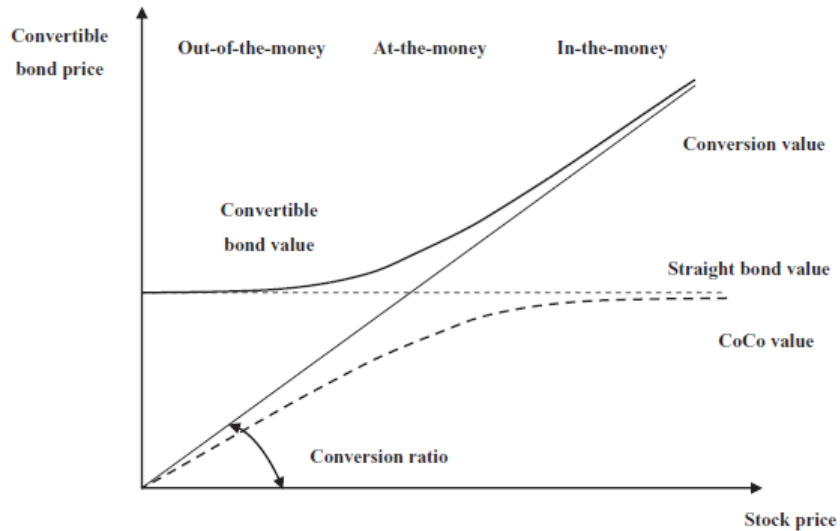

Source: Batten et al. (2014)

- *Full write-down*
The face value of the CoCo bond is entirely lost by the issuer at the trigger date.
- *Partial write-down*
The investor receives part of the face value, losing only the remainder part of his investment.
- *Staggered write-down*
The investor loses a part of the face value in order to achieve the recapitalization on the issuer in a flexible measure. His contribution is needed until the issuer reaches the capital-requirement level again.

The write-down mechanism can be preferred to the equity conversion. The former is considered more transparent, since the holders know the loss they might face since the beginning. Meanwhile, the latter is linked to potential dilution that additionally might change the control in a bank (Spiegeleer et al., 2014).

2.1.2 Activation Trigger

The trigger event causes the write-down on the face value of the CoCo bond or the conversion into shares. Therefore, the issuer can be recapitalized, strengthening its capital

2. Understanding CoCo Bonds

structure. So far, most of the CoCos have been related to accounting triggers. However, they have also an extra regulatory trigger, related to the discretion of the regulatory authority (usually the national regulator), who forces the loss-absorption mechanism. The nature of the trigger events is the basis for their classification (Spiegeleer and Schoutens, 2012a and Spiegeleer et al., 2014).

Accounting Trigger

CoCo bonds with this kind of trigger are associated to an accounting measure, which is typically the CET1 ratio. Thus, a barrier level is chosen in the contract of the financial instrument, such that the conversion into shares or the write-down would be activated whenever the accounting ratio falls below that level, as specified in section 2.2. Even if this measure is well-defined by the Basel Committee, there is the possibility of distortions by the internal management of the issuer, together with the fact that this measure is observed only quarterly or semi-annually, causing a nontransparent view of the health of the issuer.

Market Trigger

A market trigger is an event related to market data. Examples of these indicators are the Credit Default Swap (CDS) spread and the equity price (underlying asset of the CoCos). It constitutes the easiest trigger to price a CoCo bond. Thus, under the assumption of liquid and efficient markets, it is straightforward to analyze the health of the issuer and obtain an accurate financial measure at any point in time. However, its limitation is the possibility of market manipulations, that can alter the stock prices, especially when the CoCos are close to the trigger event. Indeed, the CoCo holders can arrange a short selling of the stocks, hedging their positions by causing a drop in the stock price, to finally gain more stocks.

Regulatory Trigger

The discretion of the national regulator can activate the trigger. This clause is also called Point Of Non-Viability (PONV). Based on the latest evidence, the regulatory trigger can be set to a higher level than the ones of the previous categories. Indeed, it is linked to the ability of the issuer of keeping a good quality of the Additional TIER 1 and TIER 2 capital. Obviously, the existence of such a trigger erodes the value of the CoCo bond, being difficult to quantify the time when the loss-absorption mechanism will happen. However, it overcomes problems related to the accounting trigger as well as the manipulation of market indicators.

2. Understanding CoCo Bonds

Multivariate Trigger

A financial institution can issue CoCos with different triggers, comprising several triggers of either the same nature or different ones. For example, a CoCo bond can be structured with a trigger that reflects the macro-economic condition together with an accounting or a market trigger. Multiple triggers are proposed by Flannery (2009), and by the Squam Lake working Group on Financial Regulation (2009) with specific attention to a macro variable (state of the economy) and a micro variable (state of the issuer). The former can be achieved by the use of a financial index as a proxy of the trend of the financial sector as a whole, meanwhile the latter reflects more the specific internal situation of the financial institution. Although the advantage of having multiple triggers can prevent from a systemic crisis, some could argue that in case that a macro-type trigger is activated, the banks in a good situation would face an over-capitalization (Spiegeleer et al., 2014).

Solvency Trigger

This category includes contingent convertible bonds that are related to the dynamics of a solvency ratio of the financial institution.

2.1.3 Host Instrument

The structure of the CoCo is built either on the coupon-bearing debt or a convertible bond. Considering the fact that they can be classified as AT1 or T2 capital and that their nature lays in between equity and debt, contingent convertible bonds ensure lower costs of capital than equity (as coupon payments can be tax deductible) and they offer higher coupon rate than bonds. Even though some features of the CoCos are constant for both the capital categories, such as the existence of a PONV (decided by the regulator) or the issuer trade-off between the eligibility of the regulatory capital and the cost of issuance (Avdjiev et al., 2013), CoCos can be modified in their structure. On the one hand, the higher the pressure from the regulators, the higher the trigger level, meaning that in order to boost its TIER 1 capital, the bank issues CoCos as Additional TIER 1 instead of TIER 2 capital (CoCos with low-trigger level and relative lower loss-absorbing capacity). On the other one, liabilities of AT1 type have to meet high-quality parameters, namely a loss absorption must be ensured in a going-concern context, they can suffer of a coupon cancellation and they have theoretically an unknown maturity; they are classified as perpetual CoCo bonds with several call dates of which the first one is settled at least five years after their issuance (Spiegeleer et al., 2015).

2.2 Regulatory framework

Actually, the development of CoCos happened only after the financial turmoil of 2007 and 2008, when the world faced the fragility of the entire financial system. Since then, new regulatory changes with the Basel Committee for Banking Supervision (BIS) has been focusing on how to reduce systemic risk in large financial institutions and how to ensure a complete loss absorption (BIS, 2011a). The Basel Committee has developed a set of reforms for the banking sector including the supervision, the regulation and the management of the risk, aiming the quality, the consistency and the transparency (BIS, 2009).

First of all, the regulatory capital of financial institutions has been divided in different categories. The difference accounts for the reliability of the financial instruments. The division is made between:

- TIER 1 Capital (T1 - Core Capital)
 - Common Equity TIER 1 (CET1)
It is almost only made up by the equity.
 - Additional TIER 1 (AT1)
It includes all the other instruments that are classified as TIER 1, i.e. perpetual hybrid securities (some kinds of convertible bonds, CoCos, etc.) that have similar features to the equity.
- TIER 2 (T2 - Supplementary Capital)
Financial instruments that are not easily liquidated, such as unsecured or revaluation reserves, other hybrid instruments and subordinated debt.

TIER 1 capital must ensure the *going-concern* of the bank, meaning that those financial instruments must have an easily liquidation not only during times of distress. On the contrary, TIER 2 capital is used only in case of insolvency of the bank (*gone-concern*). Moreover according to the regulatory authority (BIS), by 2019 the Core Tier 1 Capital (CET 1) over the Risk Weighted Assets must reach a minimum level of 4.5%. Indeed, it represents a measure of the solvency and the strength of the bank. The fact that the CET 1 is rescaled for the RWA creates a standard measurement of the risk borne by the bank, once the RWA is defined as the total assets, weighted for the different levels of risk.

CoCos take part of the regulatory capital of the banks, being classified AT1 and T2 capital as Figure 2.3 shows, depending on the features they have at the issuing. For instance, both the categories share the PONV requirements, i.e. the existence of the power of the

2. Understanding CoCo Bonds

regulatory authority to activate the loss-absorption mechanism, meanwhile only the AT1 instruments must have an infinite maturity (perpetuity). Then, the trigger level of the AT1 category, in case it is an accounting trigger on the CET 1 Ratio, must be at least above the CET 1 minimum level (at least 5.125% of the RWA, as required by Basel III).

Figure 2.3: Regulatory Capital Requirements under Basel III

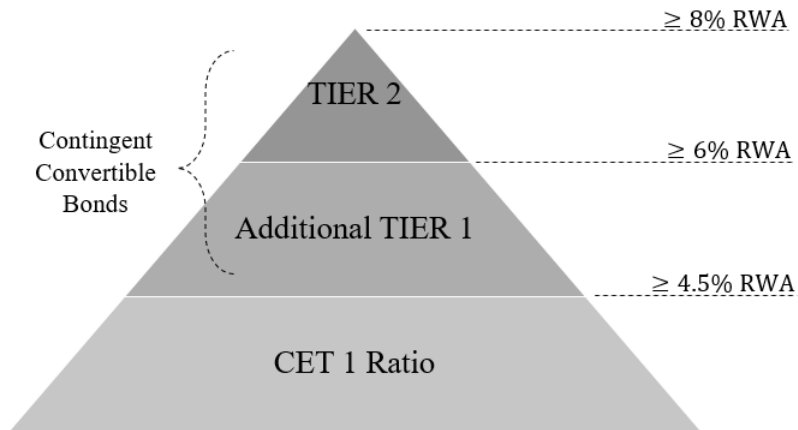

3 The Pricing

3.1 Literature Review

Hilsher and Raviv (2014); Flannery (2009) and Avdjiev et al. (2015) outline that the issuance of contingent convertible bonds brings a positive effect in the market (in terms of equity prices and CDS spreads), if there is the perception of a lower default probability of the banks. Flannery (2002) is the first to present a new type of bonds, called "Reverse Convertible Debentures", which belong to subordinated debt, with the possibility to be converted into common equity, whenever the market capital ratio of the bank falls below a predetermined level. Flannery shapes the automatic conversion to deleverage the bank capital during *hard times*.

From then on, a comprehensive analysis of the pricing approaches has been needed, in order to evaluate how the price of these hybrid instruments changes according with the variation of different risk indicators of the issuer, checking the reduction of the systemic risk. Thus, the literature, regulators and financial institutions themselves continue to extend the research, focusing on the qualitative aspect of how CoCos can fulfill the resilience and the soundness of financial institutions in distress. Nevertheless, the implementation assumes several forms. An overview of the existing models for CoCos is given by Wilkens and Bethke (2014). They divide the pricing approaches into three categories:

1. Structural models²
2. Equity derivatives models³
3. Credit derivative models⁴

Structural models

Starting with the dynamic of the balance sheet of a bank, the structural models analyze the impact of the issuance of contingent convertibles on the capital structure. This category

²See, e.g. Albul, Jaffee and Tchisty (2013); Brigo, Garcia and Pedo (2013); Cheridito and Xu (2013); Glasserman and Nouri (2012).

³See, e.g. Corcuera, Spiegeleer, Ferreira-Castilla, Kyprianou, Madan and Schoutens (2013); De Spiegeleer and Schoutens (2012).

⁴See, e.g. Spiegeleer and Schoutens (2012).

3. The Pricing

includes the works of Albul et al. (2010), Brigo et al. (2015), Glasserman and Nouri (2012) and Pennacchi (2010). After the introduction of the CoCos by Flannery (2002 and 2009), the pricing is outlined according to the choice of the trigger. Batten et al. (2014) argue that pricing models are developed starting with the contingent claim framework of Ingersoll (1977); the Black and Scholes (1973) and Merton (1976) model. Even though the structural valuation is more complicated than pricing ordinary financial instruments, these models can achieve the pricing of CoCos studying directly the behaviour of accounting triggers.

These models assume that the asset value follows a stochastic process and define debt and equity of the bank as functions of that process. For instance, Pennacchi (2010) develops a structural risk model, based on the debt-to-equity ratio at the time of the CoCos issuance. This kind of models can give an insight of the mechanism behind the relation between the capital structure and the triggering probability. However, due to the complexity of determining the corresponding drivers, it might be hard to find a closed formula. Indeed, only under specific assumptions Albul et al. (2010) reach closed-form expressions for the price. Glasserman and Nouri (2012) develop a structural model, assuming that the assets follow a Geometric Brownian Motion (GBM). They study the behaviour of CoCos with a capital ratio trigger and an on-going partial write-down, arriving to a close-form solution for their market value.

Equity Derivatives Models

The Equity Derivative models are classified as implied-market approach and are easier than the structural models. It is constructed on the assumption that the nature of the trigger of the CoCo is associated to a market trigger. Then, the CoCo bond is analyzed from the equity-investor view point. Thanks to their hybrid nature, this approach replicates and values the exposure of the CoCo investor, who holds implicit shares. According to the model developed by Spiegeleer and Schoutens (2012a), the payoff of a CoCo bond can be seen as a portfolio of several derivatives. Therefore, the payoff is decomposed into three parts that are valued separately. The first one is a straight bond, the second one is a knock-in forward and the third one is the sum of binary down-and-in options. Further extensions are done by Spiegeleer et al. (2017), Corcuera et al. (2013) and Teneberg (2012), in order to include higher fat-tail risk with smile conforming models. In fact, the main disadvantage of the Equity Derivative model is that the use of the Black-Scholes formula is not sufficient to account for the fat-tail dynamics that CoCos have. Following this kind of approach, Gupta et al. (2013) extend the pricing model to several contractual features of CoCo bonds, including also a mean-reverting capital ratio.

3. The Pricing

Credit Derivatives Model

Also the Credit Derivative model is considered a market-implied approach. In this case, one can focus on the fact that the conversion of a CoCo bond is deeply linked to the firm default, such that the respectively survival probability can be used to obtain an intensity-based credit model. Again, Spiegeleer and Schoutens (2012a) develop the CoCo spread as a function of the triggering probability (exogenous) and the related expected loss under conversion. This model follows the same approach used to calculate the spread of a Credit Default Swap, using the same kind of approximations and the so called CDS *rule-of-thumb*.⁵ The result is a quick method to implement CoCos valuation.

Extensions and Enhancements

In the light of the new market framework of the contingent capital, many market practitioners argue how it is easier to calibrate the model parameters with the market prices, using the reduced form approach. The higher flexibility is introduced by Spiegeleer and Schoutens (2012a) through the approximation of the accounting trigger with a market trigger, i.e. the first time the stock price hits a barrier level. Then, Wilkens and Bethke (2014) exploit other aspects of the equity derivative model and the credit derivative one. The former does not fit very well the data, even though it performs best in both the hedging and the straightforward parametrization. Meanwhile, the latter is very useful when the hedging ratio is taken into account to analyze the risk management of CoCo bonds. However, both of them can be affected by market manipulation, due to the fact that are based on market value.

On the other side, structural models completely fulfill the pricing of CoCos, due to their rigorous formulation of the capital ratio. This is the key factor to take into account all the contractual features of contingent convertible bonds with an accounting trigger. Indeed, the capital ratio is directly obtained from the balance sheet. However, such models are not easy to handle in terms of calibration using market data and of the joint dynamics of the capital ratio and the stock price (as a contingent claim on the bank asset value). Another complexity is introduced when jumps in stock prices and potential write-downs of the CoCo-bond value are taken into account, requiring even further restrictions.

Finally, the category of the hybrid models is considered in between the structural approach and the reduced-form one. They belong to the reduced-form models and use the

⁵Let λ be the default intensity (small value) and π the CDS recovery-rate, then $\text{Spread}_{\text{CDS}} = \frac{\lambda}{1-\pi}$.

3. The Pricing

assumption that the conversion happens either if the capital ratio (accounting trigger) hits the barrier level or if the stock price has a jump (regulatory trigger). This kind of implementation is carried out by Carr and Linetsky (2006), Carr and Wu (2009), Cheridito and Xu (2012), Chung and Kwok (2014), who model the interaction between equity risk and credit risk. Those hybrid models capture the flexibility of the market-implied models and the accuracy of the structural models.

3.2 The Equity Derivative Approach

With the choice to associate the trigger level of the CoCo (accounting or regulatory nature) to the path of the stock price that might hit a barrier level, it turns out that the latter value, S^* , corresponds to the market value of the stock when the CoCo is triggered⁶ (t^*). The correspondence between the two events is shown in Figure 3.1.

Figure 3.1: Accounting Trigger ($CET1_t$) vs. Market Trigger (S_t)

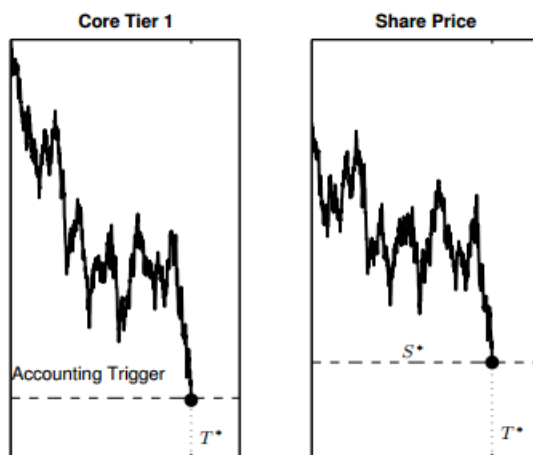

Source: Spiegeleer and Schoutens (2012a)

The derivation is easily explained starting by outlining the payoff of a CoCo bond at maturity, with a face value N . For clarity, it is assumed a zero coupon bond and a trigger event that brings an equity conversion (however, the same can be done considering an α -write-down mechanism, with $0 \leq \alpha \leq 1$),

$$\text{Payoff}_{CoCo,T} = \begin{cases} C_r S^*, & \text{if conversion} \\ N, & \text{if no conversion.} \end{cases}$$

⁶The full notation of S^* is S_{t^*} .

3. The Pricing

Let S_t be the stock price at time t , then the trigger event t^* is defined as the first time the stock price falls to the barrier level.

$$t^* = \min_t \{S_t \leq S^*\} \quad (3.1)$$

Using a trigger indicator, $1_{\{t^* \leq T\}}$, which equals 1 in case of triggering and zero otherwise, the payoff can be rewritten as

$$\text{Payoff}_{CoCo,T} = N \cdot 1_{\{t^* > T\}} + C_r S^* 1_{\{t^* \leq T\}}. \quad (3.2)$$

First of all, the intuition behind this kind of notation is that the conversion time, t^* , happens before the default of the financial institution. Then, in the valuation of a CoCo bond, the host instrument (zero-coupon bond, in this case) and the implicit long position in C_r stocks are taken into account separately, adding the coupon structure in case the host instrument is a coupon bond. This thesis follows the formulation of Spiegeleer et al. (2017), under which the price of a contingent convertible bond is seen as a combination of a Coupon Bond (A), with periodical coupon payments and face value N paid back at maturity T ; and several derivatives, that incorporate the loss-absorbing feature. Referring to the equation 3.3, the first loss-absorbing component (B) is what the investor receives at t^* as amount of shares, modeled by C_r down-and-in asset-(at hit)-or-nothing option and a short binary down-and-in (BDI) option with maturity T , due to the fact that the investor loses the face value, N . The last component (C) is a portfolio of short binary down-and-in (BDI) options that cancel all the coupon payments after the trigger moment t^* .

$$\begin{aligned} P_{CoCo} &= A + B + C \\ &= \text{Coupon Bond} \\ &\quad + (C_r \cdot \text{down-and-in-asset-(at hit)-or-nothing option on the stock} \\ &\quad \quad - N \cdot \text{binary down-and-in option}) \\ &\quad - \sum_i c_i \cdot \text{binary down-and-in option} \end{aligned} \quad (3.3)$$

The structure of the CoCo components of equation 3.3, follows the derivation of Rubinstein and Reiner (1991) for the barrier options and the price can be calculated for all kind of CoCo bonds. For example, a fully write-down CoCo is analyzed assuming that C_r is zero, which means, by equation 2.1, that C_P can be set equal to $+\infty$ or to an extreme high level (Spiegeleer et al., 2017).

3. The Pricing

The Coupon Bond

The present value of the payoff of a coupon bond corresponds to

$$A = N \cdot \exp(-r(T-t)) + \sum_{i=1}^k c_i \cdot \exp(-r(t_i-t)),$$

where r is considered the constant risk-free rate and c_i the coupon payment at time t_i .

The Loss-Absorbing Components

The second part of the CoCo value is made by several derivatives.⁷ First of all, the C_r down-and-in-asset-(at hit)-or-nothing on the stock is a put option that corresponds *nothing* in case the stock price (underlying asset) is higher than the implied trigger level S^* (strike price) and C_r *stocks* otherwise.

The short position on the BDI option has a payoff that follows a cash-or-nothing call option, due to the fact that it pays *nothing* if the stock price hits the barrier level (strike price) or *cash* if it stays above S^* (the cash amount in this case is equal to the face value N).

The portfolio of BDI options follows again the payoff of a cash-or-nothing call option. This time the cash amount is equal to the constant coupon payment c_i .

The computation of their present value, given that $\mathbb{P}[t^* \leq T] = \mathbb{E}[1_{\{t^* \leq T\}}]$, is equal to

$$\begin{aligned} B &= C_r \mathbb{E}[S^* e^{-r(t^*-t)} 1_{\{t^* \leq T\}}] - N e^{-r(T-t)} \mathbb{P}[t^* \leq T]. \\ C &= - \sum_i c_i \cdot e^{-r(t_i-t)} \mathbb{P}[t^* \leq t_i]. \end{aligned} \tag{3.4}$$

3.2.1 The Black-Scholes Setting

In the Black-Scholes model, the stock price S_t is defined as GBM,

$$dS_t = (r - q)S_t dt + \sigma S_t dW_t, \tag{3.5}$$

in which the risk-free rate and the dividend yield q are constant as well as the stock volatility σ and W_t is a standard Brownian motion, under the risk-neutral measure \mathbb{P} .

Therefore, the stock price is log-normally distributed and through the application of the Itô's Lemma, it takes future values according to the following expression.

$$S_t = S_0 \cdot \exp\left(\left(r - q - \frac{1}{2}\sigma^2\right)t + \sigma W_t\right).$$

⁷For the payoff derivation see Hull (2014).

3. The Pricing

Closed-Form Solution

Only this kind of setting allows for a closed-form solution for both plain-vanilla and barrier options. Therefore, the loss-absorbing components are calculated under the risk-neutral probability \mathbb{P} and they correspond to

$$\begin{aligned}
 B &= C_r \cdot S^* \left[\left(\frac{S^*}{S_t} \right)^{a+b} \Phi(z) + \left(\frac{S^*}{S_t} \right)^{a+b} \Phi(z - 2b\sigma\sqrt{T-t}) \right] \\
 &\quad - N \cdot \exp(-r(T-t)) \cdot [\Phi(-x_1 + \sigma\sqrt{T-t}) + \left(\frac{S^*}{S_t} \right)^{2\lambda-2} \Phi(-y_1 - \sigma\sqrt{T-t})] \\
 C &= - \sum_i c_i \cdot \exp(-r(t_i-t)) \cdot [\Phi(-x_{1i} + \sigma\sqrt{t_i-t}) + \left(\frac{S^*}{S_t} \right)^{2\lambda-2} \Phi(-y_{1i} - \sigma\sqrt{t_i-t})],
 \end{aligned} \tag{3.6}$$

with

$$\begin{aligned}
 z &= \frac{\log\left(\frac{S^*}{S_t}\right)}{\sigma\sqrt{T-t}} + b\sigma\sqrt{T-t} \\
 a &= \frac{r - q - \frac{1}{2}\sigma^2}{\sigma^2} \\
 b &= \frac{\sqrt{(r - q - \frac{1}{2}\sigma^2)^2 + 2r\sigma^2}}{\sigma^2} \\
 x_1 &= \frac{\log\left(\frac{S_t}{S^*}\right)}{\sigma\sqrt{T-t}} + \lambda\sqrt{T-t} \\
 y_1 &= \frac{\log\left(\frac{S_t}{S^*}\right)}{\sigma\sqrt{T-t}} + \lambda\sqrt{T-t} \\
 x_{1i} &= \frac{\log\left(\frac{S_t}{S^*}\right)}{\sigma\sqrt{t_i-t}} + \lambda\sqrt{t_i-t} \\
 y_{1i} &= \frac{\log\left(\frac{S_t}{S^*}\right)}{\sigma\sqrt{t_i-t}} + \lambda\sqrt{t_i-t} \\
 \lambda &= \frac{r - q + \frac{1}{2}\sigma^2}{\sigma^2}
 \end{aligned}$$

in which Φ is the c.d.f. of a standard normal distribution, r is the risk-free rate, q the dividend yield and σ the volatility of the stock price.

Comparative Statics

In order to investigate how the model behaves with respect to changes in its parameters, a base case is taken into account, varying only one parameter at time. For this purpose, let a 5 year-maturity CoCo bond have a face value of 100 and an annual coupon rate of 5%

3. The Pricing

with quarterly coupon payments. The market trigger level is set at a level of 50 and the conversion price of 100.

The data are summarized in Table 3.1, together with the interest rate, the dividend yield, the stock price at $t = 0$ and its volatility.

Table 3.1: Example: Base Case Data of a CoCo Bond with Quarterly Coupons

S_0	S^*	T	N	C_P	σ	r	q	Cpn
100	50	5	100	100	0.2	0.01	0.02	0.05

The correspondent price of the CoCo bond obtained with the model is 176.59. The following analysis exploits the sensitivity of a fully converted CoCo bond price and its components (A, B and C) to the variations of some parameters. Figure 3.2 shows respectively the prices as a function of the conversion price C_P , the implied trigger level of the stock price S^* , the stock price S_t at time $t = 0$, the maturity of the CoCo bond T and the volatility σ . Finally the case of a write-down CoCo is shown, in which there is no conversion into shares but only the write-down of a percentage of the face value ($\alpha \cdot N$).

The price of the CoCo bond is monotonically decreasing with respect to the increase of the conversion price up to the value of the stock price, S_0 . Indeed, C_P determines the conversion ratio, namely the number of shares that the investor receives as the CoCo bond is triggered. Next, S^* is inversely related to the price of the CoCo bond, due to the fact that if S^* increases, the difference between the stock price S_0 and the stock-barrier level shrinks, thus it is more likely that the contingent convertible bond is converted. This effect can be seen also in the increasing price of component B, which behaves almost like a knock-in forward,⁸ such that the investor has a higher probability to receive it. An increase in the stock price produces, instead, a convergence to the value of the coupon bond. Indeed a high level of S_0 , for a fixed barrier level S^* , means that the CoCo bond has a trigger probability that approaches zero, therefore it will behave as a straight coupon bond until maturity. Analyzing the maturity T , the price of the CoCo bond increases as the number of coupon payments grows. However, the price does not grow as much as the ordinary bonds, due to the existence of the loss-absorbing feature. Furthermore, in terms of Black-Scholes volatility, the CoCo bond has a decreasing price. Indeed, the higher the volatility, the higher the probability of conversion, due to the fluctuation of the stock price. Hence, the loss-

⁸The knock-in forward is the second component of the Equity Derivative model in its original formulation (Spiegel and Schoutens, 2012). Even though Spiegel et al. (2014) formulate the model slightly differently, the behaviour of the B element remains the same.

3. The Pricing

Figure 3.2: Example: Comparative Statics of the Equity Derivative model using the Black-Scholes Volatility

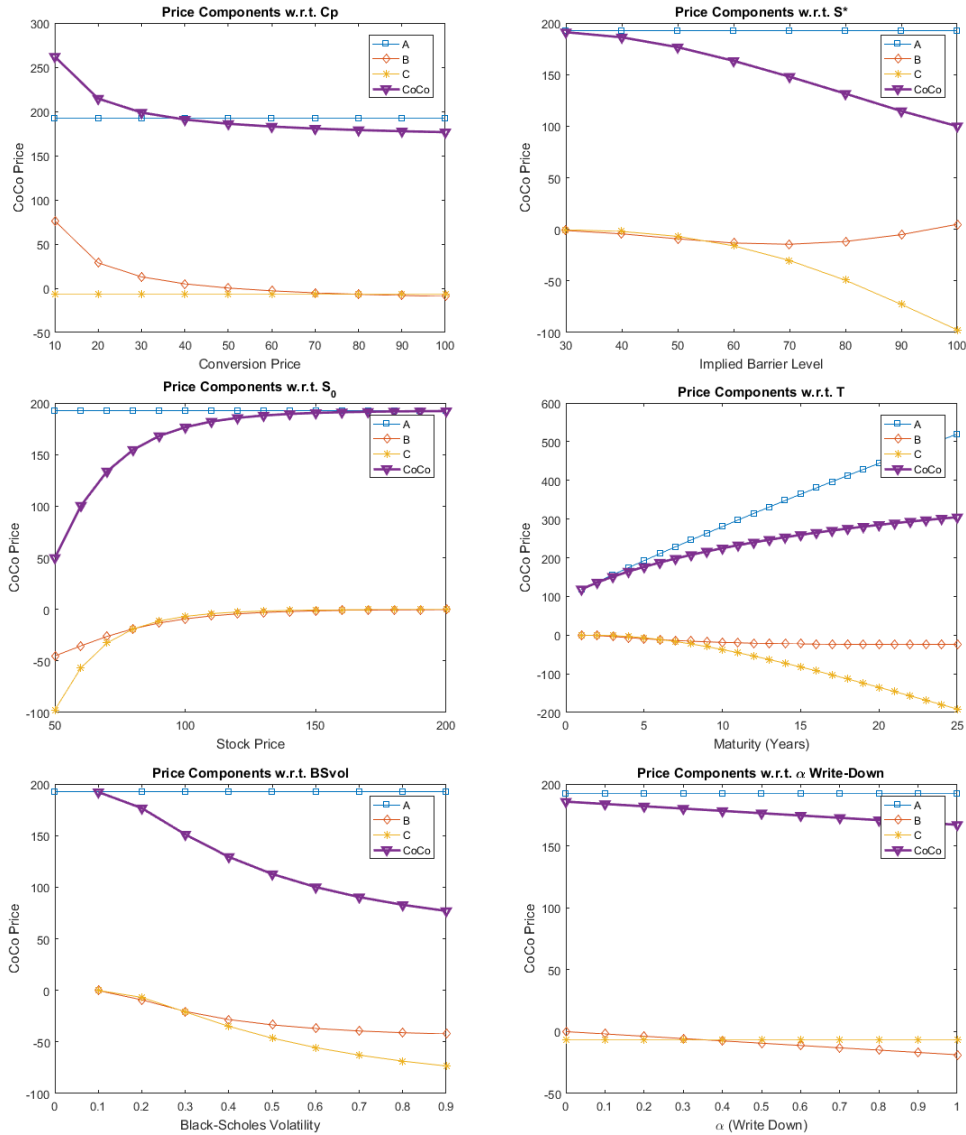

absorbing components have a higher weight with respect to the coupon-bond component, which is flat. Finally, the case of no conversion shares and a the write-down of the face value is expressed through the percentage α . It highlights that the price of the CoCo bond linearly decreases as α approaches 1. This is exactly the case in which the face value as a whole is written down and the holder faces the maximum loss.

3. The Pricing

3.2.2 Beyond Black and Scholes

The stock dynamic is one of the key element in the CoCo valuation. Its price impacts on the existence of the trigger probability and the correspondent loss faced by the holder. Thus, it is important to assume a stock behaviour as close as possible to the one observed on the market. Then, the sensitivity of the barrier options to the stochastic volatility of the stock price affects the formulation of the Equity Derivative model, under which the CoCo price is seen as a BDI put option for the holder.

This section explains the reasons why a constant volatility, such as the case of the Black-Scholes model, does not suite the case of the CoCo valuation. Then, it provides a static analysis of the implied volatility, explaining the introduction of a new model and how its parameters contribute to the volatility skew.

Volatility Surface

Starting with the Black-Scholes environment we can use the option pricing formula and invert it, in order to look at the implied volatility (IV). Plotting those results with respect to the strike prices of the options, we obtain the so-called volatility smile, instead of a constant straight line (constant IV). The volatility smile has almost a "U"-shape and it tends to look like a smirk, due to its left asymmetry. Then, looking at the IVs in terms of the strike prices and the maturities of the options, the volatility surface can be obtained. The non-constant shape of both the curve and the surface is the result of the negative correlation between stock returns (underlying asset of the options) and its volatility, that is empirically shown by e.g. Black (1976).⁹ Beside the negative relation, Black shows that if the value of the stocks falls, the stock volatility increases a lot, since the equity-to-total-assets ratio of the firm shrinks (i.e. the risk of the firm increases). The phenomenon, called *leverage effect*, proves how the market reacts more to bad than good news, generating an asymmetric effect in the shape of the volatility skew. Therefore, it explains not only the convexity of the option price with respect to the volatility, but also that the empirical probability distribution of the stock returns is far from being normally distributed. The resulting distribution function is, indeed, leptokurtic, showing higher concentration in the tails and an high peak around the mean value.

For this purpose, the introduction of a stochastic volatility (SV) overcomes the problem of the tail-risk underestimation. The most famous model that adds the SV to the Black-Scholes formulation is the Heston model (Heston, 1993), in which the time-varying

⁹A wide literature is proposed by Hibbert et al. (2008).

3. The Pricing

volatility is related to the process of the stock price by a constant correlation between two Brownian motions $(W_t^{(1)})_{t>0}$ and $(W_t^{(2)})_{t>0}$, as follow.

Heston Model

$$\begin{aligned}dS_t &= (r - q)S_t dt + \sqrt{v_t}S_t dW_t^{(1)}, \quad S_0 > 0 \\dv_t &= \kappa(\eta - v_t)dt + \lambda\sqrt{v_t}dW_t^{(2)}, \quad v_0 = \sigma_0^2 > 0.\end{aligned}\tag{3.7}$$

The stock path has a stochastic variance with respect to the GBM-dynamics under Black and Scholes. More in details, its volatility is modeled as a mean-reverting Cox-Ingersoll-Ross (CIR) process, in which

$\kappa > 0$ is the speed of mean reversion

$\eta > 0$ is the long-run mean of the variance

$\lambda > 0$ is the volatility of the variance

$\rho dt = \text{Cov}[dW_t^{(1)}, dW_t^{(2)}] \in [-1, 1]$ is the correlation of the two Brownian motions.

This model has a suitable application, due to the existence of a quasi-closed formula for European options, that is easy to implement. However, the SV alone does not provide a perfect representation of the real stock-price behavior. Indeed considering short periods of time, the stock process in the Heston model behaves like a Brownian motion, without the possibility to change by large amounts. Hence, the prices obtained from the model do not fit very well the ones in the market, especially when we try to evaluate the prices of out-of-the-money options.

Stock Jumps

For the kind of data used in this thesis in section 5.1, which is based on OTM options to reflect the features of Barclays' CoCos, jumps in the stock price are added to the Heston model. The result is the Bates model (Bates, 1996) that considers a stochastic volatility and a jump-diffusion process (SVJ). It captures the sudden, (mainly) negative variations of the market returns, using a Poisson process for the jump component. This structure recalls the jump-diffusion process of Merton in the Black-Scholes environment (Merton, 1976).

Merton Model

$$dS_t = (r - q - \lambda_J \mu_J)S_t dt + \sigma S_t dW_t + S_t J dN_t\tag{3.8}$$

3. The Pricing

with

$$\sigma = \sigma_{BS}$$

N_t is the Poisson process independent of W_t , such that

$\lambda_J > 0$ is the constant intensity of the jumps and

μ_J, σ_J are respectively the drift and the volatility of the jumps

J is the log-normal jump size in percentage, such that

$$J = \mu_J \exp\left(-\frac{1}{2}\sigma_J^2 + \sigma_J \cdot z\right), \quad z \sim N(0, 1).$$

The formulation allows the mean of the jumps to have a probability density with fatter-tails. If μ_J takes negative values, the left tail is affected more and vice versa. The volatility of the jumps creates higher peaks in the shape of the density function. The last parameter is λ_J . If the jump intensity is low, then there is a concentration around the mean and the density function has a high peak.

The Bates Model

Putting together the previous two models, the SVJ model uses the Heston model formulation and adds a compound Poisson process with Gaussian jumps, as follow.

$$dS_t = (r - q - \lambda_J \mu_J) S_t dt + \sqrt{v_t} S_t dW_t^{(1)} + S_t J_t dN_t, \quad S_0 > 0 \quad (3.9)$$

with the v_t process of the Heston model - equation 3.7 - and the Merton's jump process with J_t still log-normally i.i.d. distributed such that

$$\log(1 + J_t) \sim N\left(\log(1 + \mu_J) - \frac{\sigma_J^2}{2}, \sigma_J^2\right).$$

Gatheral (2011) explains how this model performs even better than the model with jumps in both the processes of the stock and the volatility. Indeed, the SVJ model is seen as a compromise between the number of parameters to be fitted and the accuracy in the stock path formulation.

Parameter Analysis

Analyzing the parameters of the Bates model, we can evaluate how they interact with the Implied Volatility. Figure 3.3 shows two examples of the shape of the volatility smile with respect to ρ and λ . The representations are based on sample strike prices, [80;120] for European call options with one-year maturity. The variations are made changing one

3. The Pricing

parameter at time.¹⁰ The stock price is equal to 100 and it is reported in the Table below, together with the resulting parameters of the calibrated Bates model, which are explained in the following chapters. As preliminary case, it is only discussed the behaviour of the Implied Volatility with respect to some Bates parameters.

Table 3.2: Example - Data for the Implied Volatility of European Call Options

		S_0	K	T				
		100	[80;120]	1				
κ	η	λ	ρ	σ_0	λ_J	μ_J	σ_J	
4.6048	0.0031	0.1189	-0.4695	0.1819	1.1018	-0.1399	0.2772	

Figure 3.3 can be considered the contribution of the "Heston" parameters of equation 3.7 on the leptokurtic shape of the stock density function. In particular, the tails are function of the correlation between the stock and its volatility process, due to the fact that switching from a negative to a positive ρ , the left asymmetry decreases and the right tail becomes heavier. Next, the volatility of the volatility affects more the kurtosis. Indeed, increasing values of λ , the volatility smile shows higher levels of asymmetry (more concentration around the mean value and on the tails). Even though the reaction of the volatility skew to these kinds of changes appears to be very tiny, an increase of the negative correlation (ρ) as well as a decrease of λ have a greater impact for OTM call options (right side of the graphs, being $K > S_0$), for which the slope in their IVs changes more. Doing the same exercise

Figure 3.3: Effect of ρ and λ on the Volatility Smile of European Call Options with one-year maturity and an underlying stock value of 100

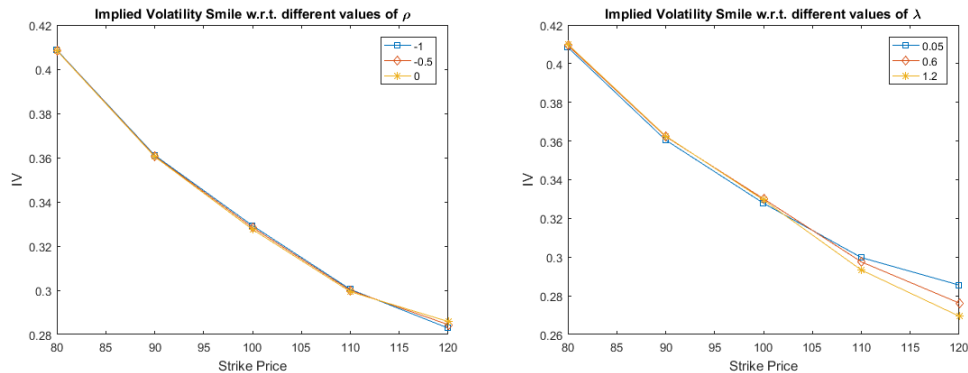

¹⁰The MATLAB code uses `blsimp`, in order to draw the Black-Scholes IVs from the option prices of the Bates model.

3. The Pricing

Figure 3.4: Effect of (negative) μ_J and σ_J on the Volatility Smile of European Call Options with one-year maturity and an underlying stock value of 100

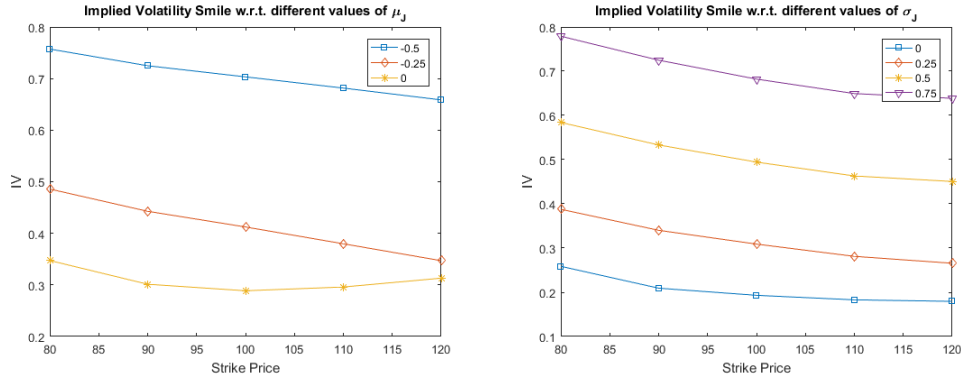

for the parameters used for the stock jumps, Figure 3.4 shows again a left-asymmetry of the volatility smile with respect to some variations of the mean and the volatility of the jumps. If the former increases the asymmetry grows. Indeed increasing σ_J increases not only the IV, but also the slope of the volatility skew. Then, the Figure shows the case of a negative μ_J , that affects the left-tail. Conversely, a positive value of the mean of the jumps creates a right skew. This effect is a consequence of the impact given by $\mu_J = 0$, which gives a "flatter" U-shape to the volatility smile, removing the left asymmetry. Finally, the case of λ_J affects the existence of the jumps. Indeed, if the parameter is set equal to zero, the Bates model regresses to the Heston model. Increasing the jump size, the convexity of the volatility smile is removed up to $\lambda_J = 1.2$, for which it increases the left asymmetry, becoming almost linear (Figure 3.5).

Figure 3.5: Effect of λ_J on the Volatility Smile of European Call Options with one-year maturity and an underlying stock value of 100

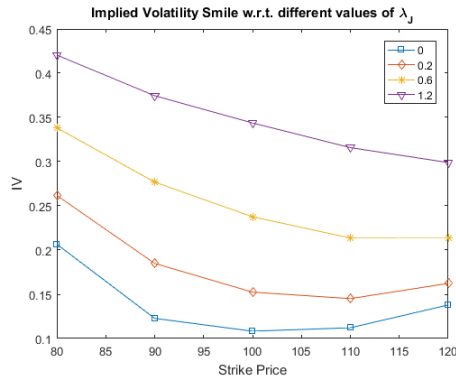

4 The Bates Model for CoCo Valuation

Once the model is chosen, it is used to obtain the price of the CoCos in the Equity Derivative framework. First, the Bates model must be calibrated, in order to have reasonable parameters to price those financial instruments. It is achieved by the use of data that are consistent with the specific structure of the CoCos (long term maturities and triggering even). In a second step, the payoff of the CoCos is evaluated with Monte Carlo simulations, due to the lack of a closed formula to evaluate the barrier options, implied by the formulation of the Equity Derivative model. Finally, the price of the CoCo corresponds to the present value of that payoff.

4.1 Calibration

The optimal values of the parameters are obtained using the characteristic function of the Bates model and computing the prices of the options in the dataset. Indeed, in order to be able to use a model, it should reproduce similar prices to the market prices for European options. Therefore, the parameters of the model are fitted by matching the market price P_i with the model price \hat{P}_i , for any option. The calibration is implemented using the minimization of the weighted Root Mean Square Error (w-RMSE), performed with the Nelder-Mead algorithm.¹¹

$$\text{w-RMSE} = \sqrt{\sum_i w_i (P_i - \hat{P}_i)^2}, \quad (4.1)$$

in which w_i is the corresponding weight to the i -th price, as it is explained in section 5.2.

Furthermore, the optimization problem is carried out checking the Feller condition:

$$\kappa \geq \frac{\lambda^2}{2\eta}. \quad (4.2)$$

It ensures that the square root of the variance, $\sqrt{v_t}$, does not collapse to zero while using Monte Carlo algorithm, thus, maintaining a certain level of accuracy in the results of the simulations.

¹¹ `fmincon` in MATLAB.

4. The Bates Model for CoCo Valuation

4.1.1 Modified Option Pricing (FFT)

Now, the point is how to determine the pricing formula of the options. Due to the lack of a closed-form solution in case of models different from the Black-Scholes one, a quasi-closed formula can be derived, starting with the definition of the model characteristic function. In particular, given the fact that the SVJ model is made by two sub-models, Stochastic Volatility (SV) model and Black-Scholes Jump Diffusion (BSJ) model, its characteristic function $\phi(u)$ is made by two components: the characteristic function $\phi_{SV}(u)$ of Heston (1993) and $\varphi_J(u)$, the adjustment for the jumps.

Let u be a grid of values to evaluate the function and i the imaginary part of a complex number, then the characteristic function of the random variable $x_t = \log(S_t)$ is

$$\phi(u) = \phi_{SV}(u) \cdot \varphi_J(u), \quad (4.3)$$

given

$$\begin{aligned} \phi_{SV}(u) &= \mathbb{E}[\exp(iux_t) | \log(S_0) = x_0, v_0] \\ &= \exp \left[iu(x_0 + (r - q)t) + \left(\frac{2\zeta(1 - e^{-\theta t})}{2\theta - (\theta - \gamma)(1 - e^{-\theta t})} \right) \cdot v_0 \right. \\ &\quad \left. - \frac{\kappa\eta}{\lambda^2} \left[2\log \left(\frac{2\theta - (\theta - \gamma)(1 - e^{-\theta t})}{2\theta} \right) + (\theta - \gamma)t \right] \right], \end{aligned} \quad (4.4)$$

where

$$\begin{aligned} \zeta &= -\frac{1}{2}(u^2 + iu) \\ \gamma &= \kappa - i\rho\lambda u \\ \theta &= \sqrt{\gamma^2 - 2\lambda^2\zeta} \end{aligned}$$

and

$$\varphi_J(u) = \exp[\lambda_J t [(1 + \mu_J)^{iu} \exp(\zeta \sigma_J^2) - 1 - iu\mu_J]], \quad (4.5)$$

The valuation of European call options requires that the density function of the stock is known (in the risk-neutral environment \mathbb{P}) and the characteristic function is used to obtain an easier representation of the call price itself.¹² However, the formula (herein given) includes an integral, which does not allow an exact computation and it is the reason why we need to use a numerical approximation. One of these method is developed by Carr and Madan (1999). They propose a modified call-price method that applies the Fast Fourier Transform (FFT) algorithm.

Fourier Transform \mathcal{F} :

¹²I.e. Kwok et al. (2012).

4. The Bates Model for CoCo Valuation

Given a piecewise continuous and integrable function $f(x)$, its Fourier Transform corresponds to

$$\mathcal{F}[f(x)] = \int_{-\infty}^{+\infty} e^{iux} f(x) dx = \phi(u). \quad (4.6)$$

It follows that its inverse \mathcal{F}^{-1} is

$$\mathcal{F}^{-1}[\phi(u)] = \frac{1}{2\pi} \int_{-\infty}^{+\infty} e^{-iux} \phi(u) du = f(x). \quad (4.7)$$

Thus, the characteristic function can be expressed in terms of the Fourier Transform¹³ of the density function, i.e.

$$\phi(u) = \mathbb{E}[e^{iux}]. \quad (4.8)$$

Under the risk-neutral measure \mathbb{P} , the stock density function is $f(x)$, therefore $\phi(u)$ is its characteristic function. Under the Bates model, the former has not a closed form. However, if it exists its characteristic function, we can rely on the Fourier Transform (and its inverse).

Carr and Madan (1999) find an efficient way to simplify the computation of the price of an European call option.

Let the present value of the payoff of an European call option with maturity T and strike K , be expressed as

$$\begin{aligned} C_T(k) &= \mathbb{E}_t[e^{-r(T-t)} \text{Payoff}_{Call}] \\ &= e^{-rT} \int_k^{+\infty} (e^{x_T} - e^k) f_T(x_T) dx_T, \end{aligned} \quad (4.9)$$

in which

$$x_t = \log(S_t),$$

$$k = \log(K), \text{ is the strike price,}$$

$$f_T(x) \text{ is the density function of } x_T \text{ under } \mathbb{P}.$$

Due to the fact that 4.9 is not square integrable,¹⁴ Carr and Madan (1999) give the definition of a modified call price function, in order to apply the FFT algorithm.

$$c_T(k) = e^{(\alpha k)} C_T(k). \quad (4.10)$$

The immediate consequence is the fact that 4.10 is now square integrable for $\forall k$ and for some positive reasonable values of the *damping factor* α . Thus, we can apply 4.6 and 4.7 to equation 4.9 and after some algebraical steps,

$$\begin{aligned} C_T(k) &= e^{-\alpha k} c_T(k) \\ &= e^{-\alpha k} \frac{1}{\pi} \int_0^{+\infty} e^{-izk} \psi_T(z) dz. \end{aligned} \quad (4.11)$$

¹³It is true for absolutely continuous random variables x , namely for random variables with a density function.

¹⁴For more details see Carr and Madan (1999).

4. The Bates Model for CoCo Valuation

This is the price of a European call option with strike K and maturity T , where $\psi_T(z)$ is the Fourier Transform of c_T :

$$\begin{aligned}
 \psi_T(z) &= \int_{-\infty}^{+\infty} e^{izk} c_T(k) dk \\
 &= \int_{-\infty}^{+\infty} e^{izk} e^{\alpha k} e^{-rT} \int_k^{+\infty} (e^{x_T} - e^k) f_T(x_T) dx_T dk \\
 &= \int_{-\infty}^{+\infty} e^{-rT} f_T(x_T) \int_{-\infty}^{x_T} (e^{x_T + \alpha k} - e^{(\alpha-1)k}) e^{izk} dk dx_T \\
 &= \frac{e^{-rT}}{\alpha^2 + \alpha - z^2 + i(2\alpha + 1)z} \int_{-\infty}^{+\infty} e^{(\alpha+1+iz)x_T} f_T(x_T) dx_T \\
 &= \frac{e^{-rT}}{\alpha^2 + \alpha - z^2 + i(2\alpha + 1)z} \int_{-\infty}^{+\infty} e^{(-\alpha-i+z)x_T} f_T(x_T) dx_T \\
 &= \frac{e^{-rT} \phi_T(z - (\alpha + 1)i)}{\alpha^2 + \alpha - z^2 + i(2\alpha + 1)z},
 \end{aligned} \tag{4.12}$$

It is obtained¹⁵ substituting 4.9 and 4.10 into $\psi_T(z)$ and using $\phi_T(u)$ equal to the characteristic function of the Bates model, equation 4.3.

Finally, equation 4.11 can be rewritten, thanks to the use of the FFT algorithm and the Trapezoid rule for the integral on the right side.¹⁶

Defying the FFT algorithm¹⁷ as

$$w(k) = \sum_{j=1}^N e^{-i\frac{2\pi}{N}(j-1)(k-1)} x(j), \quad k=1,2,\dots,N; \tag{4.13}$$

the price of the European call option becomes

$$C_T(k_y) \approx \frac{e^{-\alpha k_y}}{\pi} \sum_{j=1}^N e^{-i\Delta z \Delta k (j-1)(y-1)} e^{ibz_j} \psi_T(z_j) \Delta z, \tag{4.14}$$

with

$$b = \frac{N\Delta k}{2}, \text{ is the boundary condition for } k,$$

$$k_y = -b + \Delta k(y - 1), \quad y=1, \dots, N.$$

For what concern the parameters Δk and Δz , the authors set the condition such that, said $N = 4096$ and a small step of grid of integration Δz

$$\Delta k \Delta z = \frac{2\pi}{N}.$$

¹⁵ $e^{(\alpha+1+iz)x_T} = e^{iux_T}$.

¹⁶ See Carr and Madan (1999) for the derivation.

¹⁷ N is usually a power of two.

4. The Bates Model for CoCo Valuation

Hence, in order to obtain an accurate integration for a large Δk , that is a consequence of a small Δz , Carr and Madan (1999) introduce the Simpson's rule:

$$C_T(k_y) \approx \frac{e^{-\alpha k_y}}{\pi} \sum_{j=1}^N e^{-i \frac{2\pi}{N} (j-1)(y-1)} x(j), \quad (4.15)$$

in which

$$x(j) = e^{ibz_j} \psi_T(z_j) \frac{\Delta z}{3} (3 + (-1)^j - \delta_{j-1}),$$

and δ_j is the Kronecker delta.¹⁸

Once N and Δz are chosen, the remainder parameter to be set is α . Carr and Madan (1999) develop this kind of analysis for call options only. Later, with the works of Lee (2004) and Schmelzle (2010), a proper study of the *damping factor* is implemented. Looking at equation 4.12, α is the parameter that ensures the integrability of equation 4.11. For a call option, it must be $\alpha > 0$ and Schmelzle (2010) explains how the call value changes according with it. Moreover, Lee (2004) shows how this value must satisfies $\mathbb{E}[S_T^{\alpha+1}] < +\infty$ and hence $\phi_T(-(\alpha+1)i) < +\infty$. Then, he shows how the damping factor can be modified according to what type of option is considered. For instance, in case of a put option the FFT can be easily applied by setting $\alpha < -1$.

The thesis takes into account three types of European options: call, put and digital put and the levels of α are explains in section 5.2.1. However, regarding the last option type, the Fourier Transform $\psi_T(z)$ changes according with the different payoff. Hence, in order to evaluate binary put options, α is set lower than zero and the Fourier Transform of $c_T(k)$ becomes¹⁹

$$\psi_T(z) = \frac{e^{-rT} \alpha \phi_T(z - i\alpha)}{|\alpha|(\alpha + iz)}. \quad (4.16)$$

4.2 Monte Carlo Simulations

After the calibration, the resulting model can be applied to the pricing model of the CoCo bonds. However, under the assumption of a stochastic volatility, such as the case of the Bates model, it is impossible to find closed-form solutions for components B and C of equation 3.3. Therefore, the price of a CoCo bond is obtained through numerical simulations (Monte Carlo).

¹⁸The MATLAB code is based on an equivalent formulation of 4.15 made by Moodley (2005) and implemented using `fft(x(j))`, such that j -th option has a strike price $K = \exp\left(-b + \frac{2b}{N}(j-1)\right)$.

¹⁹Financial CAD Corporation - "FINCAD" (2008), Option Pricing with the Heston Model of Stochastic Volatility, available online: <http://www.fincad.com>

4. The Bates Model for CoCo Valuation

Monte Carlo algorithm requires several steps that are repeated for M (reasonable big number) times.

Monte Carlo Algorithm:

1. First, a discretization method is chosen (as in the next paragraph), in order to make the simulation in a discrete-time grid.
2. For each of the M simulations the paths of both the stock and the volatility are computed.
3. The i -th payoff is evaluated: at maturity T , the payoff corresponds to the payoff of a coupon bond. Otherwise, if the i -th stock price falls below the trigger level S^* , the payoff of the CoCo bond at conversion behaves like a portfolio of barrier options that hit the barrier level.
4. Finally, the average of the present values gives back the estimate (result) of Monte Carlo simulations,

$$\hat{P}_{CoCo,M} = \frac{1}{M} \sum_{i=1}^M \hat{P}_{CoCo,i}.$$

It can be proved that $\hat{P}_{CoCo,M}$ is an unbiased estimator (it converges to the true value when M is sufficiently big using the central limit theorem) and thus, the distribution of the estimation-error is approximately normal.²⁰

4.2.1 Quadratic Exponential Scheme

In order to work out the algorithm, the processes in equation 3.9 must be discretized. The general approach is the Euler scheme. However, according to Broadie and Kaya (2006), it produces a bias error that requires a high number of iterations to be reduced. In order to achieve a faster order of convergence to the true value with Monte Carlo simulations, I apply the Quadratic Exponential (QE) algorithm of Andersen (2008). In the Quadratic Exponential scheme, the stochastic volatility has approximately a non-central chi-squared distribution, obtained through moment-matching its mean and variance.

The algorithm follows Kienitz and Wetterau (2012).²¹ Here again, the stock-price process is considered in terms of $x_t = \log(S_t)$ and a switching rule is used to evaluate low

²⁰More details in Spiegeleer et al. (2014).

²¹The MATLAB code is inspired by their formulation of the QE scheme algorithm for the Bates model, which is provided online: <https://it.mathworks.com/matlabcentral/fileexchange>

4. The Bates Model for CoCo Valuation

and high level of the stock variance, in order to manage its distribution behaviour in the Monte Carlo simulations.

QE scheme:

1. Compute the first and the second moments of the stochastic volatility

$$m = \eta + (v_t - \eta)e^{-\kappa\Delta t}$$

$$s^2 = \frac{v_t\lambda^2 e^{-\kappa\Delta t}}{\kappa}(1 - e^{-\kappa\Delta t}) + \frac{\eta\lambda^2}{2\kappa}(1 - e^{-\kappa\Delta t})^2;$$

2. Compute $\psi = \frac{s^2}{m^2}$;
3. Draw $U_v \sim U(0, 1)$, from a uniform distribution;
4. Set an arbitrary critical level $\psi_C \in [1, 2]$ to let $v_{t+\Delta t}$ moment-match the real Chi-square distribution;
5. *Switching Rule*

- if $\psi \leq \psi_C$, use a non-central χ^2 distribution for the moment-matching approximation, by setting

$$v_{t+\Delta t} = a(b + z_1)^2, \text{ with}$$

$$b^2 = 2\psi^{-1} - 1 + \sqrt{2\psi^{-1} - 1} \sqrt{2\psi^{-1} - 1} \geq 0$$

$$a = \frac{m}{1 + b^2}$$

$$z_1 \text{ drawn from } Z_1 \sim N(0, 1);$$

- if $\psi > \psi_C$, use instead an exponential distribution for the moment-matching approximation, by setting

$$v_{t+\Delta t} = \psi^{-1}(u; p, \beta), \text{ with}$$

$$p = \frac{\psi - 1}{\psi + 1}$$

$$\beta = \frac{1 - p}{m}$$

$$\psi^{-1}(u) = \psi^{-1}(u; p, \beta) = \begin{cases} 0, & \text{if } 0 \leq u \leq p; \\ \beta^{-1} \log\left(\frac{1-p}{1-u}\right), & \text{if } p < u \leq 1 \end{cases};$$

6. Add the jump component by first generating P from a Poisson distribution with parameter $\lambda_J \Delta t$ and then computing $\log(1 + J) = \mu_J P + \sigma_J \sqrt{P} w$, given w a random value from $W \sim N(0, 1)$;

4. The Bates Model for CoCo Valuation

7. Generate z_2 drawn from $Z_2 \sim N(0, 1)$, and finally compute the log-stock path as follow.

$$x_{t+\Delta t} = x_t + K_0 + K_1 v_t + K_2 v_{t+\Delta t} + \sqrt{K_3 v_t + K_4 v_{t+\Delta t}} z_2, \quad (4.17)$$

with

$$K_0 = -\frac{\rho \kappa \eta}{\lambda} \Delta t$$

$$K_1 = \gamma_1 \Delta t \left(\frac{\rho \kappa}{\lambda} - \frac{1}{2} \right) - \frac{\rho}{\lambda}$$

$$K_2 = \gamma_2 \Delta t \left(\frac{\rho \kappa}{\lambda} - \frac{1}{2} \right) + \frac{\rho}{\lambda}$$

$$K_3 = -\gamma_1 \Delta t (1 - \rho^2)$$

$$K_4 = -\gamma_2 \Delta t (1 - \rho^2)$$

and γ_1, γ_2 arbitrary values for prediction correction.

Andersen (2008) suggests a critical level, ψ_c , equal to 1.5. In addition, the prediction correction, through γ_1 and γ_2 , is used for the level of accuracy during the drift interpolation to obtain the sampling of the log-stock price. γ_1 and γ_2 are chosen such that $\gamma_1 + \gamma_2 = 1$.²²

4.2.2 Variance Reduction

Spiegeleer et al. (2017) suggest a Monte Carlo simulation based on 5 million trials, in order to improve the precision in the valuation of the CoCo bonds. Unfortunately, the computation is very time consuming. Therefore, some techniques to reduce the variance of the simulations can be applied.

Moment Matching

According to Hull (2014), the moment matching is one of the variance reduction techniques used to save the time of the computation. The QE scheme is based on this approach. It uses mainly the first and the second moments to adjust the samples generated from a standard normal distribution. Let m and s^2 be respectively the mean and the variance of the sample x_i , for $\forall i \in [1; M]$. Then, the moment-matching generates the adjusted sample x_i^* , such that

$$x_i^* = \frac{x_i - m}{s}.$$

²²Here, it is assumed $\gamma_1 = \gamma_2 = 0.5$.

4. The Bates Model for CoCo Valuation

Antithetic Variable Technique

The antithetic variance technique achieves to keep a reasonable level of accuracy. The method is explained in details by Hull (2014). The main concept is to generate two values of the CoCo payoff in each simulation, such that the first value, $\hat{P}_{CoCo,1,i}$, is the result of the i -th Monte Carlo simulation and the second value, $\hat{P}_{CoCo,2,i}$, is obtained by switching the sign of the random value from the standard Normal distribution. Finally, the result of the i -th simulation is the average $\bar{P}_{CoCo,i}$

$$\bar{P}_{CoCo,i} = \frac{\hat{P}_{CoCo,1,i} + \hat{P}_{CoCo,2,i}}{2}.$$

Given M simulations and the antithetic variance approach, it can be proved that the standard error of the final estimate is lower than the standard error of the estimate obtained running the same Monte Carlo algorithm for $2M$ times.

Consequently, the analysis in this thesis is implemented using Monte Carlo trials and the Antithetic Variable approach in conjunction with the Moment Matching, included in the QE scheme. Indeed, with the former, the odd moments automatically correspond, thus, the latter needs to match only the second moment, saving computation time.

5 Case Study: Barclays CoCos

Today, Barclays PLC is a British international bank and it is recovering from the recent financial crisis. Restructuring its business, the health of the bank is improved: "the Group is smaller, safer, more focused, less leveraged, better capitalized and highly liquid, with the customer at the center of the business" (Barclays PLC, Annual Report 2016 - *Chairman's letter*). The CET 1 Ratio, 12.4% in 2016, has reached the level of 12.5% during the first quarter of 2017. The shareholders' equity is also increased, being GBP 58.4bn as at the end of 2016. Figure 5.1 represents the path of Barclays daily-stock prices over 10 years, expressed also in terms of log-returns. The latter ones are used to obtain the Q-Q Plot, such that it is evaluated the difference in the quantiles of their cumulative distribution with respect to the ones of a standard normal distribution. Figure 5.2 shows that the Barclays log-returns can not be considered log-normally distributed, reinforcing the choice to deviate from the Black-Scholes assumptions.

Figure 5.1: Daily Close-Adjusted Stock Prices (GBP) and Log>Returns of Barclays PLC from 24 March 2007 to 24 March 2017

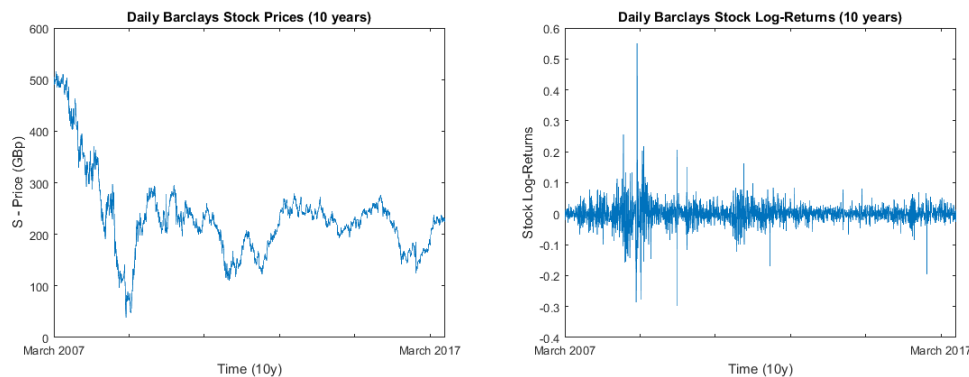

5.1 The Dataset

The data used for the analysis are obtained from Bloomberg. They can be divided in two parts: the first mainly comprises the information about the CoCo bonds issued by Barclays PLC. The other includes the option dataset needed for the calibration of the Bates model.

5. Case Study: Barclays CoCos

Figure 5.2: Q-Q Plot - Comparison of the Quantiles of the Barclays Stock Prices versus the Standard Normal Quantiles

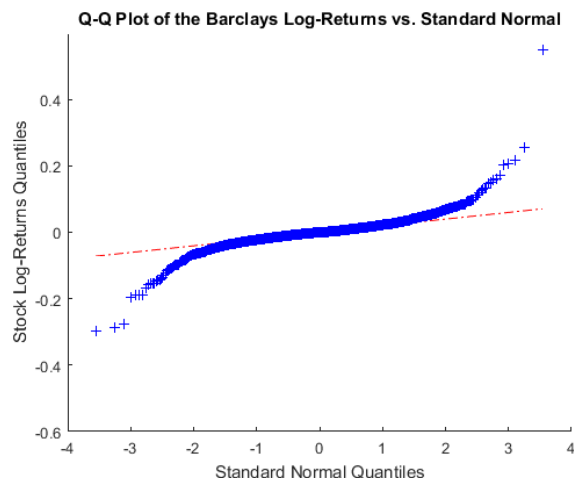

The valuation of the CoCo bonds is made on a single date, therefore all the data refer to the 24th March 2017.

CoCo Dataset

On the valuation date, Barclays has 10 contingent convertible bonds on the market. All of them share an accounting trigger level linked to the CET1 Ratio, that is set at 7%. For the analysis two categories of CoCos are considered.

First, I take into account 3 of the AT1 CoCos, that are denominated in USD. For the category of capital they belong to, they are designed as perpetual CoCos. At the trigger date, they are fully converted into shares for a fixed conversion price. The Prospectus²³ of Barclays provides all the information about the coupon payments and C_P , fixing also the exchange rate GBP/USD. The coupon payments are quarterly and due to the fact that they are perpetual CoCos (i.e. $T = +\infty$), I assume that their maturities are their first call dates.²⁴ The choice is made due to the complex structure of this category of CoCos. First of all, the valuation of the implicit barrier options, considered without predefined maturities, requires a modification of the whole Equity Derivative model, making it more complex.²⁵

²³<https://www.home.barclays/prospectuses-and-documentation/capital-securities-documentation/tier1-securities.html>

²⁴For this analysis I recover the example made in Spiegeleer et al. (2014), in which the comparison between AT1 and T2 CoCos is made by approximating the maturity of the CoCo with the first call date.

²⁵Despite the complexities, according to Spiegeleer et al. (2014) the model is designed to be an easier approach to price CoCos than the structural models. Adding other sources of risks or modifying the model

5. Case Study: Barclays CoCos

Consequently, the possibility to call back the CoCo bonds and the related extension risk are not taken into account in this analysis as well as the variation of the coupon rate after the first call date. Indeed, they are paid out adding the Mid-Market Swap Rate to a fixed interest percentage, as established in the Prospectus.

Secondly, I select the two Barclays CoCos based on TIER 2. They do not share the same loss-absorbency mechanism, since at conversion the holder faces a permanent full write-down. They also have fixed maturities and semiannually coupon payments. Only one of them has the call-back feature. Therefore, in this case the maturity is again considered equal to the first call date, while for the other one (non-callable CoCo), it is used the real maturity.

Table 5.1 includes the details about the CoCo-dataset. For the analysis, all the data are converted into GBP (Pence Sterling) and some assumptions are made, e.g. the accrued interest is dropped, according to the Equity-Derivative-model formulation of Spiegeleer et al. (2017). The calculations are made on a nominal amount of the CoCos of 100 GBP and their prices refer to the mid prices observed in Bloomberg,²⁶ as a percentage of the face value.

Table 5.1: Barclays PLC CoCos - 24th March 2017

USD AT1 CoCos						
	ISIN	Price	Cpn %	1 ST Call Date (Maturity, T)	C_P	GBP/USD (fixed for C_P)
1	US06738EAB11	99.242	6.625	15/09/2019	2.77	167.69
2	XS1481041587	104.22	7.875	15/03/2022	1.99	132.34
3	US06738EAA38	105.25	8.25	15/12/2018	2.64	160.26

USD T2 CoCos					
	ISIN	Price	Cpn %	1 ST Call Date (Maturity, T)	Full Write-Down
4	US06740L8C27	109.08	7.625	21/11/2022	$C_r = 0$
5	US06739FHK03	105.10	7.75	10/04/2018	$C_r = 0$

For the application of the pricing models, additional data are needed. First, the risk-free rate, r , is kept constant and it is estimated through a 10-year UK Government bond, formulation, as it is required by the case with perpetual CoCos, will make the model less easy to handle and less intuitive.

²⁶Dirty Prices.

5. Case Study: Barclays CoCos

such that $r = 1.47\%$. Secondly, the dividend yield of Barclays is assumed to be equal to $q = 2.52\%$. The values are obtained from the Bloomberg data, considering a period of time of two years and referring to an annual basis. Finally, the stock mid-price of Barclays, S_0 , is 226.65 GBP and the estimated stock volatility is 39.38% on annual basis. The latter one is used as Black-Scholes volatility σ_{BS} , in order to implement the original formulation of the Equity Derivative model.

Option Dataset

The other part of the dataset includes OTM plain-vanilla call and put options and the CDS spreads of Barclays, available on the valuation date. OTM options are needed in the calibration, in order to obtain parameters that are aligned with the CoCo structure. The CoCo behaves as a down-and-in put option for its holder. Consequently, the CDS term structure reflects the CoCo long maturity and its sensitivity to down-side risk, while OTM options convey that the CoCo, expressed in terms of barrier options, is not on the point of being triggered (hitting the barrier level).

The plain-vanilla options are chosen with a maturity of less than a year and with different strike prices. The fact that most of the option prices are not very liquid in the market brings some issues when they are used for the analysis. In a first attempt, the mid prices of 164 European plain-vanilla options have been used. Then, a screening of those options has been obtained by removing the ones with a bid price equal to zero and, in case of two options with same maturity and same strike price, removing the ones with a higher bid-ask spread. Hence, the total number of the plain-vanilla options has decreased to 151 and their mid prices have been replaced by the last prices. The choice follows the fact that on average the latter ones are closer to the option prices obtained using the available Implied Volatilities (from Bloomberg) in the Black-Scholes formula.²⁷ Below, the implication of the choice of different data is explained in terms of calibration results.

This thesis considers the subordinated CDS with a recovery rate of 20%, due to the fact that all the CoCo bonds used for the analysis have the same recovery-rate level set at 20%.

²⁷Using $\sigma = IV$, it follows that the price of a call option is

$$C_0 = S_0 e^{-qT} \Phi(d_1) - K e^{-rT} \Phi(d_2)$$
$$\text{with } d_1 = \frac{\log(S_0/K) + (r - q + \sigma^2/2)T}{\sigma\sqrt{T}}$$
$$\text{and } d_2 = d_1 - \sigma\sqrt{T},$$

while the put option price is equal to $P_0 = C_0 + K e^{-rT} - S_0 e^{-qT}$ (Hull, 2014).

5. Case Study: Barclays CoCos

The subordinated term structure of CDS of Barclays PLC is made by seven Credit Default Swap and the spreads available on the market at the valuation date are used, together with their maturities that go from 1 to 10 years. The CDS spreads are used to compute the prices of deep OTM digital put options, which are not available in the market considering such long maturities. The prices of those options are easily obtained following the heuristic way given by Spiegeleer et al. (2017).

The Heuristic Way

In case of default the payoff of a zero-recovery CDS is equal to the payoff of a binary put option, due to the fact that the default is seen as the moment in which the stock price falls below a low strike. Thus, the upfront of the zero-recovery CDS is considered the price of the binary put option, under the assumption of a fixed strike price of 15% of the stock price, obtaining one option for each CDS. Thus, the upfront of the Credit Default Swap is calculated and then rescaled to a zero-recovery CDS upfront.²⁸

The calculation of the default intensity is given in details in appendix A.1. Here, it is assumed that it is deterministic (piecewise constant) and it is bootstrapped from the market CDS spreads. Next, it is used to calculate the survival probability, $F(t_i)$, with quarterly coupon payments; finally the upfront payment for the CDS with maturity T equals:

$$UP = cs \cdot \frac{1}{4} \sum_{i=1}^{4T} e^{-rt_i} (1 - F(t_i)), \quad (5.1)$$

where cs is the CDS spread observed in the market and $(1 - F(t_i))$ is the default probability at time t_i . Consequently, the upfront payment is rescaled to an upfront payment of a zero-recovery CDS, in order to obtain the payoff of a deep OTM digital put option, P ;

$$P = \frac{UP}{(1 - \pi)}, \quad (5.2)$$

with $\pi = 0.2$ (recovery-rate).

The resulting option dataset is made of 158 elements and it is divided in the Equity Data Group (EDG) with 151 plain-vanilla options and the CDS Data Group (CDG) including 7 digital put options. They are represented in Figure 5.3 as a function of the maturity (T) and the strike price (K). The EDG ('o') includes the OTM European plain-vanilla call and put options, with a maturity lower than one year, meanwhile the CDG-options ('*') has a strike price of 15% of the stock price (226.65 GBp) and longer maturities.

²⁸See also Corcuera et al. (2013).

5. Case Study: Barclays CoCos

Figure 5.3: Available Option Data in terms of maturity (T) and the strike price (K)

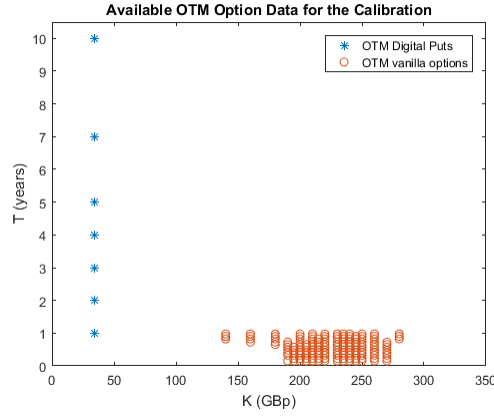

5.2 Calibration Results

Using the option dataset, the calibration is done applying the FFT, in order to use a quasi-closed form for the price of the options and the Nelder-Mead algorithm for the optimization.

Recalling equation 4.1, different weights are given to the option dataset. Options with longer maturities receive higher weights, adapting the model parameters to the structure of the CoCo bonds. The weights sum up to the unity. Each option group, EDG and CDG, receives a total weight of 0.5. Then, the options in the EDG are weighted as follow:

$$w_i = 0.5 \frac{1}{151}.$$

The deeper OTM the CDG options are, the more weight they receive, according to the rule:

$$w_i = 0.5 \frac{2^i}{\sum_{k=1}^7 2^k}, \quad i = 1, 2, \dots, 7$$

The result of the optimization of the 7 parameters and one state variable, v_0 , is given in Table 5.2, achieving a w-RMSE equal to 0.6346. The initial value of the variance path, v_0 , is reported as standard deviation, $\sqrt{v_0} = \sigma_0$. Then, Figure 5.4 shows the fit of the calibration, by comparing the market prices ('o') of the option dataset with the model prices ('+'). The available data, plain-vanilla and binary put options respectively, create a high concentration with a high peak around $K = S_0$ and a big left-tail.

On the one hand, the results show how this kind of calibration, without any additional assumption on the parameters, produces a high w-RMSE. Therefore in order to match the model prices with the market prices, the resulting parameters are *forced* to assume values that might not be very reasonable. For instance, the speed of mean reversion, κ , is very

5. Case Study: Barclays CoCos

Table 5.2: Calibration of the Bates Model - Resulting Parameters

κ	η	λ	ρ	σ_0	λ_J	μ_J	σ_J
4.6048	0.0031	0.1189	-0.4695	0.1819	1.1018	-0.1399	0.2772

Figure 5.4: Calibration of the Bates model - Comparison between the Model Prices and the Market Prices



high. It means that there is a fast convergence of the stochastic variance to its long-term mean, η , which is at a very low level. Both the latter parameter and the initial value of the variance are far from the stock variance used for the Black-Scholes case ($0.3938^2 = 0.155$). Furthermore, the size of the jumps is also very high, causing huge changes in the stock prices. Thus, the stock path is characterized by a stochastic volatility mostly around the long-term mean value and sudden big jumps.

On the other hand, the resulting parameters prove the existence of a negative correlation between the stock and its volatility and negative jumps of the stock prices, that indeed enforce the asymmetry of the volatility smile on the left side.

5.2.1 The Damping Factor

In order to implement the calibration and be able to apply the FFT in equation 4.15, I need to set the value of the damping factor α , as explained in the previous chapter. Equations 4.12 and 4.16 are respectively used for the plain-vanilla and the binary put options. Recalling the restrictions of the damping parameters (section 4.1.1), I select a different value for any class of options, such that the w-RMSE is the lowest among several trials and the results

5. Case Study: Barclays CoCos

of the calibration are the most reasonable. The choice to set α arbitrarily is because an optimization in terms of 9 input-values is less accurate and more time consuming. Table 5.3 summarizes the values used for the analysis.

Table 5.3: Values of the Damping Factor

Option Class	α	Boundary Condition
Call	0.75	$\alpha > 0$
Put	-1.5	$\alpha < -1$
Binary Put	-0.5	$\alpha < 0$

Changing the damping factor differently affects the results. Other trials with different α are described in details in appendix A.2, together with the calibration results obtained in the first attempt with the option mid prices.

5.2.2 Implied Volatility Surface

With the Bates parameters, it is possible to outline the shape of the volatility surfaces of the option dataset. Figure 5.5 shows the implied volatility for each class of options, as a function of the strike prices and the maturities. The surfaces are obtained with the assumption of the current stock price S_0 , a sample of maturities from 0.3 to 3 years and strike prices in a range of [181;271] GBP. Then, the prices of the options are computed with the Bates model and used to calculate the Black-Scholes implied volatilities.²⁹ The data are summarized below, while the parameters of the Bates model are recovered from Table 5.2.

Table 5.4: Data of the Implied Volatility Surfaces of different Option Classes

S_0	K	T
226.65	[181;271]	[0.3;3]

The results in Figure 5.5 demonstrates how the Black-Scholes assumption for the stock volatility does not fit the data observed in the market. For instance, binary put options have a flatter volatility surface than the plain-vanilla put. Thus, a stochastic volatility is able to create a more market-conform volatility skew, capturing the peculiarities of the data, in terms of option class, maturity and strike price. Then, the presence of the jumps allows to capture volatility variations also for short maturities. Even though, the volatility surfaces

²⁹`b1simp` in Matlab.

5. Case Study: Barclays CoCos

Figure 5.5: Implied Volatility Surface under the Bates Model with respect to different Option Classes

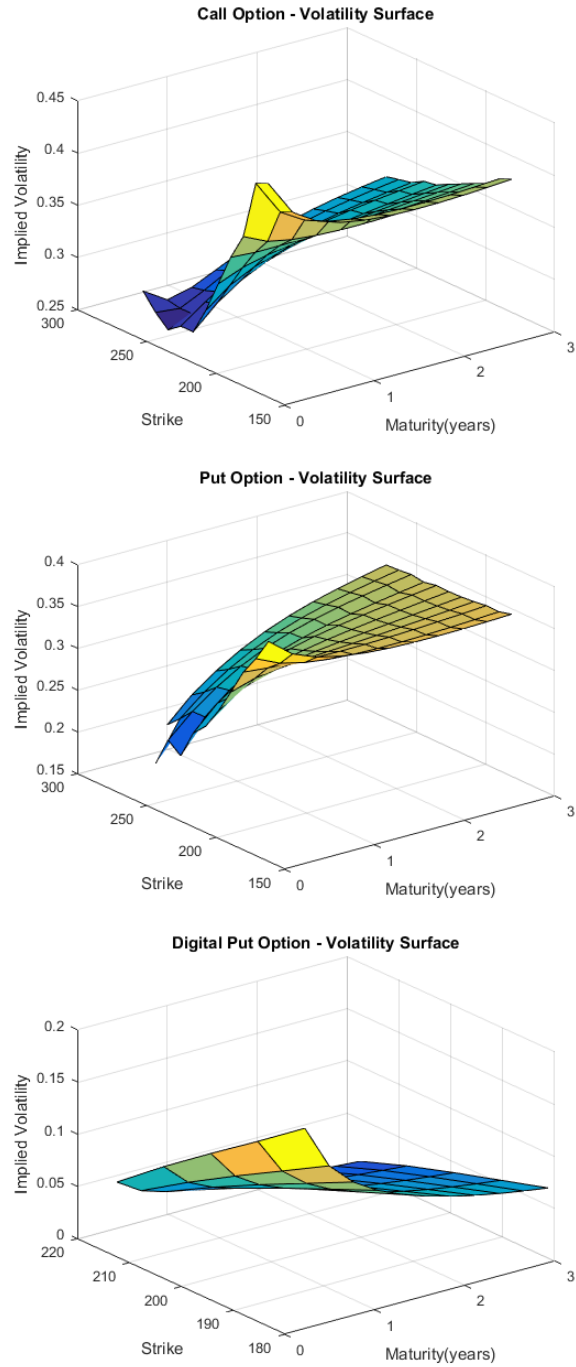

5. Case Study: Barclays CoCos

differ from each other, a common result is in the peak for maturities of less than a year and strike prices that are far from the stock price. In the case of binary put options and for a fixed low strike value, the volatility smile with respect to the maturity is steeper than for the plain-vanilla classes, while the put-option case is the flatter, reaching smaller levels of IV for shorter maturities. Next, keeping fixed the maturity to a low level and looking at the volatility smiles with respect to the strike prices, the binary-put case is almost linearly decreasing, while the other two cases are more indented. In this case, the steepest case is the one of plain-vanilla call.

5.3 Implied Barrier of the CoCos

In order to simplify the notation, I use the form *Bates-ED* to recall the Equity Derivative model implemented with the Bates stock path and *BS-ED* for the original formulation of the model with the Black-Scholes assumption.

The Equity Derivative approach is used to price the contingent convertible capital, which are issued with an accounting trigger, using the stock price as market trigger. However, the relation between the CET 1 Ratio and S^* is not given explicitly. Thus, the price is obtained by applying the model with the assumption of a reasonable implied market trigger, S^* . Another way to infer the price is to use the model to match the price with the market price and calculate S^* . Doing this way, the prices of the CoCos are analyzed indirectly, checking if the market prices are fair prices for the CoCos of the same financial institution. Theoretically, S^* should be the same for all the CoCos that share the same accounting trigger. Therefore by looking at S^* , it is possible to detect if there exists an over- or undervaluation of the contingent capital (Spiegeleer et al., 2017).

Following this second approach, the Bates-ED model is applied in order to compare the results in terms of S^* and the trigger probability with the BS-ED model. Thus, the impact of two additional features (SV and jump in the stock prices) is analyzed. The lack of a closed-form solution for the Bates-ED model requires the use of Monte Carlo simulations. The application is done in two steps. The first one achieves the simulation of the stock price and its stochastic volatility, under the Bates model. In the second step, the payoff of a CoCo bond is evaluated checking whether the stock price reaches the barrier level. If this does not happen, the CoCo price equals the present value of its host instrument (i.e. the coupon bond), otherwise its payoff is computed recovering equations 3.2 and 3.4.

Monte Carlo simulations are run for $M = (5 \cdot 10^4)$ times³⁰ and the maturity of the CoCo

³⁰Unfortunately, the big size of the matrices does not allow to set M to higher values in order to let MATLAB

5. Case Study: Barclays CoCos

bond is discretized using $m = 2500$ steps. Due to the complexity of the problem, Monte Carlo algorithm simulates the price of the CoCo bond for a range of barrier levels, $S^* \in [30; 150]$. Once the model prices are obtained, the implied barrier level is found such that the model price (Bates-ED) and the market price of the CoCo coincide.³¹ The same range of market triggers is used to compute the BS-ED model price (using the closed-form of the Equity Derivative model). Finally, the results of the two models are compared looking at the implied market trigger and the related conversion probability. As the market trigger increases, becoming closer to the current stock value S_0 , it is more likely that the CoCo bond is triggered. More precisely, it is the stock price that varies with the time, being S^* fixed. If S_0 is placed next to the market trigger, it is reasonable to expect that also small (negative) changes in the stock price will trigger the CoCo. Thus, as the difference between the current stock price and S^* shrinks, the conversion probability increases.

5.3.1 AT1 CoCo: Case of a Full Conversion

First, the analysis focuses on the AT1 CoCo bonds. A graphical representation is provided by Figure 5.6, in which the prices of the two versions of the Equity Derivative model are represented with respect to S^* . The market price is given as a straight line. The solution in terms of the implied market trigger is found when the model-price curve intersects the market-price line. The trigger probability increases with the increase of the market trigger, being closer to the current stock price S_0 (placed on the right side of the graphs). In the light of this, a detailed explanation of Figure 5.6 is given below.

First, I focus on the results in terms of S^* , which are summarized in Table 5.5. Even though the CoCos share the same accounting trigger level (CET 1 Ratio $\leq 7\%$), not only the Equity Derivative models do not reproduce the same market trigger level for all of them, but in some cases they never give back a model price that matches with the market price. For the BS-ED model, only for the second CoCo bond it does not exist a solution in terms of S^* , while for the Bates-ED model none of the market prices seem to be fair with respect to the model prices. In this perspective, the results of the Bates-ED model suggest that this kind of CoCos would never be triggered, for any market trigger level. However, we know that indeed there exists an accounting trigger, for which the conversion happens irrespective of the results of this model. In addition, a comparison can be done by looking at the BS-ED case. This model provides some solutions in terms of S^* . Hence, it might be more suitable work.

³¹Due to the fact that the simulations are done only for integer values of S^* , the resulting barrier level corresponds to the closest model price to the market price.

5. Case Study: Barclays CoCos

for the pricing of AT1 CoCos, even considering the exception of the second CoCo bond, which has a market price lower than the model price.

Looking at the BS-ED only, in order to conclude that the No.2 CoCo is a good investment, detecting a favorable opportunity for the holder and a possible mis-pricing in the market, first it must be proved that the model is a good method to price AT1 Barclays CoCos. Nevertheless, with the limited information of the three CoCos, it is hard to come to such a conclusion. Limited to the analysis of the other two CoCos in the Black-Scholes case, for which a solution exists, it can be only observed that they have barrier levels that do not coincide, as shown in Table (5.5) and the difference between the two levels of S^* is approximately of 14.22%.

Coming to the case of the Bates-ED model, the lack of solutions can be affected by several factors. The model-price curves are higher than the market price for any S^* . Therefore the model seems to overestimate the price of the CoCos. The reasons can be several. First of all, the shorter maturity can affect the model price, due to the fact that this approach evaluates the trigger probability only up to the first call date. Indeed after that, the face value is assumed to be paid back to the holder. From a financial point of view, the sequence of payments (coupons) received by the holder after this date is substituted with the CoCo face value. However, it may not be true if the CoCo is triggered after that date. Secondly, shorter maturity excludes two additional features. The structure of the host instrument of the CoCo remains a coupon bond, without turning into a floating rate bond (as set after the first call date). Then, the callable feature of the CoCo is removed. In particular, the latter is the consequence implied also by the choice of a constant risk-free rate.³² Reasonably, all of these assumptions can cause the upwards shift of the model-price curve, overestimating the CoCo.

Table 5.5: AT1 - S^* Implied by the Equity Derivative Model using the Black-Scholes Assumptions or the Bates Model

	Market Price (% of N)	Implied Barrier S^* (Gbp)	
		Bates-ED	BS-ED
1	99.42	-	106.16
2	104.22	-	-
3	105.25	-	92.91

Additionally, the values of the calibrated parameters and the level M of the simulations

³²Spiegeleer and Schoutens (2014a) extend the Credit Derivative model to the extension risk for the case of a finite-maturity CoCo, considering the new interest rate as a continuous risk-free rate, r_t plus a spread, cs_t .

5. Case Study: Barclays CoCos

Figure 5.6: AT1 (Respectively No.1, No.2, No.3 CoCos) - Comparison between (Monte-Carlo) Bates-ED, BS-ED and Market Prices

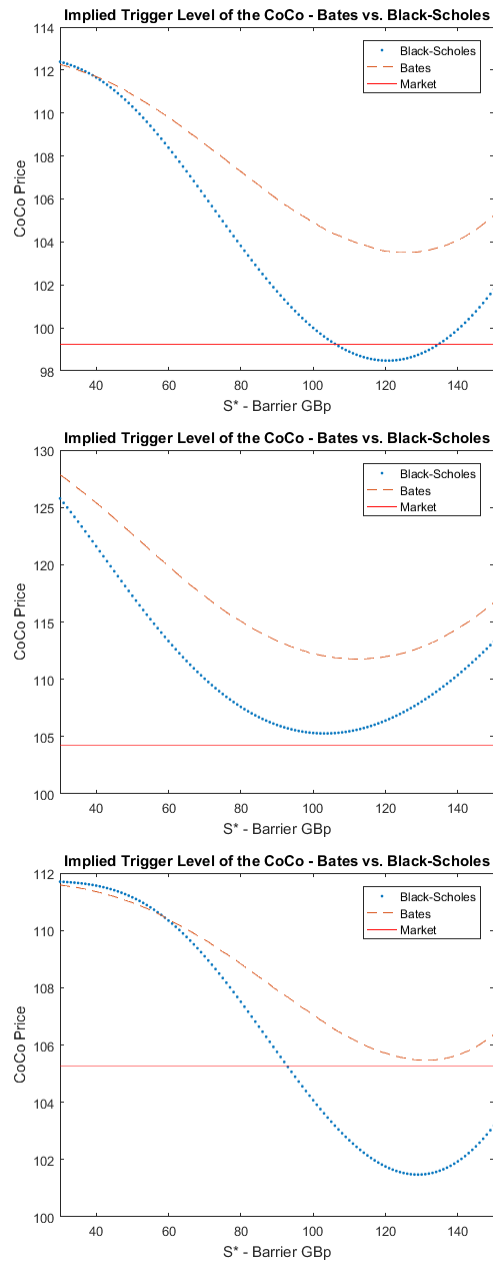

5. Case Study: Barclays CoCos

should also be considered. For this reason, the minimum prices of the Bates-ED model curves are evaluated with the 95% confidence intervals, in order to test if the market prices are included at least in these range of model prices. Table 5.6 clearly rejects this possibility. Indeed, all the three cases show not only a different S_{Min}^* , but also a consistent distance to the market prices.

Table 5.6: AT1 - Evaluation of the Minimum Price in the Bates-ED Model with the 95% Confidence Interval

	S_{Min}^*	Market Price	Min Model Price	95% CI
1	124	99.24	103.51	(103.44;103.57)
2	112	104.22	111.77	(111.86;111.67)
3	131	105.25	105.47	(105.41;105.52)

Focusing on Figure 5.6, the trends of the model prices can be analyzed. The two model formulations produce similar trends. The convexity of the curves is explained in terms of how the components of the CoCo behave. Basically, without conversion into shares, the price of the CoCo bond corresponds to the price of the coupon bond. From that value, the impact of the barrier options let the price decrease. Indeed, an increasing in S^* is correlated to a higher conversion probability, being this value closer to the stock price at the time of the valuation. When the barrier level increases, the short BDI options are more likely to hit their barrier levels. Hence, more future coupon payments are lost by the holder, together with the face value of the CoCo. The price is driven by both the fact that with the triggering the holder faces a loss and the fact that the shares, received at conversion, have a value themselves. After a minimum model price, the triggering of the CoCo has a slow-increasing trend, affected by the higher S^* at which the shares are valued. These are the main factors that affect the price, explaining the convexity. As the conversion probability increases together with S^* , the price of the CoCo decreases. Looking at the extreme scenario in which $S^* = 30$ (very low value with respect to S_0), the holder loses N and receives C_r shares, for a total value of $C_r \cdot S^*$, but the conversion is very unlikely. Conversely, in the case of $S^* = 150$ (high value but still lower than S_0) the probability that S_t hits the barrier level increases, but the holder can be (partially) compensated for the value received in terms of shares.

Concerning the difference between the two models, a reasonable explanation can be found in the different behaviours of the stock prices that the models consider. An example of the stock behaviour is given in appendix A.3. Indeed, while the Black-Scholes model assumes a GBM with fixed volatility for the stock-price, the Bates model allows for extreme

5. Case Study: Barclays CoCos

scenarios, i.e. jumps and the negative correlation between the stock price and the volatility. The curve generated by the Bates-ED model is always on the right side of the BS-ED one, suggesting that the CoCo price has a higher market trigger for a given market price. Nonetheless, the market price is never reached in all the cases of the Bates-ED. Additionally, the range of the market trigger is used to compare the trigger probabilities of the models. The positive relations are shown in Figure 5.7, in which the increasing trigger probabilities with respect to the market triggers are represented for the No.1 CoCo.

Figure 5.7: Trigger Probability as Function of the Market Trigger for No.1 CoCos in the Bates-ED Model and the BS-ED Model

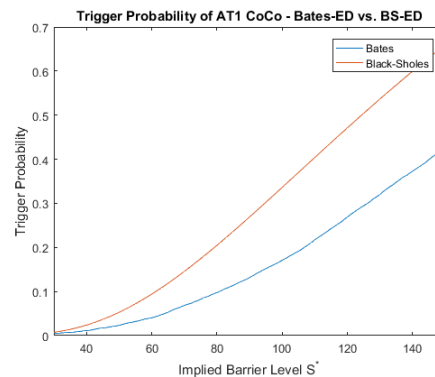

Figure 5.7 can clarify why the market prices are never matched with the model prices. Indeed, as the market trigger increases the conversion probability increases as well, but at a lower rate than the BS-ED case. Thus, the interpretation of these results for the case of AT1 CoCos can drive two hypotheses: the Bates-ED model might have a misleading behaviour or it is not applicable to this category of CoCos. However, these issues are further discussed in the following chapter.

5.3.2 T2 CoCo: Case of a Full Write-Down

The same procedure is here applied to different features of the contingent convertible bonds. Also T2 CoCos are designed with an accounting trigger level of the CET 1 Ratio $\leq 7\%$, for which a full write-down takes place. Recovering the Monte Carlo method to these CoCo bonds, it is possible to highlight the behaviour of the two models. The results of the analysis are summarized below.

Despite the existence of a solution in both the CoCos, neither in this case, the two models provide the same trigger level S^* for CoCos with the same accounting trigger. Looking at the Table 5.7, within each model the discrepancy between the values of S^* is

5. Case Study: Barclays CoCos

Table 5.7: T2 - Trigger Probability and S^* Implied by the Equity Derivative Model using the Black-Scholes Assumptions or the Bates Model

	Market Price (% of N)	Implied Barrier S^* (GBP)		Trigger Probability over the Maturity		
		Bates-ED	BS-ED	Bates-ED	BS-ED	
4	109.08	67	51.95	24.41%	24.85%	over 5.74 years
5	105.10	98	93.67	4.72%	4.75%	over 1.06 years

about 46.27% for the Bates-ED model and about 80.31% for the other one. Consequently, the implied barrier level in the Equity Derivative approach does not depend only on the level of the accounting trigger (which is always the same for all the CoCos), but it must be affected by other factors, e.g. the maturity and the category of CoCo. Again, the trigger probability is lower for the Bates-ED model. In this case, we can observe how the model relates a higher market trigger with a lower probability than the BS-ED model. The discrepancy between the two probabilities increases with the maturities of the CoCos. Indeed, CoCo No.5 has a shorter maturity and the probability of the Bates-ED model is closer to the one of the BS-ED model, even if it is still lower. Limited to those cases, it turns out that the Bates model introduced in the Equity Derivative framework, does not account for additional sources of risks, since even if the S^* is higher, it is related to a lower trigger probability.

Looking at the model-price curves, Figure 5.8 shows how the CoCo prices behave. The trends are different with respect to the previous category.

Figure 5.8: T2 CoCo No.4 and No.5 - Comparison between (Monte-Carlo) Bates-ED, BS-ED and Market Prices

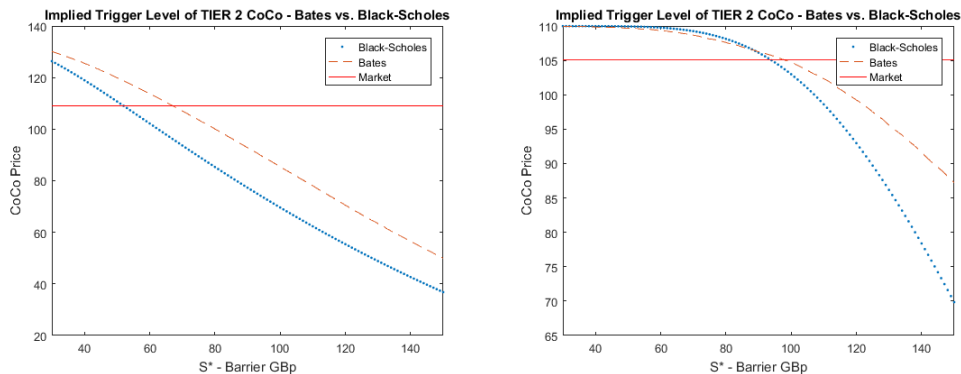

While in the AT1 CoCo case a solution in terms of S^* does not exist, for T2 CoCos

5. Case Study: Barclays CoCos

the two models produce a decreasing curve for the CoCo price as the market trigger level increases. Indeed, the structure of T2 CoCos is designed to cancel the nominal value as well as the future coupon payments at the trigger moment. In this framework, there is not any (partial) gain for the holder. The trend of the two curves is again similar for each CoCo, even though there exists a right shift for the Bates-ED model. The higher level of S^* is closer to the current stock price than in the BS-ED case. As it can be observed in Figure 5.8, there is a different concavity of the model curves. For No.5 CoCo, there is a slight change of the curve when the maturity is set equal to the first call date (Figure 5.8). An explanation can be found in the shorter maturity. Hence, the more-concave curves with respect to the trends of No.4 CoCo (almost strictly decreasing) cause the higher level of implied market trigger level. Therefore, the analysis is repeated for the No.5 CoCo with its real maturity, keeping fixed the coupon rate after the first call date. The results are summarized below (referring to No.5a CoCo).

Table 5.8: No.5a TIER 2 CoCo (No.5 CoCo with the Real Maturity)

	Price	Cpn %	Maturity, T	
5a	105.10	7.75	10/04/2023	6.13 years

Trigger Probability and S^* in the Bates-ED and BS-ED Models

	Market Price (% of N)	Implied Barrier S^* (GBP)		Trigger Probability	
		Bates-ED	BS-ED	Bates-ED	BS-ED
5a	105.10	74	57.43	31.18%	31.48%

Figure 5.9: No.5a TIER 2 CoCo - Comparison between (Monte-Carlo) Bates-ED, BS-ED and Market Prices

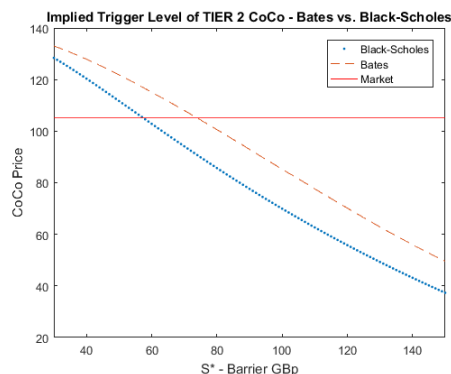

Extending the maturity of the CoCo, it is observed how the model curves become almost

5. Case Study: Barclays CoCos

strictly decreasing as the case of No.4 CoCo bond and the level of the implied trigger decreases. Comparing No.4 and No.5a CoCos, the levels of the trigger are more consistent. It turns out that there is indeed a relation between the market trigger and the maturity and reasonably, comparing CoCos with the same maturity, the levels of S^* is expected to become closer for a fixed accounting trigger.

5.4 Discussion of the Results

If the analysis had been limited to T2 CoCo only, the conclusion would have been that the Bates-ED model leads to a higher level of S^* . Indeed considering the jumps and the variation of the skew of the volatility surface of the CoCos, there is a greater impact of the stock price variations on the CoCo prices. Nonetheless evaluating the trigger probability related to the resulting S^* , it is observed how the Bates-ED model provides a lower trigger probability. Therefore, the only information about the implied market trigger is not sufficient to conclude that the Bates-ED model accounts for additional sources of risks than the BS-ED model. To some extent, this might be due to the formulation of the Equity Derivative framework, being a too stylized version of the reality. Indeed, the use of simplifications of the CoCo features might bring some issues to the analysis even for this category of CoCo bonds, which are less structured than AT1 category. One of the main driver is believed to be the maturity used to assess the payoff of the implicit barrier options (components B and C). Thus, the initial assumptions to simplify the structure of the CoCo should be evaluated in a first stage of the analysis, in order to understand which are the factors that affect the results the most. As in the example of the No.5 CoCo, it should be evaluated whether to include or not the variable structure of the coupon rate; whether to keep the real maturity or to use the first call date. In this analysis, where the risk-free rate is kept constant as well as the dividend yield, dropping also the variation of the coupon rates is believed to be more reasonable than decreasing the maturity to the first call date. Indeed, the latter assumption has more impact on the results, increasing more the level of S^* .

Despite that, modifying the Equity Derivative approach to other sources of risks is easier for TIER 2 category. The same comparison becomes more complex when the analysis is extended to the AT1 CoCos. In the light of the results, the choice to use the Equity Derivative approach for AT1 CoCos does not appear consistent with their structure. Indeed while this market-implied approach is used for easy applications, there are several components that can not be excluded from the analysis. Furthermore, it is not possible to establish any kind of relation between the results in the two categories. Limited to the

5. Case Study: Barclays CoCos

BS-ED model for which there exists a solution almost in any case, the implied barrier levels seem to be dependent not only to the accounting trigger level, but also to other factors such as the market price, the maturity or the coupon rate.

The initial aim of this thesis is to infer the impact of the SV and jumps of the stock price. However, the kind of results obtained in this chapter leads to the impossibility to draw a clear conclusion for the considered CoCos. On the one hand in the valuation of (T2) CoCo bonds, the Bates-ED model provides a misleading relation between the higher market trigger and the lower trigger probability than the BS-ED model. Thus, it is not possible to state that the extended model provides a riskier valuation of the CoCos, even capturing a more realistic path of the stock price. On the other hand, the observed results for AT1 CoCos introduce some issues that affect the correct implementation of the Equity Derivative framework and the valuation of the extension with the Bates model. Thus, the last chapter addresses a number of factors, that I believe to be the most relevant for this analysis.

6 The Viability of the Bates-ED Model

In the light of the last findings, the discussion leads to the evaluation of a number of factors that might affect the results of the previous chapter, leading to the impossibility to find a market trigger for AT1 CoCos. I highlight three categories of issues. The first one accounts for the assumptions made on the CoCo structure, the second one is about the formulation of the Bates-ED model and the last one refers to the calibration of Bates parameters.

6.1 The Simplified Context

The first concern is about the model formulation. Extending the Equity Derivative approach to the stochastic volatility and the stock jumps, two additional sources of risk are included following the relation between the CoCos and the stock price of the financial institution. However, there are a number of complexities that are still excluded from the model. For instance dropping the extension risk through the assumption of a constant risk-free rate, the callable feature of the CoCo is not inferred. Indeed, it excludes the changes in the interest payments during the CoCo lifetime, that motivates the possibility of the issuer to call back the CoCo. Consequently, the extension risk is expected to negatively affect the model price. Reasonably, the downwards shift of the model-price curve would be more emphasized for AT1 CoCos, for which the curve is convex.

Next, my initial assumption of shorter maturities is made to avoid a complete re-formulation of the model, especially in the case of perpetual CoCo bonds. Decreasing the maturity is believed to impact on the value of S^* , but the effect on AT1 category is difficult to be predicted. Indeed, it would be only one of the factors that might drive to an overestimation of the prices with respect to the market price. The easiest case of T2 CoCos allows to infer the difference in the maturities. The No.5 CoCo is analyzed above and shows a slight change in the concavity of the curve when the maturity is set equal to the first call date. Consequently, the results in terms of the implied market trigger and trigger probability also change, while the negative relation between the model price and the market trigger remains almost the same. Following these results, the effect of a shorter maturity is believed to affect also the AT1 case and it is amplified by additional factors that are features of this category only, e.g. the existence of a conversion into shares.

6. The Viability of the Bates-ED Model

6.2 The Impact of the Jumps

Focusing on the formulation, in case of AT1 CoCos the Bates-ED model values the shares at S^* as expressed by equations 3.2 and 3.4. Hence, they are considered more valuable than the shares in the market (with a price equal to the level of the jump). Thus also in this case and for the AT1 category only, the model curve would be made up by overestimated prices. Even though the model is a simplified version of the reality for the CoCo bonds, the original formulation of the model (BS-ED) provides solutions in terms of S^* almost in all the cases, coming to the conclusion that it is possible to obtain the market price using a market trigger. The feasibility of the Bates-ED model and the correct impact of the jumps can be reinforced by the comparison with a simpler model, which includes the stochastic volatility only. For this reason, I recall the paper of Spiegeleer et al. (2017), in which the Equity Derivative model is extended with the Heston model. The implementation is done on No.4 CoCo (T2 CoCo of Barclays) with the data available on 2013. The procedure is mostly the same I apply in my thesis. Spiegeleer et al. (2017) use the Heston model to analyze the impact of the volatility skew on the CoCo price. The solution is a higher S^* and thus, a higher conversion probability with respect to the Black-Scholes version of the model.

Here, I replicate their analysis for the Heston model with my data at the 24th March 2017 on the same CoCo bond (No.4). Then, I make a comparison with the solutions of Spiegeleer et al. (2017). If the model-price curves are similar and the levels of S^* and the trigger probability are higher in the Heston case, then at least for the case of T2 CoCo the Heston model is an extension of the Equity Derivative approach to better capture the behaviour of the stock price. Consequently, it can be inferred the impact of the jumps in the Bates-ED model, that captures an additional source of risk with respect to the Heston model.

The option dataset is used for the calibration of the Heston model and the parameters are summarized below. The w-RMSE is 0.30 and the parameters take extreme values again.

Table 6.1: Calibration of the Heston Model

κ	η	λ	ρ	σ_0
5.0000	0.1149	1.0719	-0.8193	0.3182

Applying these data to the Monte Carlo simulations³³ of the T2 CoCo price and

³³The trials recover the procedure explained in section 4.2. According to the choice of Spiegeleer et al.

6. The Viability of the Bates-ED Model

repeating the trials for $5 \cdot 10^4$ times, the resulting path of the model price is decreasing. Spiegeleer et al. (2017) obtain the same decreasing trend in their analysis. Indeed, the model-price curves share the same concavity, being almost strictly decreasing as the trigger level increases. The trends are represented on the left side of Figure 6.1, while on the right side it is shown the model prices obtained by Spiegeleer et al. (2017) on a face value of 1000 GBp (namely, the correspondent price is 1052.7 GBp) and for a range of $S^* \in [0; 140]$.

Figure 6.1: T2 CoCo No.4 and No.5 - Comparison between Monte-Carlo (Heston) Equity Derivative, BS-ED and Market Prices

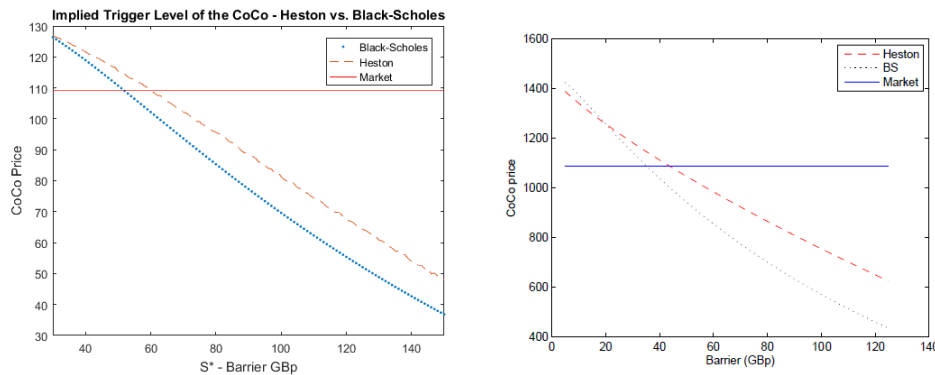

Source: (Right) Spiegeleer et al. (2017)

The comparison is also done in terms of the S^* and the trigger probability, as reported in Table 6.2.

Table 6.2: T2 - Trigger Probability and S^* Implied by the Equity Derivative Model using the Black-Scholes Assumptions and the Heston Model vs. Spiegeleer et al. (2017) Results

	Market Price (% of N)	Implied Barrier S^* (GBp)		Trigger Probability	
		Heston	BS	Heston	BS
My Results	109.08	60	51.95	29.39%	24.85%
Spiegeleer et al. (2017)	105.27	43.49	35.09	35.18%	34.94%

In the comparison the different valuation date must be recalled, such that the same results can not be obtained. However, it is useful to observe that the barrier levels of the models differ as well as the trigger probabilities. The latter ones are higher for the Heston model than the Black-Scholes assumptions. Recalling Table 5.7, the trigger level provided (2017), the QE scheme is replaced by the Milstein scheme, which is explained in appendix A.4.

6. The Viability of the Bates-ED Model

by the Bates-ED model is higher than the one of the Heston model. Therefore, there exists a positive contribution of the stock jumps. However, the trigger probabilities behave differently. The solution of the Heston model is consistent in terms of both the indicators (a higher S^* corresponds to a higher trigger probability), while this is not true for the Bates-ED case.

Given the similarity of the results, as Spiegeleer et al. (2017) conclude that the use of the Heston extension of the Equity Derivative model is suitable for the T2 CoCos of Barclays, the same consideration can be done with my results of the Heston model applied to the T2 CoCo. Conversely, looking at the results obtained in section 5.3.2 for the Bates-ED model, the jump component seems to wrongly affect the trigger probability. Thus, I believe that the Bates-ED is not suitable as an extension to the Equity Derivative model. Indeed, allowing for a wider variation of the stock prices, the model does not reproduce the variation of the real CoCo trigger.

Despite the results, the point remains the impossibility to find a solution in the extended model for the AT1 class of Barclays CoCos. In the light of the higher number of assumptions on their structure, a market-implied model might not be appropriate. Hence, the same application of the Heston model can infer if removing the jump components, the Equity Derivative approach with a stochastic volatility can match the model and the market prices. The hypothesis of the over-valuation of the shares in the Bates-ED model, as in equations 3.2 and 3.4, is removed by the use of the Heston extension, in which the stock price is still a GBM. The correct valuation of the conversion stock is at S^* , as the model assumes. Taking as example No.1 CoCo and the parameters in Table 6.1, the results of the Monte Carlo simulations for the Heston Equity Derivative model are shown below.

Figure 6.2: AT1 CoCo No.1 - Comparison between Monte-Carlo (Heston) Equity Derivative, BS-ED and Market Prices

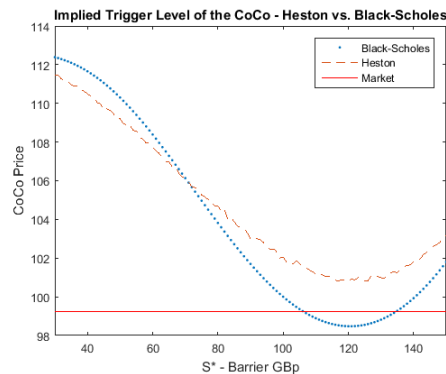

6. The Viability of the Bates-ED Model

Table 6.3: AT1 - S^* Implied by the Equity Derivative Model using the Black-Scholes Assumptions or the Heston Model

	Market Price (% of N)	Implied Barrier S^* (GBP)	
		Heston	Black-Scholes
1	99.42	-	106.16

Again, a solution does not exist for the AT1 CoCo, even if the converted shares are correctly priced. The trend is similar to the first picture of Figure 5.6. The Bates model price reaches its minimum after the Heston model price, which is given in Table 6.4, together with its 95% confidence interval and the correspondent S_{Min}^* . As it is observed, the market price is far from being included even in the confidence interval of the minimum of the model-price curve.

Table 6.4: AT1 No.1 CoCo - Evaluation of the Minimum Price in the Heston Equity Derivative Model with the 95% Confidence Interval

	S_{Min}^*	Market Price	Min Model Price	95% CI
1	120	99.24	100.80	(100.66;100.95)

The reasonable interpretation is that the valuation of the conversion shares in case of jumps does not affect so much the results. Instead, the Equity Derivative models are not adaptable to price AT1 CoCos of Barclays, probably because of the formulation of the model that can not capture the complexity of the CoCo structure, deviating from the real prices of the financial instruments. From the above considerations, it is discussed how dropping some of the initial assumptions might bring to different results. Indeed, the level of the CoCo price might decrease more and get closer to the market level. Nevertheless, the implementation of further sources of risk is left outside the purpose of this thesis, in which the Equity Derivative model is analyzed with the only extension of the Bates model.

6.3 The Model Calibration

Disregarding the accuracy of the results (different values of the market trigger) or the validity of the choice to use the Bates-ED model, a last attempt is done in order to understand why the latter does not provide any solution in terms of S^* in the case of AT1 category. Indeed, while the BS-ED model is applicable, there must be some other factors that affect the case of the Bates-ED model, causing the overestimation of the AT1 CoCo

6. The Viability of the Bates-ED Model

prices. The difference between the two formulations of the Equity Derivative model consists of the calibrated parameters of the Bates model. The analysis is based on a calibration that might not be accurate in terms of initial data or in its formulation, optimizing too many parameters. Indeed, using more liquid OTM option data or making some assumptions on a number of parameters might increase the quality of the calibration, finding a solution also for AT1 category of CoCos.

Taking aside the accuracy of the results, the calibrated parameters lead to a solution in case of T2 CoCos. Conversely, given the different loss-absorption mechanism, the calibration might have a greater impact on the model-prices of AT1 CoCos. Assuming the feasibility of the the Bates-ED model in this framework, I use a sensitivity analysis in order to check the role of my parameters on the model-price curve for AT1 CoCos. Indeed, in this framework it is convex and this can amplify the effect of distorted parameters.

The Model Price

Taking as example the case of No.1 CoCo, it can be observed whether the Bates-ED model leads to different results. The analysis is done looking at the impact of the variations of two parameters at time, keeping all the other fixed, as in Table 5.2. Monte Carlo simulations are done with 10^4 trials and 2500 time steps and the model price is evaluated for a range of $S^* \in [10; 150]$. The variations are implemented by looking at the values that seem to be more extreme. Those are summarized in the Tables below and they try to improve the quality of the calibrated parameters. The first set, called *Test 1*, is designed to decrease the value of κ and to increase the value of η , in order to lowering the speed of mean reversion of the stock-variance process to an increasing long-time variance. The second one, *Test 2*, increases the initial value of the volatility process (σ_0) and decreases the size of the jumps in the stock prices.

Table 6.5: **Test 1** - Sets of the Parameters of the Bates Model

κ	η	λ	ρ	σ_0	λ_J	μ_J	σ_J
4.6	0.003	0.1189	-0.4695	0.1819	1.1018	-0.1399	0.2772
3.5	0.2	0.1189	-0.4695	0.1819	1.1018	-0.1399	0.2772
2.5	0.4	0.1189	-0.4695	0.1819	1.1018	-0.1399	0.2772
1.5	0.6	0.1189	-0.4695	0.1819	1.1018	-0.1399	0.2772
0.5	0.8	0.1189	-0.4695	0.1819	1.1018	-0.1399	0.2772

The results are given in Figure 6.3, together with the market price of No.1 CoCo.

6. The Viability of the Bates-ED Model

Table 6.6: **Test 2** - Sets of the Parameters of the Bates Model

κ	η	λ	ρ	σ_0	λ_J	μ_J	σ_J
4.6048	0.0031	0.1189	-0.4695	0.1	1.2	-0.1399	0.2772
4.6048	0.0031	0.1189	-0.4695	0.2	1.0	-0.1399	0.2772
4.6048	0.0031	0.1189	-0.4695	0.4	0.8	-0.1399	0.2772
4.6048	0.0031	0.1189	-0.4695	0.6	0.6	-0.1399	0.2772
4.6048	0.0031	0.1189	-0.4695	0.8	0.4	-0.1399	0.2772

Figure 6.3: No.1 CoCo Market Price vs. (Left) **Test 1** Bates-ED Model Price; (Right) **Test 2** Bates-ED Model Price

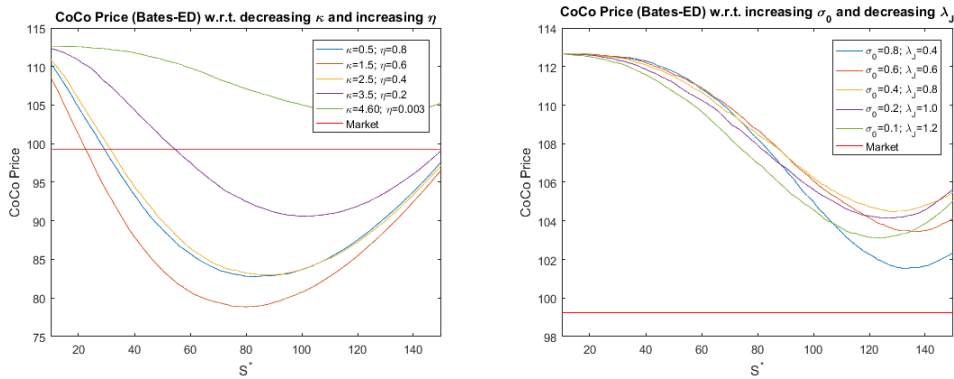

Starting with the analysis of the Test 1, the variations of κ and η allows the model price to decrease and match with the market price, in almost all the cases. The original price curve of the Bates-ED model, obtained in the previous chapter, is much higher than all the others. Indeed, the more the parameters change from the initial case of this thesis, the more convex the trend is. Despite the concerns about the accuracy of those values of S^* and the correspondent trigger probability, the Bates-ED model is believed to be applicable to AT1 CoCos, following the similar results of the BS-ED.

Evaluating now the Test 2, it is observed that again the model does not lead to any solution in terms of the implied barrier level. In this case, the test still highlights a decreasing trend, but it is not as effective as the previous case. Indeed, using the original parameters, the price curve does not take an extreme behaviour with respect to the other curves, probably being still altered by the values of κ and η .

6. The Viability of the Bates-ED Model

The volatility Skew

Furthermore, the parameters affects the volatility skew. Hence, the 2 tests are applied to different values of S^* , $S^* = 30, 78, 150$. The IVs are calculated recovering the example made for the European call options in section 3.2.2 under *Parameter Analysis*. This time, the volatility skew is plotted with respect to different maturities, assuming a strike price K equal to the barrier level S^* of the CoCo and an underlying price equal to S_0 . The data are summarized in the Table below, while the Bates parameters are recalled from Tables 6.5 and 6.6.

Table 6.7: Data for the Implied Volatility of European Call Options

S_0	K	T
226.65	[30, 78, 150]	[0;3]

The first two cases of S^* reflect mainly a non-stress situation, namely the barrier level is far from the current stock price ($S^* \ll S_0$). In the last case, the difference between S^* and the current stock price decreases. Rationally, if the current stock price decreases up to the barrier level, the behaviour of the CoCo price changes according to the higher probability to be triggered. Thus, this kind of variations reflect the changes in the volatility skew of the implicit options in the CoCo, as formulated in the Equity Derivative model.³⁴

The shape of the volatility skew is given in the pictures of Figure 6.4, for the two tests.

The left asymmetry and the shape of a smile of the volatility skew appear almost constant, meaning that the IV increases as the maturity decreases. Assuming that the parameters of the Bates model change, the impact of the volatility skew on the price of the CoCo is different. The variation is dependent not only on the parameters, but also on the value of the barrier level, which in this case is the strike of the call option. Indeed, an increasing strike price means that these call options are less in-the-money. An opposite argument can be done for put options, in which an increasing strike price, closer to the stock price, increases their moneyness.

In this case, if the volatility increases, the option is more likely to hit the barrier, triggering the CoCo. Hence, its price is expected to slowly increase, due to the fact that the holder faces the conversion into shares (the loss of the nominal value and future coupon payments is partially replaced by the revenues from the value of the shares).

For what concerns the original parameters of the analysis, as in Table 5.2, the described variation with respect to the values of S^* is not observed, coming to the conclusion that

³⁴An example can be found in Spiegeleer et al. (2017) for the Heston model.

6. The Viability of the Bates-ED Model

Figure 6.4: Volatility Skew for European Call Options w.r.t. $S^* \in [30, 78, 150]$ - (Left) **Test 1**; (Right) **Test 2**

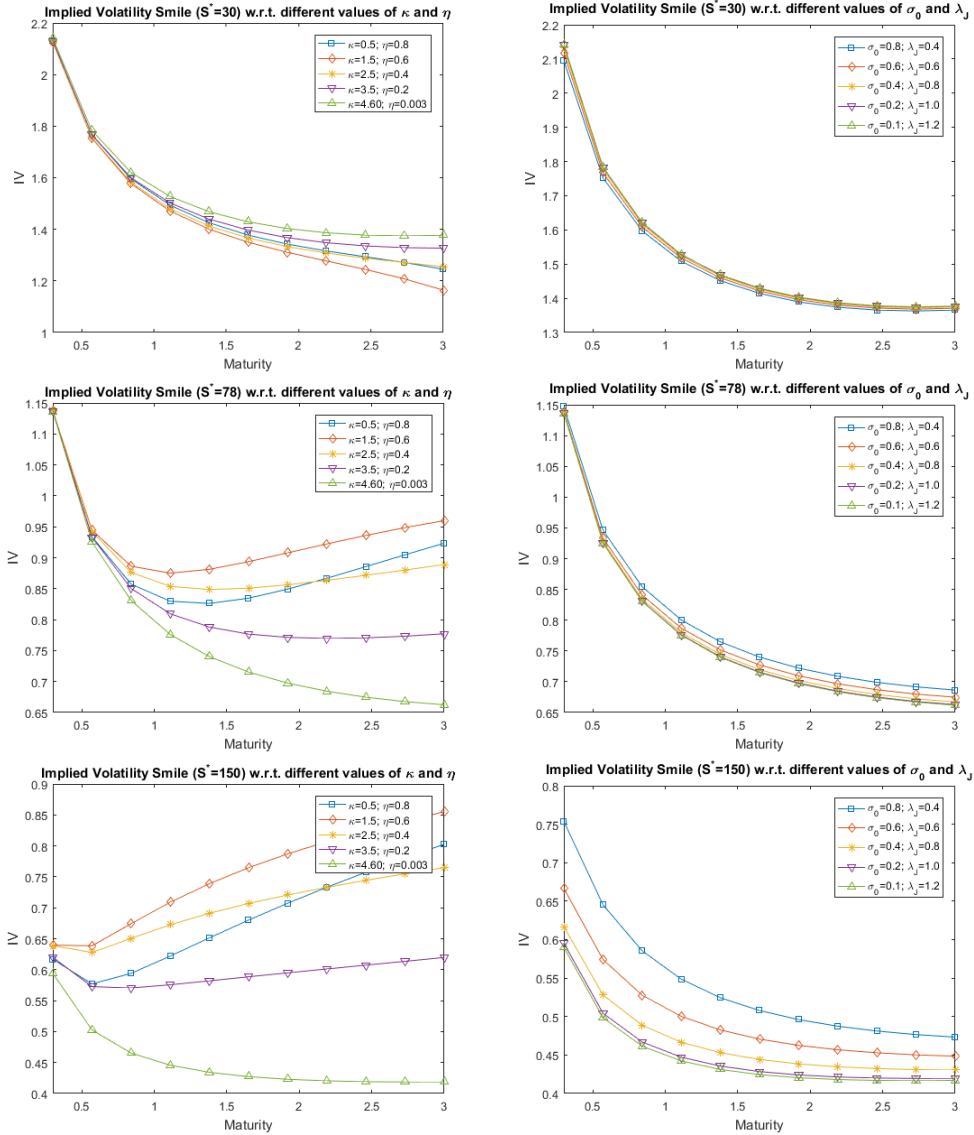

6. The Viability of the Bates-ED Model

those values alter the processes of both the stock volatility and the stock price. Indeed, the stock variance process generated by the calibration of the Bates model is *stable*, in the sense that the high speed brings a fast convergence of the process around its mean reverting level that, in this case, is very low.

6.3.1 Different Approaches

In light of the last findings, for which the calibrated Bates parameters affect too much the results, it is believed that also the Heston case applied to the AT1 CoCos would give a result in terms of S^* if those values were changed. This conclusion can be argued also looking at the Test 1, in which variations in the CIR process parameters are made. Additionally, due to the structure of the Heston and the Bates models, it is expected that the resulting barrier level for the former is lower than the one obtained for the Bates-ED model and vice versa for the trigger probabilities. Indeed using this kind of extension, only a much higher implied market trigger would also provide a higher trigger probability than the BS-ED model as well as the Heston one. However, it is believed that the only variation of few parameters, keeping fixed the others, it is not sufficient to state that the Bates-ED model would change that much the level of the trigger probability. One way to prove it would be obtaining more accurate parameters that reflect a real calibration. In order to get back them, a number of variations of the calibrated procedure can be suggested, but their implementation is left to future research.

First of all, the quality of data used for the optimization problem can be improved, choosing more liquid price of the option dataset. Additionally, the options might be collected among American options, in order to calibrate the model for the specific case of AT1 CoCos. If those kind of data are not available, the implied volatilities can be used to look for the option prices under the Black-Scholes model (closed-form expression).

Regarding the number of parameters, it can be lowered, fixing some of them to reasonable values and setting some constraints in the optimization problem. Some example are provided below:

- The initial value of the variance can be set equal to the Black-Scholes volatility (estimated from the historical market prices of the stock);
- The size of the jumps can have a lower bound equal to the default intensity of the CDS;
- The speed of mean reversion can be constrained not to take high values;

6. The Viability of the Bates-ED Model

The last concern is about the optimization problem. Indeed, it can be replaced by the minimization against the implied volatilities observed in the market or the use of a different algorithm than the Nelder-Mead.

6.4 Final Remarks

The implementation of some of these suggestions would lead to different parameters that are believed to affect the overestimation of the model prices especially for AT1 CoCos. However, as it is explained above, this is only one of the factors that should be taken into account pricing these financial instruments. Clearly, the application of the analysis to different categories of regulatory capital helps to understand the probable misleading behaviour of the model, when some assumptions are made, e.g. the shorter maturity of No.5 CoCo. In this thesis it is proved that if the stock price does not follow the Black-Scholes assumptions, it is required more accuracy to model the features of the CoCos as well as the model parameters.³⁵ However, considering the Heston model, it introduces the stochastic volatility to the stock prices, that still behave as a GBM. Even if the calibration is not so accurate affecting the model applicability in the case of AT1 CoCos, the fact that the stock prices are still a GBM is consistent with the formulation of market-implied approach. Conversely, the case of the Bates-ED model does not provide the same solution. Namely, a higher implied market trigger is not related to a higher trigger probability. A reasonable explanation can be found in the difference between the market trigger and the accounting trigger, that increases. Looking at the assumptions of the Equity Derivative approach and recalling Figure 3.1, it can be observed how the behaviour of the CET 1 Ratio is similar to the GBM of the stock prices. Indeed, in pricing the CoCo, the existence of the PONV is not considered. Thus without the Regulatory trigger, as the Equity Derivative framework assumes, the Black-Scholes and the Heston assumptions for the stock price are more in line with the model approach. Vice versa, including the additional trigger, there exists the discretion of the regulator to trigger the CoCo even for higher level of the accounting trigger than the one set in the prospectus. Therefore, the CET 1 Ratio is more likely to have jumps and it can motivates their introduction also in the stock prices. To some extent, this is considered to affect the model applicability, being the reason why the formulation of this thesis (with the extension of the Bates model) provides a misleading interpretation of the results. My suggestion is to use different kind of models

³⁵For instance, the first call date equal to the maturity of perpetual AT1 CoCos is used also by Spiegeleer et al. (2014), addressing the differences in S^* between Additional TIER 1 and TIER 2 CoCos in the original formulation of the Equity Derivative model.

6. The Viability of the Bates-ED Model

if we want to capture more market-conform behaviour of the stock price. For instance, the hybrid models outlined in the literature review might perform better, considering a proper impact of the jumps in both the stock and the accounting trigger paths. The consequence is that for the CoCo pricing with a less stylized version of the reality, a more complex model formulation is required, as these models that are classified in between the implied-market and the structural approaches.

7 Conclusions

I base my thesis on the Equity Derivative model of Spiegeleer et al. (2017) for Barclays' CoCos and implement it with the extension of the Bates model in place of the Black-Scholes assumptions of the stock prices distributed as a GBM and a constant stock volatility. Using two categories of CoCos, I find that the Bates-ED model accounts for a more market-conform behaviour of the stock prices. Indeed, it takes into account the jump component on the shape of the volatility skew, which affects the changes in price of the CoCo. However, when the stock prices are not a GBM, the market trigger does not reflect the trend of the accounting trigger, such that the model relates a higher barrier level to a lower trigger probability with respect to the Black-Scholes case. Hence, the introduction of the jumps is considered not consistent with this market-implied approach that connects the behaviour of the CET 1 Ratio with the stock price.

Moreover, a drawback of the general formulation of the Equity Derivative model is that for fixed level of accounting trigger, the model is unable to lead to the same implied market trigger, which is believed to be affected by the CoCo maturity also.

Regarding the viability of the model with the Bates extension, the simplification of the CoCo features and the calibration of the parameters are considered the most effective factors. Firstly, it is shown how the model should be adapted to the real maturity. The suggestion is to modify the formulation of the model, even giving up its simplicity. Secondly, the use of the Bates model is compared to the Heston model, in order to infer the impact of the jumps, valuing the conversion shares at S^* . It shows how the jumps increase S^* for T2 CoCos, while the trigger probability of the Heston model is higher than the BS-ED case. Instead, neither the case of the Heston model is adaptable to AT1 CoCos as formulated in this thesis. Finally, the use OTM options affects the accuracy of the model itself. In particular, the existence of 7 parameters and one state variable leads to an increasing sensitivity to the initial data. Indeed, the model can not correctly evaluate the case of AT1 CoCos probably because of the high number of calibrated parameters and the illiquid prices of OTM plain-vanilla options. This is confirmed by the sensitivity of the model price and of the volatility skew to simultaneous variations of some parameters. Thus, it is suggested the use of other initial data to calibrate the model, overcoming the problem of illiquid instruments, and the reduction of the number of the parameters in the optimization problem, assuming them exogenous.

A Appendix

A.1 CDS: Bootstrapping the Default Intensities

In a CDS contract, the CDS spread is the premium such that the discounted cash flows of the *default leg* paid by the protection seller and the *premium leg* paid by the protection buyer are equal. Thus, the CDS spread is defined as (Herbertsson, 2016)

$$\begin{aligned} cs &= \frac{\text{premium leg}}{\text{default leg}} \\ &= \frac{(1 - \pi) \sum_{i=1}^{4T} e^{-rt_i} (F(t_i) - F(t_{i-1}))}{\sum_{i=1}^{4T} e^{-rt_i} (1 - F(t_i)) \frac{1}{4}}, \end{aligned} \quad (\text{A.1})$$

in which $F(t) = \mathbb{P}[t^* \leq t]$, r is the constant risk-free rate, π is the constant recovery rate, $t_i = \frac{i}{4}$ expresses the quarterly coupon payments up to the maturity T . This formulation does not consider the accrued premium. In addition, it is made the assumptions of a deterministic (piecewise constant) default intensity $\lambda(t)$. Therefore, the default intensity is defined according to the law:

$$\lambda(t) = \begin{cases} \lambda_1, & \text{if } 0 \leq t < \tilde{T}_1 \\ \lambda_2, & \text{if } \tilde{T}_1 \leq t < \tilde{T}_2 \\ \vdots & \\ \lambda_{10}, & \text{if } \tilde{T}_9 \leq t < \tilde{T}_{10} \end{cases}$$

The values of $\lambda(t)$ can be obtained through the calibration with the market data. Namely, the default intensities can be bootstrapped from the market CDS spreads using the *rule-of-thumb*

$$cs_M(\tilde{T}) = (1 - \pi) \cdot \lambda(\tilde{T}). \quad (\text{A.2})$$

Once $\lambda(t)$ is defined, it can be used to calculate the default probability, that for the case of a piecewise default intensity is equal to

$$F(t) = \begin{cases} 1 - e^{-\lambda_1 t}, & \text{if } 0 \leq t < \tilde{T}_1 \\ 1 - e^{-\lambda_1 \tilde{T}_1 - \lambda_2 (t - \tilde{T}_1)}, & \text{if } \tilde{T}_1 \leq t < \tilde{T}_2 \\ \vdots & \\ 1 - e^{-\sum_{j=1}^9 \lambda_j (\tilde{T}_j - \tilde{T}_{j-1}) - \lambda_{10} (t - \tilde{T}_9)}, & \text{if } \tilde{T}_9 \leq t < \tilde{T}_{10} \end{cases}$$

A.2 Other Results of the Calibrated Bates Model

Figure A.1 shows 3 optimization trials made for the calibration of the Bates model, using the mid prices of the option dataset (including all the 164 plain-vanilla options). The α -vectors are reported below, together with the correspondent w-RMSE.

Table A.1: Trials for the Calibration w.r.t α

	α -vector [Call; Put; Binary Put]	w-RMSE
1	[0.5; -1.5; -0.5]	0.6174
2	[0.4; -1.65; -0.5]	0.5382
3	[0.35; -1.75; -0.5]	0.5437

Figure A.1 shows how changing the values of the α -vector the w-RMSE is affected, lowering the accuracy of the resulting parameters.

However, the main issue is caused by the option mid prices. Indeed, Table A.2 summarizes respectively the parameters obtained for the three trials outlined above.

Table A.2: Calibration of the Bates Model - Resulting Parameters

	κ	η	λ	ρ	σ_0	λ_J	μ_J	σ_J
1	4.9998	0.0129	0.3593	-1.0000	0.2557	0.5581	-0.1880	0.4010
2	4.9998	0.0153	0.3906	-1.0000	0.2364	0.5977	-0.1691	0.3730
3	5.0000	0.0156	0.3955	-1.0000	0.2243	0.6127	-0.1725	0.3735

It is observed that using this kind of data, ρ and κ are pushed respectively to the lower bound and to an extremely high value. Therefore, the overall result is not taken into account due to the "unreasonable" values of those parameters, which are unlikely faced on the market. Here, the explanation is given in terms of the option dataset. Indeed, the OTM options used in the analysis are not enough traded in the market, thus they can hide outlier prices and affect the calibration results. In the light of those tests, it is preferred to continue the analysis with the screening data and the (slightly) more accurate parameters, even if the obtained calibration w-RMSE is high.

Figure A.1: Calibration of the Bates model w.r.t. α

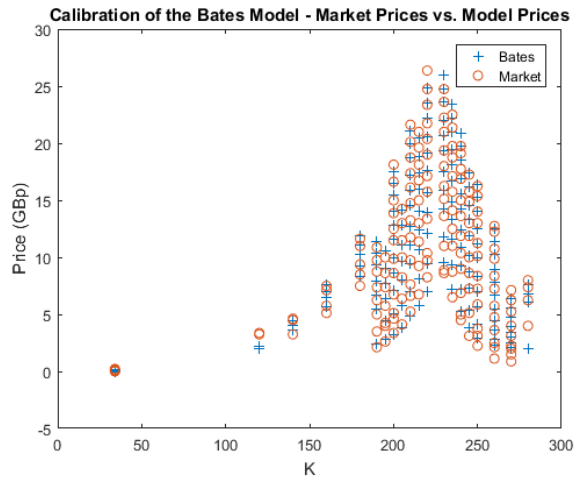
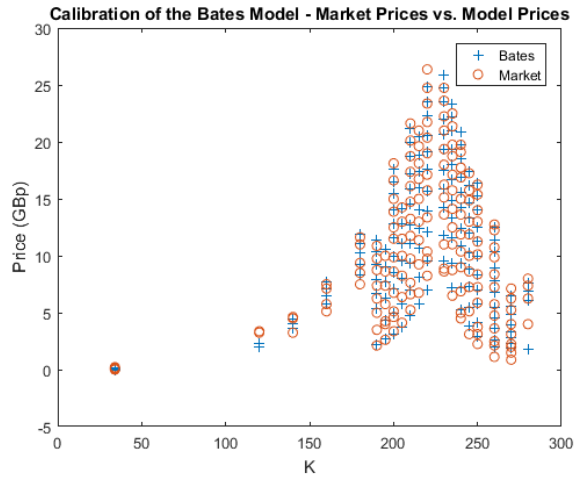
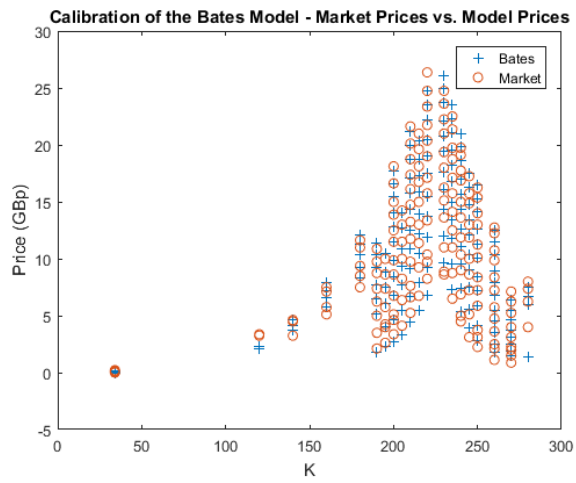

A.3 Stock and Volatility Behaviours

During the analysis of this thesis, it is stated how the Bates model differs from the Black-Scholes assumptions for the behaviour of the stock price and its volatility. Here a graphical representation is provided.

First of all, the path of the GBM of the stock prices is represented in Figure A.2. The simulations, respectively of one and 10^4 trials, are made over a period of 10 years and 2500 time-steps.³⁶ The variation of the stock price is moderate and it increases with the time.

Figure A.2: GBM Application - Simulated Path of the Stock Price over 10 years divided into 2500 Time-Steps for one and 10^4 trials

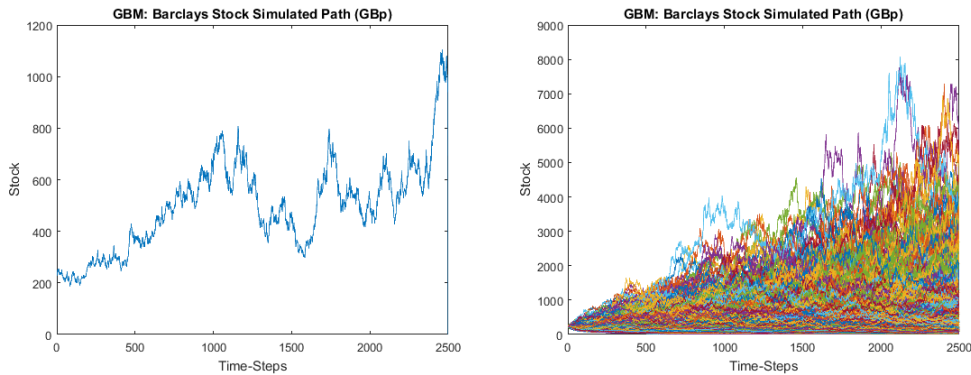

Conversely, the implementation of the Quadratic Scheme in the Bates Model and the use of Monte Carlo simulations is shown by Figures A.3 and A.4, in which the path of the simulated stock price and the SV for one and 10^4 trials are represented. The applications are made using the same 10-year period, discretized into 2500 time-steps.

³⁶For this kind of example the Euler scheme is implemented.

A. Appendix

Figure A.3: QE Application - One Simulated Path of the Stock Price and its Volatility over 10 years divided into 2500 Time-Steps

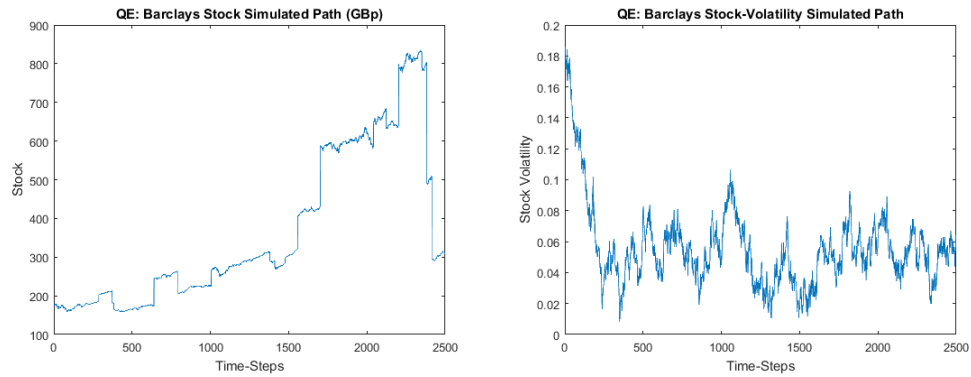
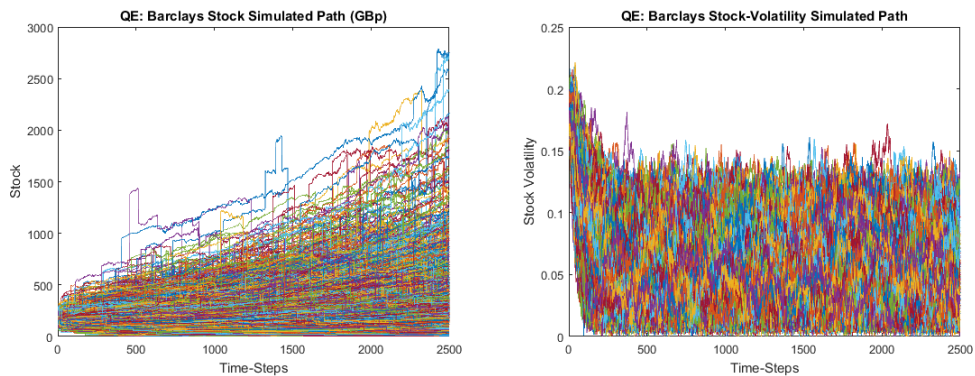

Figure A.4: QE Application - 10^4 Simulated Paths of the Stock Price and its Volatility over 10 years divided into 2500 Time-Steps



A.4 The Milstein Scheme for the Heston Model

In order to work out the Monte Carlo algorithm in section ??, the processes 3.7 is discretized using the Milstein scheme, following the same approach used by Spiegeleer et al. (2017). It achieves a higher level of accuracy than the Euler scheme, which converges slowly to the true value, as it is stated in section 4.2.1.

In this case, the stock-price process is rewritten applying the Itô's Lemma such that, said $dx_t = d \log(S_t)$, it becomes

$$dx_t = \left(r - q - \frac{v_t}{2} \right) dt + \sqrt{v_t} dW_t^{(1)}.$$

Consequently, the result of the Milstein discretization (for any iteration i) follows

$$\begin{aligned} x_{i,t+\Delta} &= x_{i,t} + \left(r - q - \frac{v_{i,t}^+}{2} \right) \Delta + \sqrt{v_{i,t}^+} \Delta W^{(1)} \\ v_{i,t+\Delta} &= v_{i,t} + \kappa(\eta - v_{i,t}^+) \Delta + \lambda \sqrt{v_{i,t}^+} \Delta W^{(2)} + \frac{\lambda^2}{4} \Delta (W^{(2)^2} - 1), \end{aligned} \tag{A.3}$$

in which $v_{i,t}^+ = \max\{0, v_{i,t}\}$ and $\Delta = T/m$ is the time interval. In addition, the two correlated Wiener processes are generated through two random variables with a normal distribution, $Z_{i,1}, Z_{i,2} \sim N(0, 1)$ such that

$$\begin{aligned} W_i^{(1)} &= Z_{i,1} \\ W_i^{(2)} &= \rho Z_{i,1} + \sqrt{1 - \rho^2} Z_{i,2}. \end{aligned} \tag{A.4}$$

References

- Albul, B., Jaffee, D. M., and Tchisty, A. (2010). Contingent Convertible Bonds and Capital Structure Decisions. *Working paper*. University of California at Berkeley, Haas School of Business.
- Andersen, L. B. (2007). Simple and efficient simulation of the Heston stochastic volatility model. *Journal of Computational Finance*. 11.3, pp. 1–42.
- Avdjiev, S., Bolton, P., Kartasheva, A., Jiang, W., and Bogdanova, B. (2015). CoCo Bond Issuance and Bank Funding Costs. *Bank for International Settlements (BIS) in collaboration with Columbia University*, pp. 1–57.
- Avdjiev, S., Kartasheva, A., and Bogdanova, B. (2013). Coco's: A Primer. *Bank for International Settlements Quarterly Review 2013*, pp. 43–56.
- Bates, D. (1996). Jumps and Stochastic Volatility: Exchange Rate Processes Implicit in Deutsche Mark Options. *The Review of Financial Studies*. 9, pp. 69–107.
- Batten, J. A., Khaw, K. L.-H., and Young, M. R. (2014). Convertible Bond Pricing Models. *Journal of Economic Surveys*. 28, pp. 775–803.
- BIS (2009). Strengthening The Resilience Of The Banking Sector. *Consultative Document*, pp. 1–80.
- BIS (2010b). Proposal To Ensure The Loss Absorbency Of Regulatory Capital At The Point Of Non-Viability. *Consultative Document*, pp. 1–10.
- BIS (2011a). Basel Committee issues final elements of the reforms to raise the quality of regulatory capital. *Consultative Document*, pp. 1–4.
- Black, F. and Scholes, M. (1973). The Pricing of Options and Corporate Liabilities. *Journal of Political Economy*. 81.3, pp. 637–654.
- Broadie, M. and Kaya, O. (2006). Exact Simulation of Stochastic Volatility and Other Affine Jump Diffusion Processes. *Operations Research*. 54, pp. 217–231.
- Carr, P. and Madan, D. B. (1999). Option valuation using the fast Fourier transform. *The Journal of Computational Finance*. 2, pp. 61–73.
- Corcuera, J. M., Spiegeleer, J., Ferreiro-Castilla, A., Kyprianou, A. E., Madan, D. B., and Schoutens, W. (2013). Efficient Pricing of Contingent Convertibles Under Smile Conform Models. *Journal of Credit Risk*. 9.3, pp. 121–140.
- EPRS (2016). *Contingent convertible securities - Is a storm brewing?*

REFERENCES

- Flannery, M. J. (2002). No Pain, No Gain? Effecting Market Discipline Via 'Reverse Convertible Debentures'. *Working paper*, pp. 1–32.
- Flannery, M. J. (2009). Stabilizing Large Financial Institutions with Contingent Capital Certificates. *Working paper*, pp. 1–34.
- Gatheral, J. (2011). *The Volatility Surface: A Practitioner's Guide*. Wiley Finance.
- Gupta, A., Akuzawa, T., and Nishiyama, Y. (2013). Quantitative evaluation of contingent capital and its applications. *The North American Journal of Economics and Finance*. 26, pp. 457–486.
- Herbertsson, A. (2016). *Credit Risk Modelling - Lecture Notes*. University of Gothenburg.
- Heston, S. L. (1993). A Closed-Form Solution for Options with Stochastic Volatility with Applications to Bond and Currency Options. *The Review of Financial Studies*. 6, pp. 327–343.
- Hibbert, A. M., Daigler, R. T., and Dupoyet, B. (2008). A behavioral explanation for the negative asymmetric return–volatility relation. *Journal of Banking and Finance*. 32, pp. 2254–2266.
- Hilsher, J. and Raviv, A. (2014). Bank Stability and Market Discipline: The Effect of Contingent Capital on Risk Taking and Default Probability. *Journal of Corporate Finance*. 53, pp. 1–45.
- Hull, J. C. (2014). *Options, Futures, and Other Derivatives, 9th Edition*. Pearson (University of Toronto).
- Jung, H. Y. (2012). “Pricing of Contingent Convertibles.” MA thesis. University of Pennsylvania.
- Kienitz, I. and Wetterau, D. (2012). *Financial Modelling. Theory, Implementation and Practice with MATLAB Source*. Wiley Finance.
- Køll, J. (2014). “Pricing of Contingent Convertibles in an equity derivatives framework.” MA thesis. Aarhus University.
- Kwok, Y. K., Leung, K. S., and Wong, H. Y. (2012). Efficient Options Pricing Using the Fast Fourier Transform. *Handbook of Computational Finance*. 4, pp. 579–604.
- Lee, R. W. (2004). Option Pricing by Transform Methods: Extensions, Unification, and Error Control. *The Journal of Computational Finance*. 7, pp. 51–86.
- Merton, R. C. (1976). Option Pricing When Underlying Stock Returns are Discontinuous. *Journal of Financial Economics*. 3.1-2, pp. 125–144.
- Moodley, N. (2005). “The Heston Model: A Practical Approach with Matlab Code.” MA thesis. University of the Witwatersrand.

REFERENCES

- Rubinstein, M. and Reiner, E. (1991). Unscrambling the Binary Code. *Risk Magazine*. 4, pp. 75–83.
- Spiegeleer, J., Schoutens, W., and Hulle, C. V. (2014). *The Handbook of Hybrid Securities: Convertible Bonds, CoCo Bonds and Bail-In*. Wiley (Wiley finance series).
- Spiegeleer, J., Forsys, M. B., Marquet, I., and Schoutens, W. (2017). The impact of skew on the pricing of CoCo bonds. *International Journal of Financial Engineering*. 11.3, pp. 1–19.
- Spiegeleer, J., Marquet, I., and Schoutens, W. (2015). CoCo Bonds and Implied CET1 Volatility. *SSRN report*, pp. 1–27.
- Spiegeleer, J. and Schoutens, W. (2012a). Pricing Contingent Convertibles: A Derivatives Approach. *Journal of Derivatives*. 20.2, pp. 27–36.
- Spiegeleer, J. and Schoutens, W. (2012b). Steering a Bank Around a Death Spiral: Multiple Trigger CoCos. *Wilmott*. 2012.59, pp. 62–69.
- Spiegeleer, J. and Schoutens, W. (2014a). CoCo Bonds with Extension Risk. *SSRN Report*, pp. 1–33.
- Teneberg, H. (2012). Pricing Contingent Convertibles using an Equity Derivatives Jump Diffusion Approach. *Student paper*. KTH.
- Wilkens, S. and Bethke, N. (2014). Contingent Convertible ('CoCo') Bonds: A First Empirical Assessment of Selected Pricing Models. *Financial Analysts Journal*. 70.2, pp. 59–77.