

# Regulators of Membrane Fluidity

Kiran Busayavalasa



UNIVERSITY OF GOTHENBURG

Department of Chemistry and Molecular Biology  
Gothenburg, Sweden  
2020

Regulators of Membrane Fluidity  
©Kiran Busayavalasa 2020

ISBN 978-91-7833-920-4 (PDF)  
ISBN 978-91-7833-921-1 (Print)

Printed by STEMA SPECIALTRYCK AB, Gothenburg, Sweden, 2020

*Dedicated to my family*



# Abstract

*Caenorhabditis elegans* PAQR-2 (a homolog of the mammalian AdipoR1 and AdipoR2 proteins) and IGLR-2 (homolog of the mammalian LRIG proteins) form a complex at the plasma membrane that regulates fatty acid desaturation to protect against saturated fatty acid-induced membrane rigidification. Maintenance of membrane homeostasis is fundamental for most cellular processes and, given its importance, robust regulatory mechanisms must exist that adjust lipid composition to compensate for dietary variation. To better understand this phenomenon, we performed forward genetic screens in *C. elegans* and isolated mutants that improve tolerance to dietary saturated fatty acids. These include eight new loss of function alleles of the novel gene *fld-1*, one loss of function allele of *acs-13* and one gain of function allele of *paqr-1*. *fld-1* encodes a homolog of the human TLCDC1/2 transmembrane proteins. The FLD-1 protein is localized on plasma membranes and mutations in the *fld-1* gene help to suppress the phenotypes of *paqr-2* mutant worms, including its characteristic membrane fluidity defects. The wild-type *C. elegans* FLD-1 and human TLCDC1/2 proteins do not regulate the synthesis of long-chain polyunsaturated fatty acids but rather limit their incorporation into phospholipids.

*C. elegans acs-13* encodes a homolog of the human acyl-CoA synthetase ACSL1. The ACS-13 protein is localized to mitochondrial membranes where it likely activates and channels long chain fatty acids for import. In human cells, ACSL1 activity potentiates lipotoxicity by the saturated fatty acid palmitate (16:0) because it depletes the cells of membrane-fluidizing unsaturated fatty acids. Echoing our findings in *C. elegans*, knockdown of ACSL1 in human cells using siRNA also protects against the membrane-rigidifying effects of palmitate and acts as a suppressor of AdipoR2 knockdown.

A novel gain-of-function allele of PAQR-1, a paralog of PAQR-2, takes over the role of PAQR-2 for downstream effectors. Through genetic interaction studies and domain swapping experiments we showed that the transmembrane domains of PAQR-2 are responsible for its functional requirement for IGLR-2. Conversely, PAQR-1 itself does not require IGLR-2 for its function. The less conserved N-terminal cytoplasmic domains of PAQR-1 and PAQR-2 likely regulate the activity of these proteins, speculatively via a “ball and chain” mechanism similar to that found in certain voltage-gated channels.

We conclude that inhibition of membrane fluidity regulators, such as *fld-1* or *acs-13*, or a gain-of-function allele of *paqr-1* can suppress *paqr-2* mutant phenotypes through different mechanisms, which suggests that *paqr-2* regulates membrane fluidity in more than one way. Despite acting differently, the effects of these three mutations converge into lowering SFA levels while increasing the PUFA levels within phospholipids, and show that membrane homeostasis is likely essential for our ability to tolerate dietary saturated fats.

**Key words:** PAQR, LRIG, membrane fluidity, domain swapping, lipotoxicity, long chain polyunsaturated fatty acids

# Publications

This thesis is based on the following publications, referred to by their roman numerals in the text:

**I. Membrane Fluidity is Regulated by the *C. elegans* Transmembrane Protein FLD-1 and its Human Homologs TLCD1/2**

Ruiz M, Bodhicharla R, Svensk E, Devkota R, Busayavalasa K, Palmgren H, Ståhlman M, Boren J, Pilon M.,  
Elife. 2018 Dec 4;7. pii: e40686. doi: 10.7554/eLife.40686

**II. Evolutionarily Conserved Long-Chain Acyl- CoA Synthetases Regulate Membrane Composition and Fluidity**

Ruiz M, Bodhicharla R, Ståhlman M, Svensk E, Busayavalasa K, Palmgren H, Ruhanen H, Boren J, Pilon M.,  
Elife. 2019 Nov 26;8. pii: e47733. doi: 10.7554/eLife.47733

**III. Leveraging a Gain-of-Function Allele of *C. elegans* PAQR-1 to Elucidate Membrane Homeostasis by PAQR Proteins**

Busayavalasa K, Ruiz M, Devkota R, Ståhlman M, Bodhicharla R, Svensk E, Hermansson N, Boren J, Pilon M.,  
Submitted for publication

Papers not included in the thesis

**a. Meiosis I progression in spermatogenesis requires a type of testis-specific 20S core proteasome.**

Zhang Q, Ji SY, Busayavalasa K, Shao J, Yu C.  
Nat Commun. 2019 Jul 29;10(1):3387. doi: 10.1038/s41467-019-11346-y

**b. SPO16 binds SHOC1 to promote homologous recombination and crossing-over in meiotic prophase I.**

Zhang Q, Ji SY, Busayavalasa K, Yu C.  
Sci Adv. 2019 Jan 23;5(1):eaau9780. doi: 10.1126/sciadv.aau9780. eCollection 2019 Jan.

# Table of Contents

<b>Introduction</b> .....	<b>1</b>
<b>PAQR family and protein structure</b> .....	<b>1</b>
PAQR proteins in <i>Saccharomyces cerevisiae</i> .....	1
PAQR proteins in <i>Drosophila Melanogaster</i> .....	2
Mammalian AdipoRs .....	3
Crystal structure of the human AdipoRs.....	6
PAQR proteins in <i>Caenorhabditis elegans</i> .....	7
<b>Lipid metabolism in <i>C. elegans</i></b> .....	<b>8</b>
Types of <i>C. elegans</i> fatty acids.....	9
<i>de novo</i> synthesis of fatty acyl chains in <i>C. elegans</i> .....	10
PUFAs synthesis in <i>C. elegans</i> .....	10
Temperature adaptation .....	11
Glucose supplementation in <i>C. elegans</i> .....	11
<b>Metabolic fate of fatty acids</b> .....	<b>13</b>
Channeling of fatty acids .....	13
Acyl-CoA synthetases (ACS).....	14
<b>Homeoviscous adaptation</b> .....	<b>16</b>
A note on cholesterol.....	16
Proteins that sense membrane properties.....	17
DesK sensing of membrane fluidity .....	17
MGA2 in yeast .....	18
OPI1 sensing .....	18
SREBP1/2 cholesterol and PC sensing .....	18
PCYT1A membrane packing defects.....	19
IRE1 as an ER membrane stress sensor.....	19
<b>Methods</b> .....	<b>19</b>
Fluorescence recovery after photobleaching (FRAP) in <i>C. elegans</i> .....	19
Fluorescence recovery after photobleaching (FRAP) in HEK293 cells.....	20
Laurdan dye measurement of membrane fluidity in HEK293 cells.....	21
<b>Results and Discussion</b> .....	<b>21</b>
<b>Preview of the results and discussion</b> .....	<b>21</b>
PAPER I - Membrane fluidity is regulated by the <i>C. elegans</i> transmembrane protein FLD-1 and its human homologs TLCD1/2. ....	22
Discussion PAPER I.....	25
PAPER II - Evolutionarily conserved long-chain fatty acyl- CoA synthetases regulate membrane composition and fluidity .....	26
Discussion PAPER II.....	29
PAPER III- Leveraging a gain-of-function allele of <i>C. elegans</i> PAQR-1 to elucidate membrane homeostasis by PAQR proteins.....	30
Discussion PAPER III.....	33
<b>Future Perspectives</b> .....	<b>34</b>
<b>Acknowledgements</b> .....	<b>36</b>
<b>References</b> .....	<b>37</b>





# Introduction

The introduction to this thesis consists of several distinct sections. We begin with an overview of the PAQR family of proteins, i.e. the proteins in focus throughout this thesis which concerns their roles in lipid and membrane homeostasis. This will be followed by a description of lipid metabolism in *C. elegans*, i.e. the model organism most used throughout the thesis work. Overviews of fatty acids (FAs) and phospholipid homeostasis will then be presented, with a focus on several sensors and regulators of membrane properties. This will be followed by a presentation of the experimental work and key findings, then concluding remarks

## PAQR family and protein structure

The PAQR protein family was so named in 2005 (Tang et al., 2005), after the founding members, Progesterone and AdipoQ Receptors, that were initially identified as receptors for progesterone (Zhu et al., 2003a; Zhu et al., 2003b) and AdipoQ/adiponectin (Yamauchi et al., 2003a). Both progesterone and adiponectin receptor groups show seven predicted seven transmembrane (TM) domains with no sequence similarity to GPCRs, and these 7TM receptor groups are actually sequence paralogs that represent a new family of receptors unrelated to GPCRs. PAQR proteins are evolutionarily conserved from yeast to humans, *E. coli* (1), *Saccharomyces cerevisiae* (4), *C. elegans* (5), *Drosophila melanogaster* (5), and the human genome harbors at least 11 PAQR protein-coding genes (Tang et al., 2005; Yamauchi et al., 2003a). PAQR proteins have a conserved structure consisting of seven TM domains and an intracellular N-terminus and extracellular C-terminus (Figure 1). The following sections summarize findings on PAQR proteins in yeast, flies, mammals and finally in the nematode *C. elegans*.

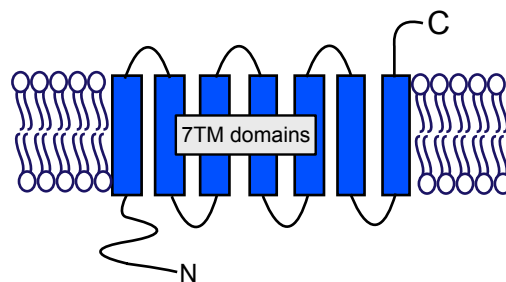

**Figure 1: Structure of PAQR proteins.** Diagram of a PAQR protein showing seven TM domains with the N-terminus facing the inside (cytoplasm) and the C-terminus facing the outside of the cell.

### PAQR proteins in *Saccharomyces cerevisiae*

There are four members of the PAQR family in *S. cerevisiae*, termed IZH1-4 (Lyons et al., 2004) amongst which *Izh2* is the most extensively studied. The yeast *Izh* (Implicated in Zinc Homeostasis) genes encode PAQR proteins that are similar to *C. elegans* PAQR-1 and PAQR-2 or to the human AdipoRs (AdipoR1 and AdipoR2). The *Izh2* gene contains a consensus ORE (Oleate Response Element) in its promoter region (Karpichev et al., 2002; Karpichev and Small, 1998). The ORE consists of CGG triplets that are separated by 15- to 18-nucleotides spacers. OREs are found in genes

essential for the proliferation of peroxisomes when supplied with a FA carbon source for growth. OREs act as a regulatory switch that can be bound by the transcription factors Oaf1p and Pip2p, which are functional homologs of mammalian peroxisome proliferator-activated receptors (PPARs) and Retinoid X receptors (RXRs). Expression of *Izh2* mRNA is induced upon glucose or saturated FA (SFA, e.g. stearic acid, 18:0) supplementation, strongly decreased in the presence of glycerol and fully silenced by a combination of glycerol plus oleic acid (OE, an unsaturated FA, UFA,18:1) supplementation (Karpichev et al., 2002; Karpichev and Small, 1998).

IZH2 activity represses the expression of *FET3* (a permease important for iron uptake) in a dose dependent manner (Kupchak et al., 2007). This effect is dependent on protein kinase A (PKA) and can be mirrored by the overexpression of human ADIPOR1 (in the same conditions), while ADIPOR2 required the presence of adiponectin in order to mimic the effect of IZH2 on *FET3* regulation (Kupchak et al., 2007). Repression of *FET3* has been used as a reporter to measure IZH2 activity and define its downstream signaling mechanism (Villa et al., 2009). IZH2 has sequence homology with alkaline ceramidases, which hydrolyze ceramides to generate free FAs (FFAs) and sphingoid bases (Villa et al., 2009). IZH2-dependent accumulation of sphingoid bases is likely the key signal from IZH2 since blocking their production using myriocin (an inhibitor of serine palmitoyltransferase that stops the production of sphingoid bases) impaired *Izh2*-dependent regulation of *FET3* (Yamaji-Hasegawa et al., 2005). The authors failed to detect *in vitro* ceramidase activity from the membrane preps of IZH2 overexpressing cells (Villa et al., 2009). However, a known inhibitor of alkaline ceramidase, *D-erythro*-MAPP did inhibit the activity of IZH2 in a *FET3* regulation assay (Kupchak et al., 2007; Villa et al., 2009). To summarize, *S. cerevisiae* PAQR protein IZH2 signals through an intrinsic ceramidase activity (Villa et al., 2009) and important findings related to this thesis are that *Izh2* expression in yeast is induced by glucose and SFAs but repressed by UFAs (Karpichev et al., 2002; Karpichev and Small, 1998). Our findings in *C. elegans* echoe some of these observations, as will be clear in later parts of the thesis.

### **PAQR proteins in *Drosophila Melanogaster***

dADIPOR (*Drosophila* adiponectin receptor) is an essential gene in *Drosophila*. dADIPOR is the *Drosophila* protein with the highest homology with human adiponectin receptor 1 and is highly expressed in several regions of the larva and adult fly brain, including the insulin producing cells (IPC). Partial knockdown of IPC-specific *dAdipoR* by RNAi results in several metabolic phenotypes such as increased levels of glucose in hemolymph, increased triglyceride levels in whole body, shorter life span, resistance to starvation and increased sensitivity to a high fat diet (Kwak et al., 2013). Since the *dAdipoR* null allele is lethal, mosaic flies have been generated to study the function of dADIPOR in germline stem cells (GSCs)(Laws et al., 2015). In these mosaic flies, loss of dADIPOR had no effect on the insulin dependent GSCs proliferation. However, diet-dependent GSCs proliferation was affected: on a rich diet, GSCs proliferated much faster and were more abundant (Laws et al., 2015). The cellular basis of the phenotypes, and the actual cause of lethality, in the dADIPOR null mutants are not well characterized.

## Mammalian AdipoRs

There are 11 PAQR proteins in the human genome, including AdipoR1 and AdipoR2, also known as human PAQR1 and PAQR2, respectively. The AdipoRs were initially discovered as candidate receptors for the adipocyte-produced serum protein adiponectin. Incidentally, several published studies have suggested that adiponectin may have anti-diabetic properties. In particular, there is an inverse correlation between serum levels of adiponectin and obesity, a strong risk factor for type-2 diabetes (Hu et al., 1996). Also, administration of adiponectin lowers plasma glucose levels and improves insulin resistance in mice (Fruebis et al., 2001; Yamauchi et al., 2001). Conversely, adiponectin-deficient mice exhibit insulin resistance and diabetes (Kubota et al., 2002; Maeda et al., 2002). Adiponectin may also have anti-atherogenic properties (Kubota et al., 2002; Yamauchi et al., 2003b; Yamauchi et al., 2001). These promising adiponectin studies suggested that it may be a hormone (an “adipokine”) and stimulated research into the nature of its signaling and a search for its receptor(s).

Fluorescent-labeled recombinant adiponectin fragments were used as baits in a screen of a human cDNA expression library in cultured cells, leading to the identification of candidate receptors, namely AdipoR1 and AdipoR2 (Yamauchi et al., 2003a). Both proteins are widely expressed, though AdipoR1 is most abundantly expressed in skeletal muscles whereas AdipoR2 is most expressed in liver (Yamauchi et al., 2003b). Being PAQR proteins, the adiponectin receptors have seven TM domains and are both structurally and functionally different from G-protein-coupled receptors. Human and mouse AdipoR1 share 96.8% identity whereas their AdipoR2s share 95.2% identity. Human and mouse AdipoR1 are located at chromosomal positions 1p36.13-q41 and 1E4, respectively, whereas the AdipoR2 genes are located at chromosomal positions 12p13.31 and 6F1 (Scheer et al., 1996; Wess, 1997; Yokomizo et al., 1997).

Mouse AdipoR1 encodes a protein of 375 amino acids whereas mouse AdipoR2 encodes a protein of 311 amino acids. Structurally, AdipoR1 and AdipoR2 share 66.7% identity. AdipoR1 was detected with the epitope tag haemagglutinin (HA) in anti-Flag antibody immunoprecipitation experiment containing Flag-tagged AdipoR1 and AdipoR2, which suggest that both these proteins may be able to form homo and heteromultimers (Yamauchi et al., 2003a). The tag epitopes were inserted at the amino-terminus and AdipoR1 and AdipoR2 were detected only when the cells were permeabilized. Conversely, epitope tags inserted at the carboxyl-terminus could be detected without cell permeabilization. These observations support the notion that AdipoR1 and AdipoR2 are membrane proteins and that their topology is opposite to that of normal GPCRs i.e. their N-terminus is inside, and their C-terminus is outside of the cell. Overexpression or suppression of AdipoR1 and AdipoR2 expression respectively mediate increase or decrease of AMPK, PPAR- $\alpha$  ligand activity, FA oxidation and glucose uptake, which appear consistent with their suggested roles as mediators of adiponectin effects (Yamauchi et al., 2003a).

Studies in mice suggest that functional differences exist between AdipoR1 and AdipoR2. In particular, AdipoR1 seems to predominantly acts via the AMPK pathway whereas AdipoR2 primarily acts via PPAR- $\alpha$  (Yamauchi et al., 2007). Physiologically, the activity of AdipoR1 and AdipoR2 would then stimulate FA oxidation via AMPK and PPAR- $\alpha$  pathways which in turn would decrease triglyceride levels. The effects of adiponectin, such as causing reduction in serum glucose levels, were abolished in

AdipoR1/2 double knockout mice (Yamauchi et al., 2007), which seems consistent with adiponectin acting via these proteins. T-cadherin, which is also expressed in the liver, is reported to be capable of binding to adiponectin; however, simultaneous disruption of AdipoR1 and AdipoR2 was sufficient to almost completely abolish adiponectin binding to the liver, which appears to be the major organ responsible for mediating the whole-body metabolic effects generated by adiponectin (Nawrocki et al., 2006; Yamauchi et al., 2001)

Not all studies on AdipoR1/2 KO mice show a clear link with diabetes, and there is indeed some controversy as to whether the AdipoRs are actually adiponectin receptors. The AdipoR1 knockout mice generated in the Kadowaki lab (with exons 2, 3 and 4 deleted) were viable and fertile with normal food intake and body weight. In contrast, the AdipoR1 knockout mice generated by the company Deltagen (San Carlos, CA; missing exon 2 and producing a frame-shift mutation) showed an increased adiposity phenotype due to decreased energy expenditure (Bjursell et al., 2007; Parker-Duffen et al., 2014). Also, the Deltagen AdipoR1 KO males and females have a normal insulin response and are insulin resistant on a high-fat diet (HF). Additionally, analysis of AdipoR1 KO mice (purchased from Taconic Biosciences, Germantown, NY) revealed a severe eye phenotype: defects in the accumulation of polyunsaturated FAs (PUFAs) in the photoreceptor cells of the retina were accompanied by abnormal retina morphology, decreased expression of retinal proteins, and impaired vision in adulthood (Sluch et al., 2018). A similar retina defect has been observed in human patients homozygous for an AdipoR1 *lof* mutation (Zhang et al., 2016).

A similar discrepancy exists regarding the AdipoR2 knockout mice. The AdipoR2 knockout mice generated by the Kadowaki group (with exon 3 deleted) were viable and fertile with normal body weight and increased levels of plasma insulin. Glucose levels were also normal. The AdipoR2 knockout mice generated by Deltagen (with exon 5 deleted) showed contrasting results: these mice have lower body weight and less body fat mass (Parker-Duffen et al., 2014), and showed resistance to weight gain, improved glucose tolerance and lowered insulin levels in the plasma when placed on a high fat diet (Bjursell et al., 2007; Liu et al., 2007).

The double AdipoR1/2 knockout mice generated by the Kadowaki group are viable (Yamauchi et al., 2007). This again is in contrast to the findings using the Deltagen AdipoR1/2 double knockout, which is embryonic lethal (Lindgren et al., 2013). It is therefore difficult to draw specific conclusions about the *in vivo* functions of the AdipoRs in mice because of the discrepancies between different mouse models generated by different labs. To resolve the discrepancies a newly generated knockout mice with new alleles could definitely help.

Previous knowledge about the yeast PAQR family proteins suggested that they have intrinsic ceramidase activity, which inspired investigations regarding a possible similar activity in the mammalian AdipoRs. The Lyons lab expressed human AdipoR1 or AdipoR2 in yeast cells and found that basal signaling by human AdipoR1, as well as ligand-dependent (they used globular adiponectin from Biovendor Laboratory Medicine) signaling from either human AdipoR1 or AdipoR2 is inhibited by the ceramidase inhibitor MAPP and by TNF $\alpha$  (Villa et al., 2009). Separately, the Scherer lab showed that expression of AdipoR1/2 in HEK293T cells increases ceramidase activity and that this effect can be further stimulated by the addition of adiponectin or

reduced by mutating the putative ceramidase domain (Holland et al., 2011). Importantly, the ceramidase activity cannot be stimulated by adiponectin in MEF (mouse embryonic fibroblasts) cells obtained from the AdipoR1/2 knockout mice (Holland et al., 2011). Additionally, *in vitro* studies with purified proteins have also shown that AdipoR1 and AdipoR2 possess intrinsic ceramidase activity, and that the AdipoR2 ceramidase activity is enhanced by the presence of adiponectin, though it had a very slow reaction rate even when adiponectin was present (Vasiliauskaite-Brooks et al., 2017).

Published studies from the Pilon group showed that the AdipoRs have adiponectin-independent functions, at least in the context of membrane composition homeostasis. Specifically, knockdown of AdipoR1 and AdipoR2 in HEK293 cells has no effect on membrane fluidity in basal conditions as determined by FRAP (Fluorescence recovery after photobleaching; this method measures the rate at which membrane-associated fluorescent probes replenish a specific laser-bleached area of the membrane) (Ruiz et al., 2019b). In contrast, when the cells were treated with 200  $\mu$ M palmitic acid (PA), AdipoR1 siRNA treated cells showed no or only a slight decrease in membrane fluidity whereas AdipoR2 siRNA treated cells showed a clear loss of membrane fluidity. This suggests that AdipoR2 is more important in protecting HEK293 cells against the rigidifying effects of PA. Inhibiting AdipoR1 and AdipoR2 together and then treating the cells with 200  $\mu$ M PA had the most dramatic effect on the membrane fluidity as measured by FRAP, suggesting some functional redundancy between the two proteins (Ruiz et al., 2019b). Adiponectin was not required for the AdipoR-dependent membrane fluidity homeostasis, and addition of exogenous adiponectin in different treatment conditions also had no effect.

The Laurdan dye method, which quantifies membrane order using a fluorescent dye that emits at different wavelengths depending on the presence of water molecule within the lipid bilayer (Owen et al., 2011), also confirms that there are membrane fluidity defects when AdipoR1 and AdipoR2 are silenced singly or together (Ruiz et al., 2019b). Importantly, and as we will soon cover in more details, the role of PAQR proteins in membrane homeostasis is conserved between *C. elegans* and human cells (Ruiz et al., 2019b), and possibly even in yeast cells (Mattiuzzi Usaj et al., 2015), suggesting that it is an ancestral function. siRNA against AdipoR1 and AdipoR2 causes HEK293 cells to have slightly more SFAs in their phospholipids under basal condition, and much more SFAs when challenged with 200  $\mu$ M PA. Increased SFAs in the phospholipids is at least in part due to the decreased expression of the most important desaturase genes: SCD, FADS1 and FADS2 expression was reduced in AdipoR2 siRNA-treated cells, while FADS1 and FADS2 expression was reduced in AdipoR1 siRNA-treated cells. (Ruiz et al., 2019b).

AdipoR1 and AdipoR2 maintain membrane fluidity not only in HEK293 cells but also in hepatocyte-derived HepG2 cells, in astrocyte-like 1321N1 cells and in human umbilical vein endothelial cells (HUVECs). Adiponectin, a proposed ligand for AdipoRs was never included in any of the FRAP and Laurdan dye experiments, suggesting again that the AdipoRs maintain membrane fluidity independently of adiponectin (Ruiz et al., 2019b).

## Crystal structure of the human AdipoRs

AdipoR1 and AdipoR2 seems to be required for the induction of 5'AMPK and PPAR- $\alpha$  when HEK293 cells are stimulated with adiponectin (Tanabe et al., 2015a). The crystal structures of human AdipoR1 and AdipoR2, done on recombinant proteins lacking the N-terminal cytoplasmic residues, were determined at 2.9 and 2.4 Å resolution, respectively. The N-terminal truncated constructs of human AdipoR1 and AdipoR2 (residues 89-375 and 100-386) exhibited better expression and purification properties compared to the full length, which is why they were used in these structure studies. However, they displayed the same extents of adiponectin-stimulated AMPK phosphorylation as the full-length proteins in HEK293 cells (Tanabe et al., 2015b).

Analysis of the crystals revealed structural and functional properties of the ADIPORs, including detailed description of the arrangement of the seven TM domains, the presence of a zinc-ion coordinating site, and a putative adiponectin-binding surface, which are all completely distinct from that of GPCRs. When viewed from outside of the cell, the 7TM domains are bundled and arranged circularly in clockwise manner. By X-ray absorption spectroscopy, it was found that a zinc ion is bound within the 7TM domains in both AdipoR1 and AdipoR2 structures. The zinc ion is coordinated by histidine residues in TM2 and TM7 and an aspartic acid residue in TM3. Adiponectin-stimulated AMPK phosphorylation in truncated AdipoR1 (89-375) transfected cells was reduced in a mutant protein where all the Histidine residues were replaced by Alanine residues. Interestingly, mutating any one individual amino acid involved in zinc coordination did not have a measurable effect on the AMPK-inducing activity, suggesting that they are individually dispensable (Tanabe et al., 2015a). Binding of the zinc ion is proposed to have a structure-stabilizing effect and may not be directly required for the adiponectin-stimulated AMPK phosphorylation. An attractive hypothesis that emerged from the structural analysis is that the AdipoRs have zinc-ion-facilitated hydrolytic activity, and uses the water molecule observed between the zinc ion and the side-chain carboxyl group of an amino acid in the catalytic site (e.g. Asp219 in helix III of AdipoR2) for the nucleophilic attack on the carbonyl carbon atom of substrates.

Similarly, adiponectin-dependent *UCP2* (uncoupling protein 2) upregulation in AdipoR2-positive cells was correlated with structural stabilization. Speculatively, the AdipoR2 hydrolytic activity may produce a FFA through lipid (e.g. ceramide) hydrolysis in a adiponectin-stimulated manner; a reaction product, perhaps the proposed FFA, may act as the activating ligand for PPAR- $\alpha$ , leading to expression of PPAR- $\alpha$  target genes, such as *UCP2* (Tanabe et al., 2015a). Because of the relatively poor quality of the electron density map in the first published report, a revised version of AdipoR1 crystal structure exhibiting seven transmembrane domain architecture that is distinct from the initially published structure (Vasiliauskaite-Brooks et al., 2017). In the updated AdipoR1 crystal structure, no FFA was observed within the barrel shaped cavity formed by the 7TM domains, and the ceramide binding and the putative zinc-coordinated catalytic site were exposed to the inner leaflet of the plasma membrane. A refined crystal structure of AdipoR2 was also produced and revealed the presence of a FFA within the large internal cavity. Vasiliauskaite-Brooks et al. modelled an oleic acid (C18:1) within the density map as it is the main UFA found in the Sf9 insect cell expression system used for the protein production (48.0%) and is present in a greater

amount than the main SFA stearic acid (C18:0, 17.9%) (Vasiliauskaite-Brooks et al., 2017). However, the actual functional substrate(s) for both AdipoR1 and AdipoR2 remains undefined.

In AdipoR2, there is a continuous uninterrupted cavity which is going through the entire receptor from the domain exposed to the upper lipid bilayer to the domain exposed to the cytoplasm. The upper lipid bilayer is linked to the FFA binding pocket via TM5 and TM6. Some electron density is present in this cavity, which indicates that this large opening might play a key role in modulating the entrance or exit of molecules (substrates and products) to or from this membrane-embedded enzyme. On the intracellular side of AdipoR2, the cavity splits into two, one of which is exposed to the cytoplasm and the other to the TM opening (Vasiliauskaite-Brooks et al., 2017).

### **PAQR proteins in *Caenorhabditis elegans***

*C. elegans* is a small (1 mm) nematode first introduced by Sydney Brenner in 1974 to study animal development and the nervous system (Brenner, 1974). The entire genome was sequenced and revealed that the similarity between the genes of *C. elegans* and humans is quite significant. In particular, at least 40% of the genes linked to human diseases have homologs in *C. elegans*. Since then, much effort leveraging both forward and reverse genetics approaches has been done to understand the function, regulation, interaction and expression of the *C. elegans* genes (Corsi, 2006).

Genome searches using human AdipoR1 as query identified 5 genes in *C. elegans* with significant homology (Svensson et al., 2011). The closest *C. elegans* sequence homologs of the human AdipoR1 and AdipoR2 are PAQR-1 and PAQR-2, whereas PAQR-3 is more similar to human PAQR3, and the remaining two *C. elegans* genes are clearly outgroups. *C. elegans paqr-1,-2* and *-3* have seven exons and encode proteins with seven predicted TMs (Svensson et al., 2011). *paqr-1* is expressed in several tissues, including pharyngeal gland cells, excretory canal cell, vulva muscle, gonad sheath cell, intestine and occasionally in body muscles. *paqr-2* is expressed most predominantly in gonad sheath cells, in head ganglion neurons, head muscle cells, pharyngeal M2 neurons, seam cells, ventral nerve cord and tail neurons, and occasionally in body muscles and intestine. *paqr-3* is expressed in the hypodermal cells, duct cells, rectal gland, gonad sheath and vulva cells (Svensson et al., 2011).

The *paqr-1 (tm3262)* and *paqr-3 (ok2229)* are most likely null alleles and do not have clear phenotypes by themselves, whereas the *paqr-2 (tm3410)* null mutant has a withered tail tip phenotype that is visible from the L4 stage (Svensson et al., 2011), cold sensitivity (cannot grow at low temperatures such as 15°C) (Svensk et al., 2013) and glucose intolerance (Svensk et al., 2016b). *paqr-2* mutants also have several other defects such as reduced brood size, locomotion, pharyngeal pumping rate and life span (Svensson et al., 2011). *paqr-2* is therefore the most important amongst the *C. elegans paqr* genes studied so far. Note however that the function of *paqr-2* is partially redundant with that of *paqr-1* since the phenotypes (e.g. growth rate, brood size, life span) in the *paqr-1;paqr-2* double mutants are much more severe than in the *paqr-2* single mutant (Svensson et al., 2011).

Several lines of evidence suggest that *paqr-2* adaptively promotes the activity of  $\Delta 9$  desaturase during cold adaptation via either *sbp-1* or *nhr-49* (transcription factors that

govern fat metabolism). In particular, the *paqr-2* mutant has a marked decrease in *fat-7* (a  $\Delta 9$  desaturase) expression. Similarly, the *nhr-49* (*gk405*) null mutant has very low *fat-7* expression. In contrast, worms carrying the *nhr-49* (*et8*) allele, a gain of function (*gof*) allele isolated in a *paqr-2* suppressor screen, show increased *fat-7* expression and, importantly, *paqr-2 nhr-49* (*et8*) double mutants also exhibit high *fat-7* expression levels (Svensk et al., 2013). *sbp-1* encodes the single SREBP homolog in worms, and the partial *lof* allele, *sbp-1(ep79)* is viable as a single mutant but lethal in combination with a *paqr-2 lof* mutation. Furthermore, the double mutant *paqr-2;nhr-49* (*gk405*) is synthetic lethal but can be suppressed by *cept-1(et10)*, a mutation that impairs the synthesis of phosphatidylcholines (PCs); in contrast, the *paqr-2;sbp-1(ep79)* lethality cannot be suppressed by *cept-1(et10)* nor, incidentally, by *nhr-49* (*et8*). This suggests that *cept-1* may act through *sbp-1*. Indeed, *lof* mutation in enzymes involved in PC synthesis, such as *cept-1*, suppress the cold adaptation phenotype of *paqr-2* mutant by increasing the expression of  $\Delta 9$  desaturases. This is consistent with the published observation that depletion of PC synthesis enzymes (e.g. *sams-1*, *pmt-1*, *cept-1*, *pcyt-1*), stimulates *sbp-1* which in turn activate *fat-7* (Walker et al., 2011). Furthermore, inhibiting the *C. elegans* desaturases using RNAi abolishes the ability of *nhr-49(et8)* to act as a *paqr-2* suppressor. Additionally, lipidomics analysis shows that *paqr-2* mutants have an excess of SFAs in phospholipids while *paqr-2* suppressor mutant alleles of *pcyt-1*, *nhr-49*, *mdt-15* reduce the SFA levels in the phospholipids of *paqr-2* mutant worms (Svensk et al., 2013). Altogether, these studies suggest that *paqr-2* is required for the adaptive induction of desaturases leading to a decreased SFA content in phospholipids at low temperatures.

PAQR-2 activity is strictly dependent on the presence of its dedicated partner IGLR-2 (immunoglobulin domain and leucine-rich repeat-containing protein 2) which was discovered in a *paqr-2* genocopier screen i.e. a screen to identify genes that, when mutated, cause the same phenotypes as in *paqr-2* mutants. *iglr-2* is a true *paqr-2* genocopy: the *iglr-2* mutant has exactly the same phenotypes as the *paqr-2* mutant, including cold intolerance, glucose intolerance, and withered tail tip (Svensk et al., 2016b). Furthermore, bimolecular fluorescence complementation (BiFC) experiments have shown that the PAQR-2 protein interacts with IGLR-2 and that this interaction is important for regulating membrane fluidity when cultivated in cold or in the presence of glucose (Svensk et al., 2016b). IGLR-2 is related to mammalian leucine-rich repeats and immunoglobulin-like domains (LRIG) proteins, a family with approximately 40 members in human genome, and the human functional homolog of IGLR-2, if there is one, is yet to be identified.

## Lipid metabolism in *C. elegans*

Lipids are small organic molecules that are insoluble in water, but soluble in organic solvents. Many lipids, i.e. fats, are also well known as energy storage molecules. Lipid biosynthesis takes place in the endoplasmic reticulum (ER) (Bell et al., 1981). Lipids, in particular phospholipids and cholesterol, are the predominant hydrophobic units of membrane bilayers, and many lipids also act as potent signaling molecules. The variety of lipid species contributes to cellular and organellar functions. The lipid composition of the plasma membrane differs from that of other organelle such as ER, mitochondria and others (van Meer et al., 2008). It is believed that the lipid irregularity across the cellular compartments is important for distinct cellular functions (de Mendoza and Pilon, 2019; Watts and Ristow, 2017)



The primary components of eukaryotic membranes are phospholipids (de Mendoza and Pilon, 2019). Naturally occurring phospholipids, here specifically glycerophospholipids, are composed of a hydrophilic glycerol 3-phosphate-derived head group at the sn-3 position and two FAs attached at the sn-1 and sn-2 positions; the sn-2 position is often occupied by an UFA (Hanahan et al., 1960; Yabuuchi and O'Brien, 1968). The length of the FAs can also vary between 16 and 25 carbons, and the degree of unsaturation influences the nature and properties of fatty acids (Figure 2). Importantly, especially in the context of this thesis, SFAs (no double bond) can pack tightly within membrane and therefore promote membrane rigidity. Conversely, mono-unsaturated (one C-C double bond) and poly-unsaturated fatty acids (two or more C-C double bonds), i.e. MUFAs and PUFAs (PUFAs are highly twisted by the presence of multiple cis-double bonds) do not easily pack in ordered fashion and therefore act as membrane fluidizers. The hydrophilic head group can have a relatively large moiety such as choline or a relatively small one such as ethanolamine, forming cylindrical phosphatidylcholines (PCs) and conical phosphatidylethanolamine (PEs), respectively. In eukaryotic membranes, PCs account for >50% because they pack more easily and tend to form flat membrane structures. High levels of PEs in a membrane can result in packing gaps mainly due to the small head group relative to bulky acyl chains (de Mendoza and Pilon, 2019). Other abundant component of eukaryotic membranes are sterols, and more specifically cholesterol. Sterols can increase membrane fluidity when inserted into phospholipids that are rich in saturated fatty acids (Boumann et al., 2006) or reduce fluidity when inserted in membranes rich in UFAs where they can fill packing defects (Subczynski et al., 2017).

The nematode *C. elegans* has become an important tool for exploring the genetic basis of fatty acid synthesis and fat storage (Watts, 2009). The major metabolic organ for *C. elegans* is the intestine (Srinivasan, 2015), though the hypodermis is also a site of lipid storage (Morck et al., 2009). Additionally, other tissues must be metabolically quite active, including the gonad (oocyte biogenesis), muscles (energy utilization for mechanical work) and neurons (neurotransmitter release and recycling). Lipid profiling studies show that *C. elegans* fat are stored predominantly as triglycerides, which consists of three fatty acid chains anchored to a glycerol backbone (Srinivasan, 2015). FAs obtained from the bacterial diet (*E. coli*) are readily converted to triglycerides (Dancy et al., 2015).

### **Types of *C. elegans* fatty acids**

FAs are the building blocks and precursors for storage lipids, membrane lipids and signaling lipids. *C. elegans* FAs contain 14 to 20 carbons long aliphatic chains. *C. elegans* double bonds are methylene interrupted and 'cis' configured which means the double bonds are spaced in intervals of three carbons (Watts and Ristow, 2017). *C. elegans* has the ability to synthesize a range of monomethyl and polyunsaturated fatty acids starting with acetyl-CoA or isobutyryl-CoA. In contrast, most animals must obtain PUFAs from their diet because they lack the enzymes to convert MUFAs to PUFAs. *C. elegans* obtain FAs either from the diet (*E. coli* strain OP50) or synthesize *de novo*. In the laboratory, *C. elegans* obtains approximately 80% of its FAs from the OP50 diet with an exception of monomethyl fatty acids which are completely *de novo* synthesized (Perez and Van Gilst, 2008). It has been reported that *C. elegans* membrane FAs are continually and extensively replaced (Dancy et al., 2015): approximately, 4.5% of membrane fatty acid and 2.7% of storage lipids are replaced every hour. The *E. coli*

strains OP50 and HT115 membranes are composed of approximately 37% SFAs (31% of 16:0, 6% of 14:0 and trace amount of 18:0), 11% of MUFAs (11% of 18:1n-7 and trace amount of 16:1n-7) and 49% cyclopropane FAs (Brooks et al., 2009). None of these *E. coli* strains can produce PUFAs (Watts and Ristow, 2017). FAs in worm populations can be analyzed using acidic methylation to form acid methyl esters, which are separated from each other by gas chromatography (GC) and detected by mass spectrometry (Watts and Browse, 2002). This type of analysis, which generates a quantitative description of various lipids in a sample, is often simply referred to as “lipidomics”.

### ***de novo* synthesis of fatty acyl chains in *C. elegans***

The *de novo* synthesis of FAs is achieved through the activity of FA synthase (FAS, encoded by FASN-1) using acetyl-CoA as a starting substrate. The rate limiting step in *de novo* FA synthesis is the conversion of acetyl-CoA into malonyl-CoA by *pod-2*, a homolog of acetyl-CoA carboxylase (ACC) (Rappleye et al., 2003). After seven cycles of condensation of malonyl-CoA by FAS, palmitic acid (PA; C16:0) is synthesized. Malonyl CoA is used as substrate for the elongation of FAs using the ELO-1, ELO-2 and ELO-3 elongases, the LET-767 dehydratase and the HPO-8 beta-hydroxyacyl dehydratase. Synthesis of monomethyl branched chain fatty acids requires ACC and FAS, which is similar to the synthesis of straight chain FAs, except for the substrate, which is isovaleryl-CoA derived from branched chain amino acid leucine (Kniazeva et al., 2004).

*C. elegans* lipids contain abundant amounts of MUFAs, especially *cis*-vaccenic acid (18:1n-7), which is obtained directly from the *E.coli* diet. Additionally, SFAs can be desaturated to MUFAs by  $\Delta 9$  desaturases, worm homologs of mammalian stearoyl-CoA desaturases.  $\Delta 9$  desaturases insert the first double bond at carbon 9 of a SFA. *C. elegans* has three  $\Delta 9$  desaturases, namely FAT-5, FAT-6 and FAT-7. FAT-5 is specifically used for the conversion of 16:0 to 16:1n-7, which further can be elongated to 18:1n-7 (*cis*-vaccenic acid) (Watts and Browse, 2000). FAT-6 and FAT-7 desaturases act mainly on 18:0, producing 18:1n-9 (oleic acid, OA). Unlike in mammals, *C. elegans* can further elongate 18:1n-9 into PUFAs. OA is less abundant in *C. elegans* membranes than in mammalian membranes (Wallis et al., 2002). Mutant worms lacking all the three desaturases are synthetic lethal (Brock et al., 2006) and hence endogenous production of MUFAs is essential. In mammals, OA acts as substrate for acetyl transferases that synthesizes triglycerides (Cases et al., 2001) whereas in *C. elegans* triglyceride FAs consists of dietary FAs from *E.coli* (Perez and Van Gilst, 2008).

### **PUFAs synthesis in *C. elegans***

*de novo* PUFA synthesis is a unique aspect of *C. elegans* FA metabolism. There are two types of  $\Delta 12$  desaturases in *C. elegans* namely FAT-1 and FAT-2. FAT-2 converts MUFAs into PUFAs, for example 18:1n-9 (OA) into 18:2n-6 (linoleic acid, LA), whereas FAT-1 catalyzes the conversion of 18-carbon and 20-carbon omega-6 FAs into omega-3 FAs (Peyou-Ndi et al., 2000; Spsychalla et al., 1997; Watts and Browse, 2002). The *C. elegans*  $\Delta 5$  desaturase FAT-4 and  $\Delta 6$  desaturase FAT-3 are homologs of human FADS1 and FADS2, respectively (Napier et al., 1998; Watts and Browse, 1999). PUFAs comprise 28% of FAs in total worm lipids. The most abundant PUFA in *C.*

*C. elegans* is eicosapentaenoic acid (EPA, 20:5) and its levels increase during fasting (Van Gilst et al., 2005). PUFA-depleted *fat-2* mutants are viable (likely because they still have some amounts of PUFAs e.g. 20:5n3 that makes up 1.9% of all FAs), but exhibit many growth, reproduction and neurological defects (Watts and Browse, 2002). *fat-2* mutants have large amounts of OA and only 1% PUFA. *fat-3* mutants contain large amounts of 18-carbon long PUFAs but not of 20-carbon long PUFAs (Lesa et al., 2003; Watts et al., 2003). These mutants grow better and display higher brood size than *fat-2* mutants, but show many defects compared to wild type worms. *fat-4* and *fat-1* mutants have different species of PUFAs and greatly different ratios of omega-6 and omega-3 although growth, movement, and reproduction are essentially normal (Watts and Browse, 2002).

As mentioned earlier, glycerophospholipids are the major constituents of biological membranes. They are synthesized in the de novo pathway (Kennedy pathway), and the fatty acyl composition at the *sn-2* position can be altered via the Lands remodeling pathway (Lands cycle) (Lands, 2000; Shimizu, 2009; Shindou and Shimizu, 2009). Turnover of the *sn-2* acyl moiety of glycerophospholipids is achieved by the coordinated action of phospholipase A<sub>2</sub>s (PLA<sub>2</sub>s) and lysophospholipid acyltransferases (LPLATs) (Lands, 2000; Shindou and Shimizu, 2009). Membrane diversity is important to modulate the fluidity and curvature of the various cellular membranes and results from the overlapping reactions of multiple LPLATs that recognize various acyl-CoAs and polar head groups of lyso-glycerophospholipids in the remodeling pathway (Shindou and Shimizu, 2009).

### Temperature adaptation

*C. elegans* contains very low levels of SFAs, (5% of 16:0, 6% of 18:0 and <2% of 14:0) (Tanaka et al., 1996; Watts and Browse, 2002) which is likely adaptive to growth in cool environments. Indeed, cold adaptation in *C. elegans* relies on the induction of *fat-7* at cold temperatures (Murray et al., 2007), which is dependent on the activity of PAQR-2 and IGLR-2 (Svensk et al., 2016b; Svensk et al., 2013). At low temperatures, PAQR-2 and IGLR-2 appear to sense membrane rigidification, become activated and signal to induce the expression of desaturases. The importance of FA desaturation during cold adaptation is evidenced by the fact that *C. elegans fat-6;fat-7* and *fat5;fat7* double mutants accumulate high levels of SFAs and are cold sensitive (Brock et al., 2007). Other cold-tolerant and cold-sensitive mutants such as *age-1* (Savory et al., 2011), *paqr-2* (Svensson et al., 2011) and *iglr-2* (Svensk et al., 2016b) also influence the activity of Δ<sup>9</sup> desaturases. The role of membrane remodelling during heat adaptation in *C. elegans* has also been investigated (Tanabe et al., 2015a) and it appears that at high temperatures (25°C) ACDH-11 may sequester C11/C12-chain FAs proposed to act as NHR-49 ligands, and thus prevent the activation of NHR-49 and activation of *fat-7* expression (Tanabe et al., 2015a).

### Glucose supplementation in *C. elegans*

*C. elegans* can tolerate high amounts of glucose in its environment. Concentrations as high as 250 mM, supplemented in the culture plates has no effect on the brood size (Mondoux et al., 2011). However, 2% glucose (111 mM) does shorten the life span of wild type worms due to the inhibition of the activities of the transcription factors DAF-16 (FOXO) and of the heat shock factor HSF-1. Glucose supplementation also results

in the downregulation of an aquaporin glycerol channel, *aqp-1*, which also contributes to the decreased lifespan (Lee et al., 2009). The dauer-like phenotype of insulin receptor *daf-2* partial *lof* mutants is suppressed by glucose supplementation, likely because glucose activates the insulin signalling pathway in *C. elegans* and prevents *daf-16* induction of *aqp-1* (Lee et al., 2009). Additionally, some or all of the effect of glucose on life span may be via conversion to glycerol since the life span of wild type worms is shortened when supplemented with glycerol, which may lead to osmotic imbalances that can be countered by *aqp-1* induction (Lee et al., 2009). Separate studies found that the *C. elegans paqr-2* mutants cannot tolerate the presence of glucose in the culture plate, becoming growth-arrested in the presence of as little as 4 mM glucose. However, this is true only when the mutant is grown on a diet of *E. coli* that is competent in glucose uptake and its conversion into SFAs. Hence *paqr-2* mutants are insensitive to glucose when fed an *E. coli* strain carrying a  $\Delta$ PPTS mutation that prevents glucose uptake (Devkota et al., 2017). Indeed, *E. coli* metabolism that converts precursors into SFAs accounts for the toxicity of several dietary metabolites (e.g. glycerol, pyruvate, lactose, etc.) in the *paqr-2* mutant (Devkota et al., 2017).

Some additional considerations regarding the effect of glucose will now be discussed, in an effort to separate more directly the effects on *C. elegans* lifespan versus the indirect (i.e. via *E. coli* metabolism) effects on membrane composition. In a genetics approach to define the effects of glucose on lifespan, mutations in the sterol regulatory element-binding protein (SREBP) and mediator-15 were found to have life shortening effects of glucose-rich diets in *C. elegans* (Lee et al., 2015). Conversely, up-regulation of MDT-15 or SREBP restored normal life span in glucose-fed conditions. MDT-15, is a subunit of the mediator complex that acts as transcriptional co-activator for both SBP-1 and NHR-49 (Taubert et al., 2006; Yang et al., 2006). RNAi against *sbp-1* or the mediator subunit *mdt-15* further enhances the reduction of lifespan upon glucose supplementation, suggesting that they have a protective function against direct glucose effects in worms (Lee et al., 2015). Expression of the desaturases is induced by glucose feeding and promotes increased levels of fat storage, which may protect against toxic byproducts of glycolysis (Lee et al., 2015). In particular, dihydroxyacetonephosphate (DHAP), a metabolite produced during glycolysis, mediates a reduction of lifespan similar to that of glucose, and RNAi against *aldo-1* or *aldo-2* (enzymes required for the production of DHAP) is protective with respect to the reduction of lifespan (Lee et al., 2015). Altogether, these results and the earlier consideration on *daf-2*, suggest that glucose may exert two separate direct effects on worm metabolism: 1) glucose may activate insulin signaling, which represses DAF-16-dependent longevity processes such as protection against glycerol-related osmotic stress, and 2) glucose may be converted to toxic DHAP which also contributes to reduced life span. The case of the *paqr-2* mutant adds a third negative effect of glucose, i.e. its conversion to SFAs by the dietary bacteria that leads to accumulation of excessive amounts of SFAs in membrane phospholipids of the mutant and results in debilitating reduced membrane fluidity (Svensk et al., 2016b).

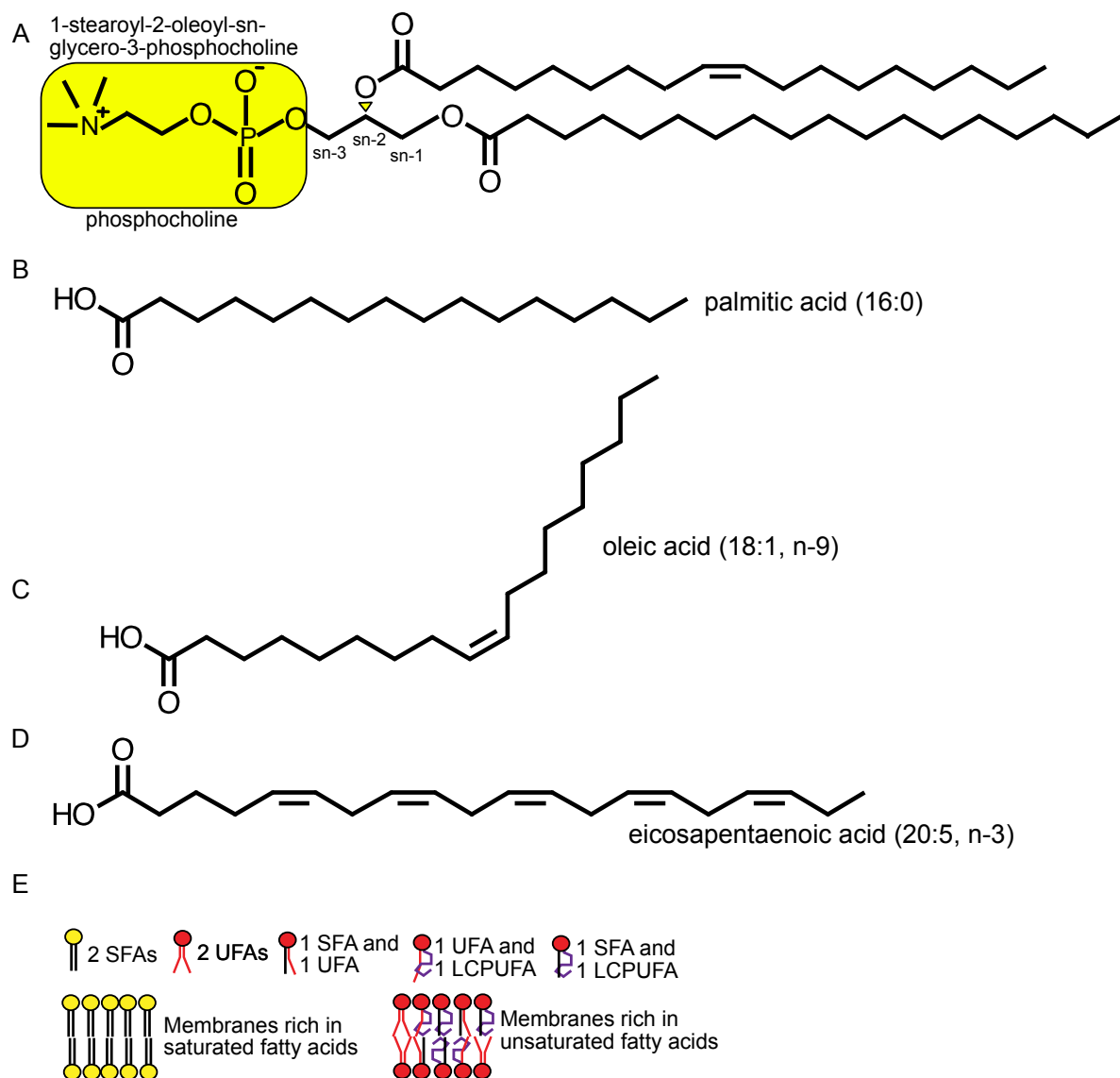

**Figure 2: Phospholipids and membranes.** (A) Structure of a phospholipid, with a hydrophilic head group highlighted in yellow, at sn-1 position there is a saturated fatty acid, at sn-2 position there is a unsaturated fatty acid and at sn-3 position there is the hydrophilic head group. (B-D) Examples of FAs (fatty acids), including one SFA (saturated fatty acid; palmitic acid), one MUFA (monounsaturated fatty acid; oleic acid) and one VLCPUFA (very long chain polyunsaturated fatty acid; eicosapentaenoic acid). (E) Membrane composition, rich in saturated fatty acid or unsaturated fatty acid.

## Metabolic fate of fatty acids

### Channeling of fatty acids

Long chain fatty acids (LCFAs) that are synthesized *de novo* or obtained from the diet can have multiple fates. The possible fates of these LCFAs include entry into:

- Degradation pathway ( $\beta$ -oxidation,  $\omega$ -oxidation)
- Phospholipid synthesis (Kennedy pathway and Lands cycle), TAG, Ceramide
- FA modification (elongation, desaturation and shortening)

- d. Transcriptional regulation (can act as a ligand)
- e. Esterification of proteins

LCFAs can also participate in intracellular signaling, which may be of particular relevance in this thesis since they may mediate PAQR-2 signaling. For example, FFAs can act as ligands for nuclear transcription factors and the 20 carbon long FAs can be converted into a variety of signaling eicosanoids.

LCFAs are activated by one of the 13 acyl-coenzyme A (acyl-CoA) synthetase (ACS) isoforms (more on this below). The long chain acyl-CoA acts as substrates for beta-oxidation or can be incorporated into complex lipids or used to modify proteins (Grevengoed et al., 2014). The long chain ACS activate fatty acids in a two-step reaction that uses the equivalent of two high energy bonds

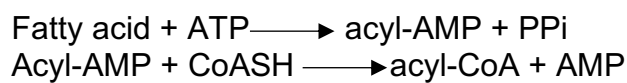

Long chain acyl-CoAs are excellent detergents because of their amphipathic nature and arrange themselves in spherical form in aqueous solutions with the CoA group exposed to water phase (Fullekrug et al., 2012). Within the cells, the CoAs are bound to proteins and membranes and thus the chance of self-aggregation is low. Different long-chain ACS isoforms channel their LCFA substrates into specific downstream pathways. Transport of fatty acid into the cells remains controversial but it has been speculated that FA entry might occur via the junctions between plasma membrane and ER or else the transport may be mediated by FA binding protein (FABP) (Fullekrug et al., 2012). Several research groups have shown that the FA entry is itself driven by the metabolism of the FAs (Black and DiRusso, 2003; Fullekrug et al., 2012). Amphipathic fatty acyl-CoAs can move freely in the cytosol and in the membrane monolayers. FABP and acyl-CoA binding protein (ACBP), assist the fatty acid and acyl CoA movement within the cells and protect cell membranes from the detergent effect of the acyl-CoAs.

During low energy levels, acyl-CoAs are transported into mitochondria by CPT1 (Carnitine palmitoyltransferase 1). The major route of FA degradation is mitochondrial  $\beta$ -oxidation. Additionally, very long chain FAs and branched chain FAs that are poorly oxidized in mitochondria are instead mostly degraded in peroxisomes (Hunt et al., 2012). The  $\beta$ -oxidation capability of peroxisomes produces chain-shortened acyl CoAs and acetyl-CoAs and propionyl-CoAs that are transported outside the peroxisomes as acyl-carnitines to then be completely oxidized within mitochondria (Hunt et al., 2012). Carnitine acetyltransferase, a peroxisomal enzyme, is responsible for converting the acyl CoA to carnitine esters that can be imported into mitochondria (Farrell et al., 1984).

### **Acyl-CoA synthetases (ACS)**

The ACS family includes 26 enzymes that have significant sequence homology with conserved domains corresponding to ATP/AMP binding sites and an FA binding site (Watkins et al., 2007). Crystallization studies in yeast and bacteria suggest that binding of ATP to the enzyme induces a conformational change that gives access to the FA binding site. Once the binding happens, FA is converted into FA-AMP. CoA is then bound to the FA-AMP and AMP is removed. Short chain acyl-CoA synthetases (ACSS) activate acetate, propionate and butyrate. Medium chain acyl-CoA synthetases

(ACSM) activate 6 to 10 carbon long FAs. Long chain acyl-CoA synthetases (ACSL) activate 12 to 20 carbon long FAs. Very long chain acyl-CoA synthetases (ACSVL) activate FAs longer than 20 carbon. ACS isoforms have been found in a variety of sub-cellular membrane compartments. For example, ACSL1 can localize to the plasma membrane, ER, mitochondria, nucleus, peroxisomes, lipid droplets and GLUT-4 vesicles (Lewin et al., 2001). ACSL3 is localized in lipid droplets and ER and might be responsible for both FA uptake and glycerolipid biosynthesis (Poppelreuther et al., 2012). ACSL4 is localized to the ER, mitochondrial-associated membranes and peroxisomes (Milger et al., 2006). ACSL5 is localized to mitochondria (Lewin et al., 2001).

To further complicate matters, different cell types can also have different localization of ACSLs (Soupene and Kuypers, 2008). For example, ACSL1 in liver has been found on the ER and mitochondria whereas the cardiac ACSL1 is localized only on mitochondria. Some specific functions related to these sites have been investigated (Lewin et al., 2001). For example, overexpressing ACSL1 specifically on mitochondria increases FA uptake and retention by 40%. The fate of fatty acyl CoAs, i.e. their “channeling”, is determined by the localization of the ACSL and the nature of its protein interaction partners. For example, ACSL1 coimmunoprecipitates with CPT1 (carnitine palmitoyltransferase-1) on the outer mitochondrial membrane; CPT1 catalyzes the conversion of acyl-CoA to acyl-carnitine, which is required for the FA transfer into the mitochondrial matrix for oxidation (Lee et al., 2011).

ACSL1 is the most extensively studied isoform and expressed highly in liver, heart, as well as white and brown adipose tissues (Durgan et al., 2006). Tissue specific knockout of ACSL1 shows that it has different functions in different tissues. In liver, ACSL1 is localized both on ER and mitochondria, and liver-specific KO of ACSL1 causes only a 20% decrease in the incorporation of OA into TAG. Although incorporation of OA into phospholipids is not affected, an analysis showing altered phospholipid species suggests that ACSL1 specifically contributes to the incorporation of 18:0-CoA into phospholipids (Li et al., 2009). Liver acyl-carnitines are 50% lower in ACSL1-deficient mice, it was concluded that lack of ACSL1 in liver impairs trafficking of acyl-CoAs in both TAG and oxidation pathways (Li et al., 2009). ACSL1 in liver either does not target its acyl-CoA product into a specific pathway or because of its dual location on both the mitochondria and the ER, ACSL1 partitions its product into both synthetic and degradative pathways. Tissue-specific KO of ACSL1 in highly oxidative tissues such as heart or white or brown adipose suggests that channeling towards  $\beta$ -oxidation is a primary function of ACSL1 in these tissues. In other tissues the KO causes 80-90% decrease in total long chain acyl-CoA synthase activity accompanied by decreased FA oxidation. In these KO models there is no alteration of incorporation of [ $^{14}$ C]oleate into TAG or phospholipid. In heart-specific ACSL1 KO mice, uptake of FA analog of PA is lower than in controls whereas uptake of glucose increases eightfold. In brown adipose tissue-specific ACSL1 KO mice, the defect in FA oxidation impairs the ability of the mice to maintain a normal body temperature when they are placed at 4°C (Grevengoed et al., 2014). Unlike the deficiency in liver, adipose tissue and heart tissue, ACSL1 deficiency in macrophages did not impair either FA oxidation or the accumulation of neutral lipids (Kanter et al., 2012a) but rather caused a reduction in the levels of 20:4 $\omega$ 6-CoA and blocked the increased production of prostaglandin E<sub>2</sub> (PGE<sub>2</sub>) that is usually observed in mice with type I diabetes. It was speculated that this finding was the result of either limited uptake and activation of 20:4 accompanied by depletion of

the membrane phospholipid pool available as a substrate for phospholipase A2 (Kanter and Bornfeldt, 2013) or was caused by lack of ACSL1-mediated activation of 18:2 as a substrate for the elongation and desaturation enzymes that convert 18:2-CoA to 20:4-CoA (Kanter et al., 2012b)

## Homeoviscous adaptation

While mammals and other homeotherms do not need to adjust membrane fluidity upon change in ambient temperature, poikilotherms constantly adjust their membrane composition to achieve membrane fluidity homeostasis (“fluidity” is here used as a general term typically reflecting loose membrane packing, rapid lateral mobility of membrane components and thinner span across the membrane due to interdigitating FA tails). At low temperatures, which promote membrane rigidification, increasing the proportion of unsaturated fatty acids and PE head groups contributes to maintaining membrane fluidity (Marr and Ingraham, 1962; Pruitt, 1988). Some organisms, also incorporate branched chain fatty acids into their membrane lipids, which also promotes phospholipid packing defects, i.e. fluidity (Suutari and Laakso, 1992). The fruit fly *Drosophila* adapts to changes in temperature, by adjusting not only the proportion of SFAs and UFAs but also by modulating the PC/PE ratio (Overgaard et al., 2008). An additional point of interest for this thesis is that neither *C. elegans* (Merris et al., 2003) nor *Drosophila* has the capacity to synthesize cholesterol, a lipid that greatly influence the fluidity of membranes in mammals (Yeagle, 1985). Finally, and as an interesting side note, the homeoviscous adaptation response has been studied extensively not only in response to temperature changes, but also in the context of adaptation to high hydrostatic pressure in deep sea fish, which also involves modulation of membrane fluidity (Hazel, 1984).

### A note on cholesterol

Cholesterol is an abundant but unevenly distributed component of cell membranes in mammalian cells. Higher concentrations of cholesterol are present in the plasma membrane compared to the many intracellular membranes. As noted earlier, the impact of cholesterol is bi-directional: higher levels of cholesterol can render membranes less flexible and simultaneously prevent tight packing of SFA-rich domains within the membrane, promoting fluidity (Yeagle, 1985). Also as noted earlier, *C. elegans* do not use cholesterol for structural purposes but rather use it as a precursor for signaling molecules (Matyash et al., 2001; Merris et al., 2003). Indeed, *C. elegans* lack the ability to synthesize cholesterol (Vinci et al., 2008), and instead must absorb sterols from the diet. In laboratory conditions, *C. elegans* are routinely grown in the presence of low concentrations of cholesterol. Experiments with depleted cholesterol show that very small amounts of cholesterol are required for larval growth. Using organic solvent-extracted agar, which removes traces of sterols, *C. elegans* grow normally for one generation and then arrest as larvae during the second generation; this growth arrest can be prevented by supplementing the cultures with small amounts (too small to play significant structural roles) of cholesterol. These results indicate that sterols are essential for *C. elegans* development but not as structural components of membranes (Vinci et al., 2008); this simplifies biochemical analysis of membrane composition in *C. elegans* since cholesterol is not a factor..



## Proteins that sense membrane properties

A protein that is influenced by the membrane environment can act as a membrane property sensor and, if linked to an effector/signaling component, could support a membrane homeostatic response. Membrane sensors are either integral membrane proteins or soluble proteins that associate reversibly with the membrane to explore surface properties (Ernst et al., 2016). According to Ernst and colleagues, there are three sensor classes: class I sensors interact with membrane surfaces and sense, for instance, lipid packing defects, membrane curvature, and/or the surface charge density; class II sensors are transmembrane proteins sensing in the hydrophobic membrane core; class III sensors have transmembrane regions that bend, squeeze, or stretch the lipid bilayer to sense its mechanical properties. This classification is not limited, since some sensors might belong to more than one class (Covino et al., 2018). An overview of well-studied sensor proteins in different organisms is presented in Fig.3, and some of the best understood ones will be briefly described in order to provide a context for our findings on PAQR-2 and IGLR-2.

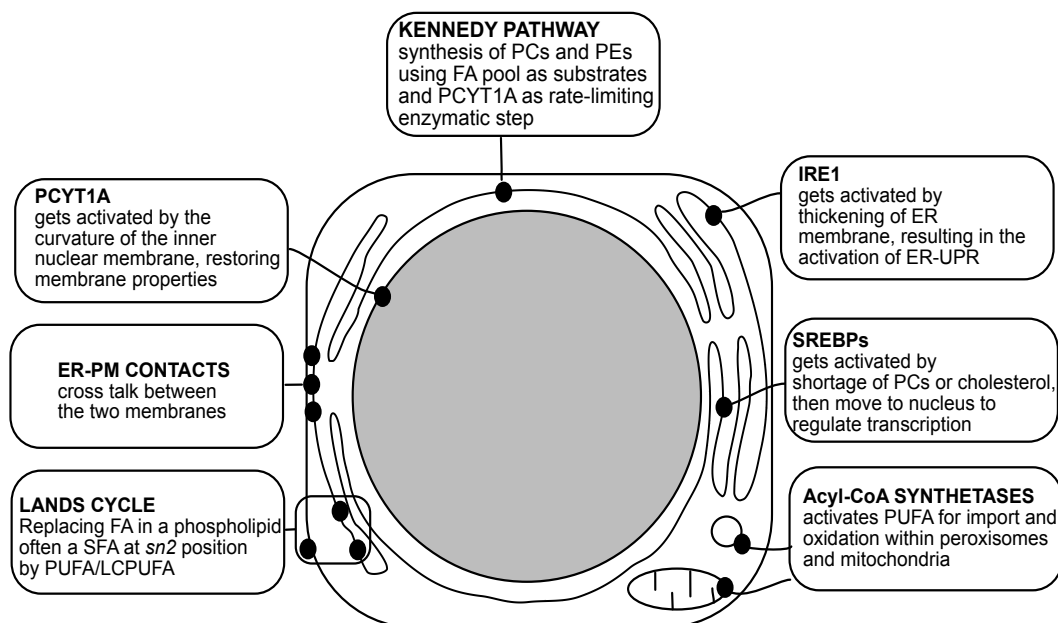

**Figure 3: Key membrane homeostasis processes.** Picture representing a cell with features relevant to membrane homeostasis (not including the AdipoRs).

## DesK sensing of membrane fluidity

DesK (histidine kinase) is the first and perhaps best understood sensor/regulator of membrane fluidity. The DesK and DesR (DNA binding response regulator) proteins were initially described as regulators of *des*, the desaturase gene in *B. subtilis*, during cold adaptation. It was found that at high temperatures (e.g. 37°C), DesK dephosphorylates DesR, which inactivates it, and at low temperatures (e.g. 25°C) DesK phosphorylates and thus activates DesR to induce the expression of *des* (Aguilar et al., 2001). The C terminal domain of dimeric DesK has autokinase activity, which autophosphorylates at H188, and the phosphate group is further transferred to D54 of DesR (Albanesi et al., 2004). Actual sensing of temperature and membrane fluidity have been attributed to the transmembrane domains of DesK whereby thickening of

the membrane, which typically accompanies rigidification, induces a conformational change that activates the kinase domain (Hunger et al., 2004).

### **MGA2 in yeast**

In yeast, the membrane sensitive activation of the class II sensor MGA2 is controlled by the dynamics of its transmembrane helix (TMH) which associates into homo-dimers (Covino et al., 2016). Dimers of MGA2 change their interface and are activated upon a change in the lipid saturation level and destabilizes the configuration with two tryptophans pointing toward the membrane environment. It is the high atom density within the phospholipid bilayer that is the true cause of the Mga2 conformational change that leads to its activation (Ballweg et al., 2020).

### **OPI1 sensing**

Yeast Opi1 is a soluble transcriptional repressor that controls the expression of genes involved in the production of phospholipids namely PC, PE, phosphatidylinositol and phosphatidylserine (Loewen et al., 2004). When Opi1 is active it is retained to ER membrane via interaction with specific lipid acyl chains. The group of Robert Ernst has studied the mechanism of Opi1 regulation using molecular modelling and in vitro binding assays. When the sensor is ON, the sensing amphipathic helices of OPI1 is folded and bound to membranes rich in negatively charged lipids. Bulky aromatic residues anchored to the hydrophobic core favor binding to curved, loosely packed membranes. When the sensor is in its OFF state, the amphipathic helices unfold and separate. Opi1 is one of the best example of a sense and response protein which monitors and adjust phospholipid composition (Hofbauer et al., 2018).

### **SREBP1/2 cholesterol and PC sensing**

In mammals there are two SREBPs namely SREBP1 and SREBP2. SREBP1 senses phospholipid composition and regulates both lipogenesis and cholesterol synthesis genes whereas SREBP2 senses cholesterol levels and regulates cholesterol synthesis genes (Horton et al., 2003). Silencing of both the genes in breast cancer cell lines have led to reduced expression of fatty acid de novo synthesis and desaturation genes. Accumulation of excesses SFA and activation of unfolded protein response (UPR), an ER response to membrane stress, was seen in these knockdown cells (Griffiths et al., 2013). SREB2 is synthesized and resides in the ER, having two transmembrane domains with its C and N termini in the cytoplasm. SREBP2 is associated with SCAP (SREBP cleavage-activating protein) and INSIG (insulin induced gene protein). During low levels of ER cholesterol, SREBP-SCAP complex is transported towards the Golgi and is retained by PAQR3 (Xu et al., 2015). SREBP is proteolytically processed by S1P and S2P (Site 1 protease and Site 2 protease) and releases a bHLH leucine zipper transcription factor domain that can enter into the nucleus and interact with MED15 to regulate the target genes of SREBPs. Regulation of SREBP1 is less understood. SREBP1 promotes fatty acid desaturation in response to PC depletion and this regulation is conserved from nematodes to mammals (Smulan et al., 2016). SREBP1 mRNA levels are also lowered by PUFAs. Altogether, it seems that SREBP1 is activated when there are shortages of PCs or PUFAs (Griffiths et al., 2013).

## **PCYT1A membrane packing defects**

PCs are the most abundant phospholipids in most cell membranes. The rate-limiting step in the Kennedy pathway (*de novo* synthesis of PCs and PEs) of PC synthesis is catalysed by PCYT1A, which contains a regulatory amphipathic helix that can associate with PC-containing bilayers. Once the levels of PCs are high enough to restore sufficient membrane packing, the PCYT1A amphipathic helix is repelled from the membrane, returning PCYT1A to its inactive state (Attard et al., 2000). When packing defects are present, PCYT1A translocates onto the inner nuclear membrane that is continuous with the ER and is activated; packing defects occur when there are shortage of PCs and results in curvature stress in yeast, fly and mammalian cells (Haider et al., 2018).

## **IRE1 as an ER membrane stress sensor**

The UPR is an ER stress response pathway triggered by the accumulation of unfolded protein in the ER. Such accumulation multimerizes IRE1, resulting in its activation. Activated IRE1 promotes alternative splicing of the transcription factor XBP1 which promotes transcription of ER response genes, which includes upregulation of several membrane synthesis pathways that lead to enlargement of the ER and thus expand its processing capacity. In *C. elegans*, IRE-1 dependent UPR activation is triggered by inhibition of the mevalonate pathway that produces prenyl lipids essential for the activities of several small GTPases important for membrane trafficking within the cell (Promlek et al., 2011; Shaffer et al., 2004; Sriburi et al., 2007). More recently, several studies have demonstrated that membrane rigidification can also act as a trigger for the activation of IRE1: rigidification of the ER membrane is accompanied by its thickening which in turns promotes clustering of IRE1 proteins that, because of their short TM domains, accumulate in small membrane compression domains and cross-phosphorylate each other, leading to their activation and stimulation of the UPR (Covino et al., 2016; Halbleib et al., 2017).

This concludes the general introduction of the scientific context for the present thesis. The following pages will describe some key methods then present the specific purpose and results of the experimental work as well as discuss the relevance of the results obtained.

# **Methods**

This thesis relied on two key methods to measure membrane fluidity in *C. elegans* and HEK293 cells. Because of their specialized nature, these methods will here be described in some details.

## **Fluorescence recovery after photobleaching (FRAP) in *C. elegans***

The transgenic strain QC114 carrying the *etEx2* extrachromosomal transgene which supports the expression of a membrane-associated prenylated GFP in intestinal cells (Morck et al., 2009). The *etEx2* transgene should be maintained by picking rollers and can be easily crossed into any mutant. Note that the transgene is in the form of extrachromosomal array and experiment are therefore done only on GFP positive cells.

Grow transgenic worms at 20 °C on 60 mm plates pre-seeded with approximately 200 µl of an overnight culture of *E. coli* OP50. Bleach the hermaphrodites and allow the eggs to hatch overnight in M9 buffer (Stiernagle, 2006). Transfer the synchronized L1 larvae to new plates containing 20 mM glucose or normal NGM plates. Prepare 20 mM glucose plates using filter sterilized (0.2 µm filter is used) and freshly prepared stock solution of 1 M glucose, which is added to cooled but still molten (~60 °C) NGM after autoclaving; seed these plates with *E. coli* OP50 as above.

After 16 h of incubation at 20 °C, mount the transgenic worms (rollers) on 2% agarose pads in a drop of 100 mM levamisole (dissolved in water; to paralyze the worms), and apply a cover glass. This step is critical to avoid worm twitching or movement. After overnight incubation, worms are at L2 stage, at this early stage the *etEx2* is expressed strongly and marks clearly intestinal plasma membranes. were photobleached over a circular region (7 pixels radius) using 10 iterations of the 488 nm laser with 100% laser power transmission. Images were collected at a 12-bit intensity resolution over 512×512 pixels (digital zoom 6X) using a pixel dwell time of ~1 µsec and were all acquired under identical settings. The fluorescence recovery of the bleached region was calculated as follows.

Firstly, all fluorescence values were adjusted to compensate for the slight and gradual bleaching caused by repetitive scanning and imaging. This was done by adjusting fluorescence values by the slope of the decreasing fluorescence in a reference non-photobleached region. In a next step, the lowest intensity value (immediately after bleaching) was identified and this value was subtracted from all intensities, thus setting the post-bleach fluorescence as zero. The average intensities of the five measurements that precede the bleaching were then determined, establishing a pre-bleach value; all intensities were normalized by dividing by that value. The average of the last five measurements (assumed to approximate the plateau of recovery) represent the maximum recovery and corresponds to the mobile fraction. The half-time of recovery is the time point where the fluorescence recovered to half of the maximum recovery. To obtain reliable FRAP measurements we approximately need 6-10 worms per experiment, which in practice often requires 15-20 measurement attempts because of slight movement of the worms. Important thing to consider here is worms that have been left too long on the agarose pads won't have the good signal required to perform the experiment. Worms mounted for more than 60 min should not be used (Devkota and Pilon, 2018).

### **Fluorescence recovery after photobleaching (FRAP) in HEK293 cells**

For FRAP in mammalian cells, HEK293 cells were seeded on µ-Dish 35<sup>mm,high</sup> Glass Bottom. These dishes allow us to perform high resolution microscopy. The day of experiment the cells should be at least 90% confluent. Prior to the experiment, the cells should be washed twice with PBS and then stain with BODIPY 500/510 C1, C12 (4,4-Difluoro-5-Methyl-4-Bora-3a,4a-Diaza-s-Indacene-3-Dodecanoic Acid) pre-dissolved in PBS at a concentration of 2 mg/ml and incubated for 10 min at 37 °C (Devkota et al., 2017). Take out the BODIPY media and add starvation media that does not contain any albumin and serum. Then proceed for microscopy.

FRAP images were acquired with an LSM880 confocal microscope equipped with a live cell chamber (set at 37 °C and 5% CO<sub>2</sub>) and ZEN software (Zeiss) with a 40X water

immersion objective. Cells were excited with a 488 nm laser and the emission between 493 and 589 nm recorded. Images were acquired with 16 bits image depth and 256 X 256 resolution using a pixel dwell of ~1.34 ms. At least ten ( $n > 10$ ) pre-bleaching images were collected and then the region of interest was beached with 50% of laser power. The recovery of fluorescence was traced for 25 s. Fluorescence recovery and Thalf were calculated as previously described (Devkota et al., 2017)

### **Laurdan dye measurement of membrane fluidity in HEK293 cells**

HEK293 cells were seeded on  $\mu$ -Dish 35<sup>mm,high</sup> Glass Bottom. These dishes allow us to perform high resolution microscopy. The day of experiment the cells should be atleast 90% confluent. Prior to the experiment, the cells should be washed twice with PBS and then stained with Laurdan dye (6-dodecanoyl-2-dimethylaminonaphthalene) (Thermo Fisher) pre-dissolved in starvation medium at a concentration of 10 mM and incubated for 45 minutes at 37°C. Then proceed for microscopy. Images were acquired with an LSM880 confocal microscope equipped with a live cell chamber (set at 37°C and 5% CO<sub>2</sub>) and ZEN software (Zeiss) with a 403 water immersion objective. Cells were excited with a 405 nm laser and the emission recorded between 410 and 461 nm (ordered phase) and between 470 and 530 nm (disordered phase). Pictures were acquired with 16 bits image depth and 1024 x 1024 resolution, using a pixel dwell of ~1.02 msec. Images were analyzed using ImageJ software (Schneider et al., 2012), following published guidelines (Owen et al., 2011).

The main limitations of the technique shoot from the resolution limit of the microscope. Excitation wavelength will be of the order 200-300 nm, depending on the dye and the objective used. As plasma membrane microdomains are postulated to be of the order of tens of nanometers, it is important to emphasize that the method described here cannot image individual domains. Instead, any resolution element (pixel) in the image will contain fluorescence signal originating from both disordered and ordered membrane regions. The GP value therefore gives an average measure of the membrane order in each diffraction-limited volume. The other major limitation is the simultaneous imaging of membrane order and the localization of specific proteins and lipids. This is difficult because of the broad emission spectrum of di-4-ANEPPDHQ and the need to switch between multiphoton and confocal imaging modes with Laurdan (Owen et al., 2011)

## **Results and Discussion**

### **Preview of the results and discussion**

We have previously shown that PAQR-2 is a regulator of membrane fluidity that acts together with its dedicated partner, the single-pass transmembrane protein IGLR-2 (Devkota et al., 2017; Svensk et al., 2016b). The *paqr-2* and *iglr-2* single mutants have similar phenotypes, including a characteristic tail tip defect, intolerance to cold and to dietary SFAs (Devkota et al., 2017; Svensk et al., 2016a). An SFA-rich diet can be conveniently achieved by cultivating *C. elegans* on plates containing 20 mM glucose, which is converted to SFAs by the dietary *E. coli* (Devkota et al., 2017). In order to

understand the mechanism of toxicity by dietary SFAs in *paqr-2* and *iglr-2* mutants we performed forward genetics screen in three different genetic backgrounds to isolate:

1. Novel mutants that suppress the lethality phenotypes of *paqr-2(tm3410)* on a diet rich in SFAs.
2. Novel mutants that suppress the lethality phenotypes of *iglr-2(et34)* on a diet rich in SFAs.
3. Novel mutants that can enhance the ability of *mdt-15(et14)* to suppress the SFA intolerance of the *paqr-2(tm3410)* mutant.

Over 100 000 mutagenized haploid genomes were screened leading to the isolation of 15 independent mutants. The screening procedure is depicted in Figure 4. These mutants were outcrossed to wild-type worms for several generations to remove unwanted mutations. Their entire genomes were then sequenced to help identify the mutations of interest, leading to the identification of novel alleles of the three genes that are the focus of this thesis, namely:

1. Eight novel alleles of *fld-1* (*membrane fluidity homeostasis-1*): Discussed in paper I.
2. One novel allele of *acs-13* (*acyl-CoA synthetase-13*): Discussed in Paper II.
3. One novel allele of *paqr-1* (*progesterin and adipoQ receptor-1*): Discussed in Paper III.

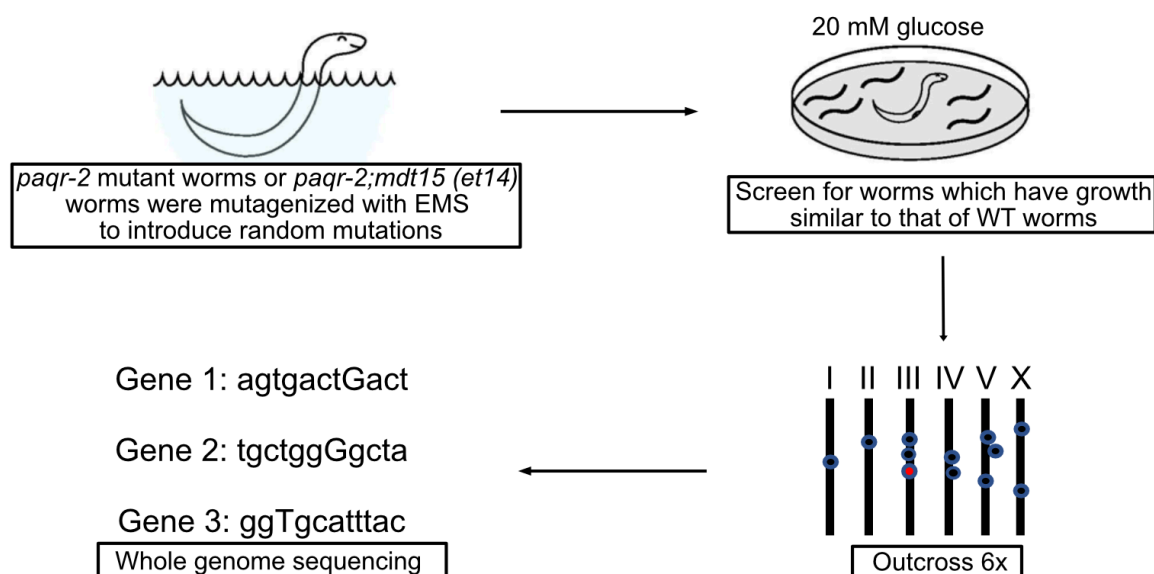

**Figure 4: Forward genetics screen.** EMS mutagenized *paqr-2* mutant worms or *paqr-2; mdt15 (et14)* worms were grown on NGM plates and the F2 generation was grown on 20 mM glucose plates. Now screened for worms that grow at normal WT and outcrossed for 6 times with N2 worms and sent for whole genome sequencing.

## PAPER I - Membrane fluidity is regulated by the *C. elegans* transmembrane protein FLD-1 and its human homologs TLCD1/2.

In this paper we extensively studied the previously uncharacterized *fld-1* gene and its mammalian homologs TLCD1 and TLCD2. The *fld-1(et48)* allele, carrying a mutation

in the splice donor site, was chosen as the reference allele and used in most of the experiments. The *fld-1* alleles isolated in the screen were *lof* mutations because introducing a wild type *fld-1* transgene abolished the growth of *paqr-2; fld-1(et48)* (or other *fld-1* alleles isolated in the screen) on glucose. These results were further confirmed by using a *lof fld-1(gk653147)* mutant obtained from the *C. elegans* one-million-mutation project (Thompson et al., 2013), which also suppressed the glucose intolerance phenotype of the *paqr-2* mutant. *C. elegans* carrying a translational GFP reporter (*Pfld-1::FLD-1::GFP*) revealed that the FLD-1 protein is expressed in the plasma membrane of all the cells throughout development and in adults. The expression of the wild type *fld-1* transgene specifically in hypodermis or in intestine also abolished the glucose intolerance phenotype of *paqr-2*. This result suggests that *fld-1* is functional in different tissues and is consistent with the previously published observation that membrane homeostasis is cell non-autonomous in *C. elegans* and relies on effective trafficking of lipids between different tissues (Bodhicharla et al., 2018).

The *fld-1* single mutant does not have any obvious phenotypes except for an increased activation of an oxidative stress response, scored using a *gst-4::GFP* reporter, when the worms were cultivated in the presence of LA, suggesting that there is a defect in LCPUFA management in the mutant. However, the novel *fld-1* alleles could suppress the previously described *paqr-2* mutant phenotypes, including SFA intolerance, cold intolerance and the withered tail tip defect (Devkota et al., 2017; Svensk et al., 2016b; Svensk et al., 2013). *fld-1(et48)* could also suppress the glucose intolerance of the *iglr-2(et34)* single mutant and *paqr-2(tm3410) iglr-2(et34)* double mutant. To elucidate the mechanism by which *fld-1(et48)* promotes membrane fluidity, we performed genetic interaction experiments with other *paqr-2* suppressors and also analysed the FA composition in these mutants. Mutation in *fld-1(48)* greatly enhanced the effect of the *mdt-15(et-14)*, *cept-1(et10)* (a choline/ethanolamine phosphotransferase) and *hacd-1(et12)* (a hydroxyl-acyl-CoA dehydrogenase) in suppressing SFA intolerance. These results tell us that *fld-1(et48)* works in a pathway separate from *mdt-15(et14)*. In vivo FRAP measurements confirmed that the *fld-1(et48)* allele restores membrane fluidity to *paqr-2(tm3410)* mutant worms cultivated in the presence of glucose (which as mentioned earlier is actually an SFA-rich diet given the conversion of glucose to SFAs by the dietary OP50) or PA. Expression of *fat-7::GFP* was enhanced by *mdt15(et14)* and *cept-1(et10)* but not by *fld-1(et48)*, again showing that *fld-1* acts in a separate pathway.

RNAi against the desaturases *fat-6* and *fat-7* abolished the ability of *fld-1(et48)* and *fld-1(et48); mdt15(et14)* to suppress of the glucose intolerance defect of *paqr-2(tm3410)* mutants. RNAi against *fat-5* only abolished the ability of *fld-1(et48)*, and not of *fld-1(et48); mdt15(et14)*, to suppress of the glucose intolerance defect of *paqr-2(tm3410)* mutants. These results indicate that *fld-1(et48)* does not act by promoting increased desaturase expression but that basal desaturase activity is important for its effect on membrane homeostasis. Analysis of PE composition in worms challenged with glucose shows that the *paqr-2* single mutant has an excess SFAs and reduced levels of LCPUFAs in the membranes and these defects are partially corrected by *mdt15(et14)* or *fld-1(et48)* mutations, and fully corrected by *mdt15(et14);fld-1(et48)*. The levels of MUFAs did not change in any combination. The results were exactly similar when PA was used to challenge the worms instead of glucose. It is important thing to note that

the lipidomics analysis was performed on whole worms and thus reflects global lipid composition rather than that of any specific membrane.

Speculatively, it is possible that the normal function of *fld-1* is either to limit the generation of LCPUFAs, to promote their turnover or inhibit their incorporation into phospholipids. In any case, mutations in *fld-1* could not only suppress *paqr-2* and *iglr-2* fluidity defects but also can suppress the phenotypes of the mutants where the production of PUFAs is abnormal. In order to test this, we used *fat-2* mutants, which are not able to convert 18:1 to 18:2 (Watts and Ristow, 2017), the primary precursors for LCPUFA. We found that the *fld-1(et48)* mutation indeed suppresses the growth defect of *fat-2* mutants both on normal plates and plates containing 20 mM glucose, and even in *paqr-2* mutant background. This means that the *fld-1* mutation causes either an increase in LCPUFA synthesis, reduces their turnover, or promotes the incorporation of any available LCPUFAs into phospholipids, resulting in increased membrane LCPUFA levels even though their production is reduced by mutations in *paqr-2*, *iglr-2* or *fat-2*. To support the above conclusion, we fed the *paqr-2; fld-1(et48)* double mutant worms with eicosapentaenoic acid (EPA; 20:5) and observed that *fld-1(et48)* can suppress the inability of the *paqr-2* mutant to accumulate EPA in their membranes.

TLCD1 and TLCD2 are the mammalian homologs of *fld-1*. The exact functions of TLCD1 and TLCD2 are not known, except for one study showing that TLCD1 (also known as calfacilitin) acts as a positive regulator of calcium channels (Papanayotou et al., 2013). The same study used immunoprecipitation of myc-tagged TLCD1 to show that it is localized to the plasma membrane. In order to study the molecular mechanism, we knocked down either of the genes by siRNA in human HEK293 cells. We found that TLCD1/2 knockdown was protective against the membrane rigidifying effects of 400  $\mu$ M PA (no effects were observed under basal, unchallenged conditions). There might be several hypotheses that could explain the protective effects of TLCD1 and TLCD2 knockdown, several of which could be tested experimentally. In particular, we found no difference in the rate of uptake of labelled PA in HEK293 cells treated with siRNA against TLCD1 and TLCD2. SFA content in the TAGs is also unaffected, and the expression levels of the desaturases SCD and FADS1, 2 and 3 are also not increased by TLCD1 and TLCD2 knockdown in HEK293 cells ruling out their regulation as a mechanism of fluidizing effect. Indeed, SCD expression was down regulated upon TLCD1/2 silencing, suggesting that this results in a decreased demand for their activity.

The mechanism of action of wild-type TLCD1/2 may be similar to that of FLD-1 in *C. elegans* i.e. limiting the production of LCPUFA containing phospholipids or act by promoting their turnover. To test this, we performed lipidomics analysis on TLCD1/2 knockdown cells and found out that there was a marked increase of 18:2, 18:3 and 20:5 and 20:6 LCPUFAs in the PEs of TLCD1 knockdown cells and of 18:2, 18:3 and 20:5 in the PCs of TLCD2 knockdown cells. One point to be noted is that there were no large differences in the FA composition of PCs and PEs under normal conditions, nor any changes in cholesterol content under basal or PA conditions or in the ceramide levels at basal condition. However, there was a dramatic increase of ceramide levels upon cultivation in PA, which may be attributed to PA levels being limiting for ceramide synthesis.



*de novo* PUFA synthesis is not needed for the TLCD2 effect on PUFA-containing phospholipids because cultivating the TLCD2 knockdown cells in the presence of exogenous EPA leads to its accumulation in PCs and PEs. TLCD2 does not regulate FA storage or LCPUFA uptake as there was no change in EPA storage or TAG storage in TAGs upon TLCD2 knockdown. EPA and decosahexaenoic acid (DHA) are very potent fluidizing lipids and we have shown that treatment with as little as 1  $\mu$ M EPA or DHA prevents membrane rigidification by 400  $\mu$ M PA. We also cultivated HEK293 cells in the presence of  $^{13}$ C-labeled LA (18:2) and monitored its incorporation and clearance rate in control cells or cells where either TLCD1 or TLCD2 knocked down and we observed that TLCD2 knockdown caused increased incorporation of LA in PCs and PEs within 6hrs of incubation, with pronounced effects by 24 hrs in the PEs of TLCD1 and TLCD2 knockdown cells. All these results indicate that the possible function of TLCD1 and TLCD2 is to limit the formation of LCPUFA-containing phospholipids.

Knockdown of TLCD2 protects against the membrane-rigidifying effects of PA when FADS2 desaturase is knocked down just as the *fld-1* mutation suppressed the effects of a *fat-2* mutation in *C. elegans*. This result adds more strength to the conclusion that TLCD2 acts independently from the desaturases. Also echoing our findings in worms, where *fld-1(et48)* suppresses *paqr-2* mutant phenotypes, we found that TLCD2 knockdown suppresses membrane rigidification caused by AdipoR2 knockdown in HEK293 cells.

## Discussion PAPER I

While most FAs in phospholipids are obtained from the diet, it is not quite true that the composition of cellular membranes reflects the composition of the dietary fats (Dancy et al., 2015). Indeed, it is difficult to increase SFA levels by increasing the SFA content of the diet. Therefore, there must be regulatory mechanisms that adjust the membrane composition to compensate for variations in dietary FA composition. Paper I, showed that *fld-1* mutations in *C. elegans* or knockdown of TLCD1 and TLCD2 in human cells result in an increase in LCPUFA-containing phospholipids. Wild-type *fld-1* and TLCD1/2 may therefore be involved in the regulation of membrane composition, possibly acting as limiters of LCPUFA levels, which could have a great impact on membrane properties since LCPUFAs are potent membrane fluidizers (Yang et al., 2011). Note that the LCPUFAs that are elevated in the *fld-1* mutant or by TLCD1/2 knockdown could have other functions besides influencing membrane fluidity, such as acting as precursors for signalling lipids (Watts, 2016). However, in our experiments, the important effect of *fld-1* is on membrane composition and fluidity because of the fact that *fld-1* mutations act as *paqr-2* and *iglr-2* suppressors and, similarly, siRNA against TLCD1/2 suppresses the membrane fluidity defects caused by siRNA against AdipoR2 and in the presence of exogenous palmitate.

The FLD-1 or TLCD1/2 proteins are characterized by the presence of a TLC domain and are distantly related to ER-localized ceramide synthases and to translocation associated membrane proteins (e.g. human TRAM1, TRAM2 and TRAM1L1) involved in membrane proteins synthesis in the ER (Winter and Ponting, 2002). However, FLD-1 and TLCD1/2 are localized to the plasma membrane and lack specific motifs such that they are neither ceramidase nor translocation associated proteins. An interesting possibility is that FLD-1 and TLCD1/2 influence substrate selection by phospholipases

or lysophospholipid acyltransferases that are part of the Lands cycle through which phospholipids are remodelled (Shindou et al., 2017).

When *fld-1* mutants are challenged with the LCPUFA LA, they exhibited an enhanced oxidative stress response. This result suggests a function for *C. elegans fld-1* in preventing such LCPUFA-derived oxidative stress. The ubiquitous plasma membrane expression of *C. elegans fld-1* suggests that it functions in all most every cell, though is not required under non-challenging conditions given the relative health of the mutant.

Paper I confirmed the importance of *paqr-2* and *iglr-2* in preventing dietary SFA-driven membrane rigidification and further suggests that there might be two separate “branches” (as depicted in Figure 5) downstream of *paqr-2/iglr-2*: “branch 1” that promotes the transcription of desaturases and illustrated by mutations such as *mdt-15(et14)* or *nhr-49(et8)*; and “branch 2” that promotes the incorporation of PUFAs into phospholipids and illustrated by the many *fld-1* alleles described in Paper I. Only by combining one mutation from each branch, for example *mdt-15(et14);fld-1(et48)*, does one achieve full suppression of all *paqr-2* mutant phenotypes. This is a concept that will be discussed again throughout Papers II and III. One final note: we have no evidence of a physical interaction between *paqr-2* and *fld-1*, and it is quite possible that *fld-1* is not an actual downstream component of the *paqr-2/iglr-2* pathway. This however would not detract from the usefulness of the *fld-1* alleles in revealing the existence of a “branch 2”, whatever its actual molecular nature.

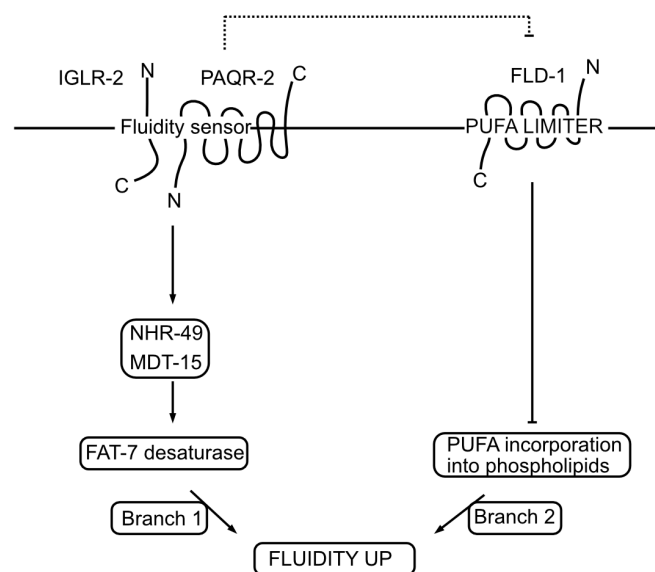

**Figure 5: Overview of the two branches of *paqr-2* pathway.** Branch 1 promotes transcription of the FAT-7 desaturase via *nhr-49/mdt-15* and branch 2 promotes incorporation of PUFAs into phospholipids.

## PAPER II - Evolutionarily conserved long-chain fatty acyl- CoA synthetases regulate membrane composition and fluidity

The novel *acs-13(et54)* allele was isolated in a screen for mutations that enhance the ability of *mdt-15(et14)* to suppress the SFA intolerance of the *paqr-2* null mutant. To this end, *paqr-2(tm3410) mdt-15(et14)* double mutants were mutagenized using ethyl methanesulfonate and their F2 progeny screened for the ability to grow into fertile adults within 72 hr when cultivated in the presence of 20 mM glucose (an expedient

way to provide a SFA-rich diet, as noted earlier). In total 50 000 haploid genomes were screened in this way, and six independent mutants were isolated. Four of the mutants were among the previously described *lof* alleles of the gene *fld-1* (Ruiz et al., 2018). The fifth mutation was identified as the *et54 lof* allele of *acs-13*, which encodes a *C. elegans* sequence homolog of the human long-chain fatty acid acyl-CoA synthetases ACSL1, ACSL5 and ACSL6.

The *acs-13(et54)* mutation causes a glycine-to-arginine amino acid substitution at positions 125 (G125R) in the N-terminal cytoplasmic domain. To confirm that this mutation is responsible for the *mdt-15(et14)* enhancer phenotype we used CRISPR/Cas9 to generate a separate line carrying exactly the same mutation and found that it too greatly improves the ability of *paqr-2(tm3410) mdt-15(et14)* double mutants to grow on 20 mM glucose as well as at 15°C. Additionally, *acs-13(ok2681)*, a deletion allele obtained from the *C. elegans* Genetic Centre, also enhances the ability of *mdt-15(et14)* to suppress the glucose and cold intolerance of *paqr-2* mutants. *acs-13(et54)* also acts as enhancer for *cept-1 (et10)*, which is another partial suppressor of *paqr-2(tm3410)* that acts by promoting transcription of the desaturase genes (Svensk et al., 2013). Interestingly, *acs-13(et54)* or *acs-13 (ok2861)* by themselves are not effective suppressors (i.e. they are very weak suppressors) of the *paqr-2* mutant phenotypes: they can only enhance the effects of partial *paqr-2* suppressor mutations such as *mdt-15(et14)* or *cept-1(et10)*. This suggests that *acs-13(et54)* requires the presence of elevated UFA levels in order to effectively compensate for the absence of a functional *paqr-2*.

There are three isoforms of ACS-13 and all of them are affected by the G125R mutation. Introducing a cDNA transgene of ACS-13 isoform “a” driven by the *acs-13* promoter restores glucose intolerance in *paqr-2(tm3410) mdt-15(et14); acs13(et54)* triple mutants, indicating that this isoform is functional. The same construct was modified to add GFP at the C-terminus end the resulting translational reporter was used to define the localization of the ACS-13 protein in vivo. We found that the GFP localizes specifically on the mitochondria of intestinal and hypodermal cells: the ACS-13 protein colocalizes with Mitotracker Deep red but not with the ER marker mCherry::SP12, and western blots on different cellular fractions revealed that ACS-13 is enriched in the mitochondrial fraction, and not in the cytosol or microsome fractions. *MDT-15* may act as a negative regulator of *acs-13* because we found, using qPCR, that *acs-13* expression was slightly decreased in the *mdt-15(et14)* background but remained unchanged in the *paqr-2* mutant background. An alternative explanation for this result is that some feedback regulation leads to decreased *acs-13* expression when UFA levels are elevated, as is the case in the *mdt-15(et14)* mutant.

There exists more than twenty acyl-CoA synthetases in *C. elegans*. We used *E. coli* strains from the Ahringer RNAi library (Kamath et al., 2003) to test whether inhibition of other acyl-CoA synthetases could enhance the ability of *mdt-15(et14)* to suppress the *paqr-2(tm3410)* mutant glucose intolerance and found that *acs-5*, *acs-15* and *acs-16* had this property. We further obtained the *lof acs-5(ok2668)* allele from the *C. elegans* Genetics Center and confirmed that it is indeed an enhancer of *mdt-15(et14)*. As was the case for *acs-13(et54)*, *acs-5(ok2668)* did not by itself act as a *paqr-2(tm3410)* suppressor and is not as potent as *acs-13(et54)*, which explains why it was not isolated in our forward genetics screen for *mdt-15(et14)* enhancers.

That *acs-13(et54)* acts as an enhancer of *mdt-15(et14)* suggests that these two mutations act in separate yet complementary pathways to suppress *paqr-2* mutant phenotypes. We hypothesized that *acs-13* doesn't act via transcriptional upregulation of fatty acid desaturase genes, which is the mechanism of action for *mdt-15(et14)*. This is indeed the case: the expression of the FAT-7::GFP reporter was increased in *mdt-15(et14)* mutants but remained unaffected in *acs-13(et54)*, and also in *paqr-2(tm3410);acs-13(et54)* (where expression was the same as in *paqr-2(tm3410)* single mutants). However, the ability of *acs-13(et54)* to act as enhancer of *mdt-15(et14)* does require the activity of desaturases since knockdown of the desaturases by RNAi significantly impairs the 15°C growth of *paqr-2 mdt-15(et14);acs-13(et54)* triple mutants, with *fat-6* and *fat-7* being the most important.

Analysis of the FA composition of PEs and PCs in worms showed that the single mutant *acs-13(et54)* has significantly increased levels of PUFAs in PEs when grown on nematode growth media (NGM) plates. The *mdt-15(et14)* single mutants had increased PUFAs in PEs when grown on NGM or plates containing 20 mM glucose. *paqr-2(tm3410)* mutants have low levels of PUFAs in PEs when cultivated on NGM and much lower levels when grown on 20 mM glucose (Devkota et al., 2017). Combining the *acs-13(et54)* and *mdt-15(et14)* mutations completely rescued the low PUFA content of the *paqr-2* mutants on both NGM and plates containing 20 mM glucose (Devkota et al., 2017; Svensk et al., 2016b). Additionally, we found that presence of *acs-13(et54)* by itself or in *paqr-2(tm3410)* mutant background caused a marked increase in specific LCPUFAs (e.g. 20:3, 20:4 and 20:5) on NGM plates. Similar findings were made with the less abundant PCs. These results suggest that *acs-13(et54)* acts as a *paqr-2(tm3410)* suppressor because it promotes an increased abundance of PUFA-containing phospholipids, which is one of the mechanisms to restore membrane fluidity.

In order to identify the mammalian homolog(s) of *acs-13*, we performed a sequence comparison and found out that ACSL1, ACSL5 and ACSL6 were most similar to the worm *acs-13*. By qPCR we found that ACSL1 is at least 20-fold more expressed than ACSL5 and ACSL6 in HEK293 cells. Our studies of *acs-13(et54)* in *C. elegans* revealed that this gene is important for regulating phospholipid composition in a way that ought to impact membrane fluidity. This was tested in HEK293 cells using the FRAP method. Under basal conditions silencing of ACSL-1, 5 and 6 has no effect on membrane fluidity. However, silencing ACSL1, but not ACSL5 or ACSL6, prevented membrane rigidification in HEK293 cells challenged with 400 µM PA. The Laurdan dye method (Ruiz et al., 2018) also confirmed the FRAP results. Our earlier findings showed that silencing AdipoR2 increases sensitivity of HEK293 cells to the rigidifying effects of PA (Bodhicharla et al., 2018; Devkota et al., 2017; Ruiz et al., 2018). Satisfyingly, silencing ACSL1 abolished the PA-induced membrane rigidification in AdipoR2 siRNA treated HEK293 cells. These results suggest that ACSL1 silencing acts as a suppressor of AdipoR2 silencing, just as the *acs-13(et54)* acts as *paqr-2(tm3410)* suppressor in *C. elegans*. It is interesting to note that ACSL1 expression did not change when silencing AdipoR2, which suggest that ACSL1 is not regulated by AdipoR2.

Lipidomics analysis in HEK293 cells showed that silencing of ACSL1 leads to a dramatic increase in PUFA-containing membrane phospholipids, with strong increase in 20:4, 22:5 and 22:6 in both PCs and PEs when the cells are challenged with PA.

This result is consistent with the findings in the *C. elegans asc-13(et48)* mutant. There was no change in PUFA levels within TAGs, or in PC/PE and cholesterol/PC ratios. All these results suggest that silencing ACSL1 in PA-challenged cells leads to a specific increase of PUFAs in phospholipids and there is no change in non-membrane lipids such as TAGs. As noted earlier, the subcellular localization of ACSL1 may vary between different cell types (Soupene and Kuypers, 2008). Using subcellular fraction and western blotting, we found that ACSL1 is strongly enriched in the mitochondria of HEK293 cells, which again is similar to the ACS-13 protein association with mitochondria observed in *C. elegans*. Some ACSL1 is associated with the ER in HEK293 cells though this appears to be a small minority of the protein. Association of ACSL1 with mitochondria is important for channelling the LCFAs into the organelle either for beta-oxidation or for mitochondrial membrane homeostasis. We found that ACSL1 siRNA treated cells had excess of palmitoylcarnitine in the mitochondria and a dramatic reduction in cardiolipins.

## Discussion PAPER II

Our findings support those of Zhu et al. who performed a CRISPR/Cas9 genome wide screen to identify modifiers of PA toxicity in human cells (Zhu et al., 2019). Their top hit for decreasing PA toxicity was ACSL3: mutating ACSL3 resulted in a decreased rate of SFA incorporation into phospholipids therefore helping to maintain membrane fluidity. Conversely, their top hit for increased PA toxicity was ACSL4: mutating ACSL4 decreases the rate of UFA incorporation into phospholipids, thus aggravating the membrane-rigidifying effects of PA.

Our work points towards a third ACSL that indirectly influences PA toxicity: mutating or inhibiting *acs-13* in *C. elegans* or ACSL1 in HEK293 cells reduces channelling of PUFAs into mitochondria, allowing elevated PUFA levels to be available for incorporation into phospholipids, which improves membrane fluidity. It is the subcellular localization of the ASCLs that mostly explains how they channel their acyl CoA products towards specific downstream pathways (Coleman, 2019). Our present work shows that both ACS-13 and ACSL1 are localized to mitochondrial membranes suggesting that this might be an evolutionary conserved site of action for this particular group of acyl-CoA synthetases. We found two major changes in the lipid composition when ACSL1 was silenced in HEK293 cells: 1) increased PUFA levels among PCs and PEs, which make up the bulk of the membranes 2) changes in the levels of cardiolipins and palmitoylcarnitine which are mitochondria-specific lipid classes. Both these findings suggest that absence of ACSL1 alters the import of LCFAs into mitochondria.

The present results allow us to re-evaluate the epistatic interactions important for membrane homeostasis in *C. elegans*. The PAQR-2/IGLR-2 complex is required for the tolerance to dietary SFAs and cold adaptation in *C. elegans* (Devkota et al., 2017; Svensk et al., 2016b; Svensk et al., 2013; Svensson et al., 2011). Over the years our group has identified several *paqr-2(tm3410)* suppressors and they fall into two broad classes, as shown in Figure 6. The first class are mutations that promote the production of UFAs, such as the *gof* mutations in *mdt-15* and *nhr-49* that act as transcriptional activator for the  $\Delta 9$  desaturases, or *lof* mutations in enzymes of PC synthesis pathway such as *pcyt-1* or *cept-1*, that result in *sbp-1* activation and hence also increased transcription of  $\Delta 9$  desaturases. The second class of *paqr-2(tm3410)* suppressors are

mutations that increase the incorporation rate of LCPUFAs into phospholipids, such as *lof* mutations in *fld-1* (Ruiz et al., 2018), and *lof* mutations in *acs-13*, described in the present Paper II. Individual suppressor mutations from either class are not alone sufficient to fully suppress the *paqr-2(tm3410)* SFA intolerance phenotype. However, combining suppressor mutants from both classes does provide excellent *paqr-2(tm3410)* suppression.

In conclusion, we showed that suppressing the activity of ACS-13 in *C. elegans* or of its homolog ACSL1 in HEK293 cells prevent SFA-induced membrane rigidification and lipotoxicity by increasing the abundance of LCPUFA-containing phospholipids.

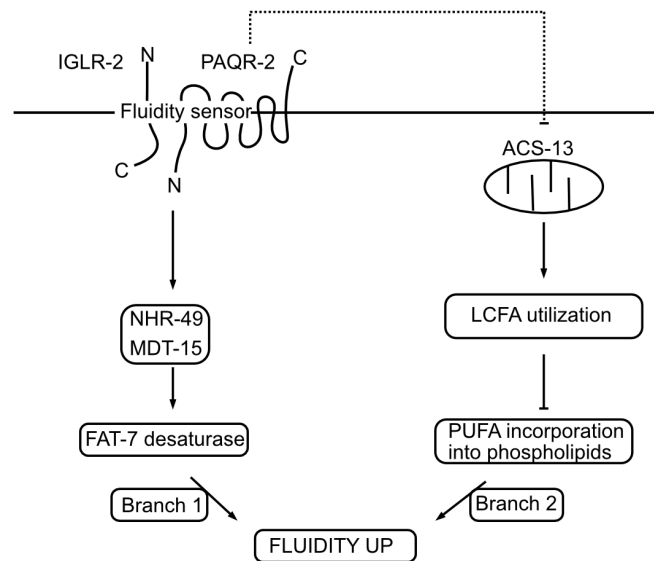

**Figure 6: Two separate fluidity promoting branches of PAQR-2 signalling.** Branch 1 promotes desaturase transcription while the branch 2 regulates incorporation of PUFAs into phospholipids.

### PAPER III- Leveraging a gain-of-function allele of *C. elegans* PAQR-1 to elucidate membrane homeostasis by PAQR proteins

The *paqr-1(et52)* allele was isolated from the screen described in Paper II. The *paqr-1(et52)* mutation causes a R109C amino acid substitution about halfway within the cytoplasmic N-terminal domain, which is quite divergent compared to that of PAQR-2 (the amino acid sequences of the PAQR-1 and PAQR-2 proteins are highly conserved throughout their 7TM domains but not in their N-terminal domain). Western blots against HA-tagged proteins expressed from CRISPR/Cas9 modified endogenous wild-type *paqr-1* or *paqr-1(et52)* loci showed that they are expressed at similar levels throughout development or when cultivated at different temperatures. By comparison, PAQR-2 expression is slightly higher in adults and increases with temperature. Localization of GFP translational reporters showed expression of PAQR-1(+) and PAQR-1(R109C) in several tissues, including gonad sheath cells, where the PAQR-2 protein is predominantly expressed. In spite of the unchanged expression and localization, *paqr-1(et52)* is clearly a *gof* mutation because providing it as a multicopy transgene in *paqr-2* mutant background, where the endogenous *paqr-1* is wild-type, efficiently suppresses the SFA intolerance, cold intolerance and tail tip defect. Conversely, providing wild-type *paqr-1* as a multicopy transgene could only suppress

the cold intolerance phenotype and partially suppressed the tail tip defect but does not suppress at all the intolerance to dietary SFAs.

An initial hypothesis to explain the *gof* properties of the novel *paqr-1* allele was that the R109C amino substitution could promote dimerization via disulfide bridges involving the cysteine. This is however not the case since substituting arginine at position 109 with the neutral amino acid alanine also suppresses cold intolerance, SFA intolerance and tail tip defects of the *paqr-2* mutant.

The *paqr-1(et52)* mutation suppresses all *paqr-2* defects tested so far, including the lipid composition defects. As mentioned earlier, lipidomics analysis of *paqr-2* mutants showed that they contain an excess of SFAs accompanied by a depletion of MUFAs/PUFAs in PEs. This lipid composition defect is abolished in *paqr-1(et52);paqr-2(tm3410)* double mutants. The same is also true of the membrane rigidification phenotype, which are abolished as measured using FRAP when *paqr-1(et52);paqr-2(tm3410)* double mutants are cultivated on glucose or PA. Note that *paqr-1(et52)* had no effect on the membrane fluidity of *paqr-2* mutants on normal plates or as a single mutant on normal plates or plates containing glucose. These results suggest that *paqr-1(et52)* acts as a complete functional replacement for *paqr-2* and that it has no adverse effects under the conditions tested.

The *lof paqr-1(tm3262)* allele had no *paqr-2* suppressor effect or indeed worsened *paqr-2* mutant phenotypes such as poor growth on both normal plates and plates with 20 mM glucose, 15°C intolerance, PE composition (even higher SFA levels than the single *paqr-2* mutant) and defects in pharyngeal pumping rate, brood size, life span, defecation rate and locomotion rate. This indicates some functional redundancy between the *paqr-1* and *paqr-2* genes. Our previous work showed that PAQR-2 and IGLR-2 potentially act as together as a fluidity sensor that likely signal through the nuclear hormone receptor *nhr-49* and/or *sbp-1* and *mdt-15* to promote the expression of  $\Delta 9$  desaturases (Svensk et al., 2016b; Svensk et al., 2013). Using RNAi, we found that *mdt-15*, *sbp-1* and *fat-5/-6/-7* desaturases are all required for the maximum activity of *paqr-1(et52)*. These results suggest that *paqr-1(et52)* is a version of *paqr-1* that acts in the same pathway as *paqr-2*.

Epistatic interaction studies were also carried out to try and further elucidate the nature of the *paqr-1/-2* pathway. Introducing *paqr-1(et52)* into *paqr-2;nhr-49* double *lof* mutants suppresses their synthetic lethality and tail tip defect but does not suppresses the glucose intolerance nor the cold intolerance. These results suggest that *nhr-49* is an essential *paqr-2* and *paqr-1(et52)* downstream target for SFA tolerance but that it also has other functions as well. In a separate series of experiments, we found that the *paqr-2;sbp-1* double mutant is sterile, and we were unable to generate a *paqr-2;sbp-1;paqr-1(et52)* triple mutant. This suggests that *paqr-1(et52)* cannot completely replace all *sbp-1* independent functions of *paqr-2*.

*paqr-2* is totally dependent on the presence of a functional *iglr-2* for its activity. *paqr-1(et52)* was unable to suppress the glucose intolerance of *iglr-2(et34)* mutant, though it suppressed its intolerance to cold. However, we found that *paqr-1(et52)* was able to suppress both glucose and cold intolerance in the *paqr-1(et52);paqr-2;iglr-2* triple mutant, as well as its tail tip defect. These results suggest that the presence of *paqr-2* inhibits *paqr-1(et52)* when *iglr-2* is absent. Hypothetically, the PAQR-2 protein may

compete with PAQR-1(R109C) for a downstream factor only when IGLR-2 is absent. Alternatively, it may be that PAQR-2 can interact with PAQR-1(R109C) and inhibit its function when IGLR-2 is absent. In either case it is clear that *iglr-2* gene is not required for the ability of *paqr-1(et52)* to rescue the *paqr-2* null mutant.

As pointed out earlier, the *paqr-1(et52)* allele corresponds to a R109C amino acid substitution in the N-terminal cytoplasmic domain that is divergent between PAQR-1 and PAQR-2. To better understand how PAQR-1 and PAQR-2 are regulated, we proceeded to swap the domains between the two proteins and added an HA tag at the N-terminus of the resulting chimeric proteins, which were all expressed from the *paqr-2* promoter to facilitate direct comparisons. The domains were swapped as shown in the Figure 7 and two independent lines were generated for each construct; their expression was confirmed using western blots against the HA tags. The constructs were then tested for their ability to rescue three defects of the *paqr-2* single and *paqr-2; iglr-2* double mutants, namely growth arrest at 15°, growth arrest on 20 mM glucose and the tail tip defect. The full length PAQR-1(R109C) protein, but not wild-type full length PAQR-1, rescued growth of *paqr-2* single mutant and *paqr-2; iglr-2* double mutant at 15°C and on glucose, as well as the tail tip morphology. Incidentally, this result confirms that adding HA tag at the N-terminus does not impair function or expression of PAQR-1(R109C). A chimeric protein composed of the N-terminal cytoplasmic domain of PAQR-1(R109C) and the transmembrane domains of PAQR-2, was able to rescue the growth at 15°C of the single *paqr-2* mutant but not that of the *paqr-2; iglr-2* double mutant. There was also no rescue observed on glucose plates nor of the tail tip defect. These results indicate that the transmembrane domains of PAQR-2 dictate the requirement for the presence of IGLR-2. Finally, swapping the short extracellular C-terminus domain of the PAQR-2 protein with that of PAQR-1(R109C) resulted in a small reduction in the ability to rescue the growth of *paqr-2* single mutants or *paqr-2; iglr-2* double mutants at 15°C or on glucose as well as tail tip phenotype.

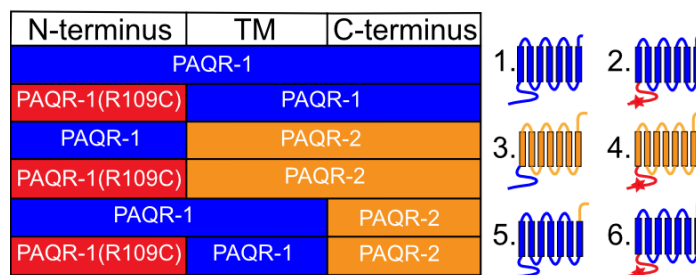

**Figure 7: Domain swapping strategy.** Cartoon representation of constructs used for swapping the domains between PAQR-1, PAQR-1(R109C) and PAQR-2 proteins

That overexpression of *paqr-1* can suppress *paqr-2* mutant phenotypes suggests that it acts either alone or via an interaction partner that is not limiting for PAQR-1 protein activity. It is was therefore interesting to test whether this relationship is conserved between human AdipoR1 and AdipoR2. For this purpose, we turned to AdipoR1 and AdipoR2 transfections in HEK293 cells. We found that overexpression of either AdipoR1 or AdipoR2 in HEK293 cells is sufficient to prevent membrane rigidification in HEK293 cells challenged with 400 μM PA. Finally, we found that overexpression of AdipoR1 prevents membrane rigidification by 200 μM PA in the cells where AdipoR2 has been silenced.



## Discussion PAPER III

The present work sheds new light on the roles of major protein domains in PAQR-1 and PAQR-2. In particular, we found that PAQR-1(R109C) and PAQR-2 signal through the same downstream effectors and can carry out very similar roles in membrane homeostasis. An interesting hypothesis is that the large N terminal domain has a regulatory function, for example acting as a gate blocking access to the cytoplasm-facing cavity where the hydrolytic site is located (as shown in Figure 8). This suggestion was previously made for the AdipoRs: while the published crystal structures of the AdipoRs does not include the complete N terminal domain, the short portion that was included did seem to obstruct the access to the cytoplasm-facing cavity, which prompted the authors to suggest that a much larger opening at helices III-VII would be uncovered on the cytoplasmic side, if the N-terminal region is displaced (Tanabe et al., 2015a). This type of regulation is similar to the “ball and chain mechanism” where the cytoplasmic domain acts as a ball attached by a flexible motif (the chains) and that can block access to a channel or cavity (Aldrich, 2001; Zhou et al., 2001). Hypothesizing further, the PAQR-1(R109C) or PAQR-1(R109A) mutations may displace the regulatory N terminal domain and thus cause a more frequent substrate access to the active site, and thus act as *gof* mutations. These substitutions in PAQR-1 might have important structural consequences, for example disrupting the interactions important for the proposed ball and chain mechanism.

Our finding that overexpression of AdipoR1 or AdipoR2 is sufficient to protect HEK293 cells from PA induced rigidification replicates those of Kupchak et al. who showed that AdipoR1 expression in yeast support its activity and mimic that of a yeast homolog (Kupchak et al., 2007), and of Holland et al. who showed that overexpression of AdipoR1 and AdipoR2 in liver leads to their increased activity, as measured by ceramidase activity in extracts (Holland et al., 2017). PAQR-1 and human AdipoR1 therefore seem to act in a dose-dependent manner, which suggests that they may have intrinsic basal activity that is not strictly regulated by the membrane environment. If this is true, then one would expect tissues require high PUFA levels or very fluid membranes to express higher levels of either AdipoR1 or AdipoR2. This seems to be the case for the PUFA-rich retina cells: the mouse and human retina has exceptionally high levels of AdipoR1 expression and the retina shows a severe depletion of membrane UFAs associated with retinitis pigmentosa (Sluch et al., 2018; Xu et al., 2016; Zhang et al., 2016).

Finally, the domain swapping experiments suggest that IGLR-2 and PAQR-2 interact primarily via their transmembrane domains and that an important consequence of this interaction may occurs at the level of their cytoplasmic domains. Quite speculatively, docking of IGLR-2 onto PAQR-2 via the transmembrane domains could allow the cytoplasmic domain of IGLR-2 to cause a conformational change within the cytoplasmic domain of PAQR-2 that results in its activation.

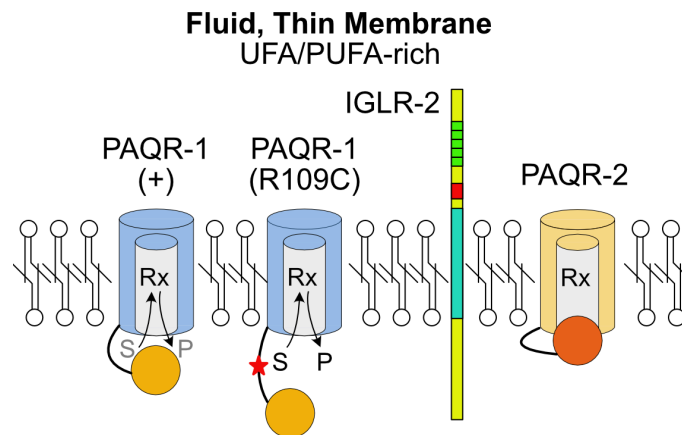

**Figure 8: Model of PAQR-1/2 regulation.** Proposed hypothesis in which the large N-terminal domain (orange/red circles) has a regulatory function by blocking access to the cytoplasm-facing cavity where the hydrolytic site (Rx) is located resulting in small rate of conversion of substrate (S) into product (P). The R109C mutation causes a conformational change in the cytoplasmic regulatory domain, providing greater access to the catalytic site, which results in more substrates being converted to signaling products.

## Future Perspectives

Complete genetic suppression of *paqr-2* mutant phenotypes is achieved only when combining a mutation that promotes fatty acid desaturase upregulation (e.g. *nhr-49* or *mdt-15* *gof* alleles) with a second mutation that promotes incorporation of PUFAs in membrane phospholipids (e.g. *fld-1* or *acs-13* *lof* alleles). This suggests that there are two downstream branches in the PAQR-2 pathway. One future line of investigation concerns defining the nature of the first branch of this pathway, i.e. the signal by which desaturase transcription is stimulation when PAQR-2 is active. A zinc ion is bound within the 7TM domain in the structures of AdipoR1/2, the PAQR-2 human homologs (Tanabe et al., 2015a) where it is coordinated by three His residues: specifically, His 202 in helix II and His 348 and His 352 in helix VII of AdipoR2. Furthermore, a water molecule is observed between the zinc ion and the side-chain carboxyl group of Asp219 in helix III of AdipoR2. The three His and Asp residues are strictly conserved in the homologues from mammals to bacteria. It will be interesting to mutate these conserved amino acids within the hydrolytic site of the PAQR-2 protein encoded by the rescue construct then check if it can still rescue the *paqr-2* mutant phenotypes. In particular, it would be interesting to test whether such a construct would effectively suppress the SFA intolerance of *paqr-2* mutants only when a “branch 1” mutation (e.g. *nhr-49* or *mdt-15* *gof* allele) is provided. Such a result would indicate that “branch 2” remains functional in the mutated construct and that it is “branch 1”, i.e. the signal to induce desaturase expression, that relies on the hydrolase activity.

A second line of investigation concerns defining the true nature of the second branch of the PAQR-2 pathway, i.e. “promotion of PUFA incorporation into phospholipids”. One powerful approach could be the use of co-immunoprecipitation (co-IP) to identify interaction partners. The available PAQR-2 antibodies are not robust, and so the best approach would be to modify the endogenous locus of PAQR-2 with a tag and perform IP experiments using tag-specific antibodies. Given that our findings regarding genetic

interactions are also conserved with AdipoR2 in mammalian cells, it will be logical to test whether the pull down of proteins are common between PAQR-2 and AdipoR2.

Genetic interactions studies, i.e. the fact that *lof* mutation in *fld-1* suppress *paqr-2* mutant phenotypes, suggest the possibility that PAQR-2 regulates FLD-1. There is however no biochemical evidence to actually show that a physical interaction exists between the two proteins. It would be good if we can perform Co-IP experiments between PAQR-2 and FLD-1 to actually see if they interact or not and how *paqr-2* regulates *fld-1*. The mechanism of how FLD-1 limit incorporation of PUFAs into phospholipids in the cellular membranes is also not known. One possible mechanism is via regulation of the Land's cycle through which phospholipids are actively remodeled by FA exchange and which effectively influences membrane composition and properties. The presence of several membrane-bound acyl transferases in *C. elegans* suggest a promising avenue for genetic interaction studies (Lee et al., 2008).

ACSL1 can localize to the plasma membrane, ER, mitochondria, nucleus, peroxisomes, lipid droplets and GLUT-4 vesicles (Lewin et al., 2001). We have already shown that ACSL1/ACS-13 is localized to mitochondria where we speculated that LCFAs are channeled for utilization (i.e. incorporated into mitochondrial membranes) or degradation (Ruiz et al., 2019a). Further in future, it will be interesting to specifically measure the rate of beta-oxidation of *acs-13* mutants in mitochondria. Additionally, previous studies have shown that peroxisomes are the sites where ACSLs channel LCFAs for degradation (Grevengoed et al., 2014), and are transported out of the peroxisome as short to medium-chain acyl-carnitines and to be completely oxidized in the mitochondria; it will therefore be interesting to test if ACS-13 also plays a role in peroxisomal oxidation of LCFAs

We have shown that the PAQR-1(R109C) mutation makes the protein to act in a dose-dependent manner and able to functionally replace PAQR-2. It would be interesting to explore the structural consequences of this mutation using molecular modelling as an approach to further explore the "ball and chain" hypothesis.

Finally, in clinical contexts, targeting of specific acyl-CoA synthetases, such as ACSL1, with small-molecule inhibitors open new therapeutic avenues against lipotoxicity such as dyslipidemia or liver steatosis (Ruiz et al., 2019a). Inhibitors of TLCD1/2 may also have therapeutic potential in instances of lipotoxicity and excess membrane rigidity, which is a feature of the diabetic condition (Pilon, 2016).

# Acknowledgements

First of all, I would like to thank my supervisor, **Marc**, for letting me to do my PhD in his group. I would like to express my special appreciation for your guidance, motivation, sharing your immense knowledge and always allowing to do good science. This wouldn't have been possible without your support both personally and professionally.

**Ranjan**, thank you very much for all the help especially for sharing your knowledge on various research topics. Learnt a lot from you!!! Good luck with your defense!!! **Mario**, thank you very much for sharing your knowledge and experience about working with mammalian cells and I am sure it will help me in future.

**Xin**, thanks for your support. You were always there when ever I needed anything. **Andreas**, thanks man for those wonderful days at CMB, had wonderful discussions and ping pong games. Thanks for your suggestions and help during the crisis time.

I would like to thank all the principal investigators at the department **Per, Peter, Ann, Julie, Markus, Jeanette**, for creating such a nice working environment and for their unlimited support. Many thanks to all the present and past members of CMB: **Chao, Ali, Azadeh, Sansan, Johanna, Josefina, Rakesh, Emma, Jason, Catarina, Sanjiv**. Technical staff: **Bruno, Lars, Leif, Peter** and **Valida** thanks for always being very helpful.

**Dad** and **Mom**, words are not enough to thank you for always loving me for who I am and always welcoming me with open arms. Will always remember the sacrifice that you made in shaping my carrier. Thanks to my **brother, sister-in-law, father-in-law** and **mother-in-law** for their unconditional support.

Last but not least I would like to thank my wife **Soujanya** for her cooperation in every aspect of life. **Niharika** probably you are the best thing ever happened in my life. You made my life bright and meaningful.

## References

- Aguilar, P.S., Hernandez-Arriaga, A.M., Cybulski, L.E., Erazo, A.C., and de Mendoza, D. (2001). Molecular basis of thermosensing: a two-component signal transduction thermometer in *Bacillus subtilis*. *EMBO J* 20, 1681-1691.
- Albanesi, D., Mansilla, M.C., and de Mendoza, D. (2004). The membrane fluidity sensor DesK of *Bacillus subtilis* controls the signal decay of its cognate response regulator. *J Bacteriol* 186, 2655-2663.
- Aldrich, R.W. (2001). Fifty years of inactivation. *Nature* 411, 643-644.
- Attard, G.S., Templer, R.H., Smith, W.S., Hunt, A.N., and Jackowski, S. (2000). Modulation of CTP:phosphocholine cytidyltransferase by membrane curvature elastic stress. *Proc Natl Acad Sci U S A* 97, 9032-9036.
- Ballweg, S., Sezgin, E., Doktorova, M., Covino, R., Reinhard, J., Wunnicke, D., Hanelt, I., Levental, I., Hummer, G., and Ernst, R. (2020). Regulation of lipid saturation without sensing membrane fluidity. *Nat Commun* 11, 756.
- Bell, R.M., Ballas, L.M., and Coleman, R.A. (1981). Lipid topogenesis. *J Lipid Res* 22, 391-403.
- Bjursell, M., Ahnmark, A., Bohlooly, Y.M., William-Olsson, L., Rhedin, M., Peng, X.R., Ploj, K., Gerdin, A.K., Arnerup, G., Elmgren, A., et al. (2007). Opposing effects of adiponectin receptors 1 and 2 on energy metabolism. *Diabetes* 56, 583-593.
- Black, P.N., and DiRusso, C.C. (2003). Transmembrane movement of exogenous long-chain fatty acids: proteins, enzymes, and vectorial esterification. *Microbiol Mol Biol Rev* 67, 454-472, table of contents.
- Bodhicharla, R., Devkota, R., Ruiz, M., and Pilon, M. (2018). Membrane Fluidity Is Regulated Cell Nonautonomously by *Caenorhabditis elegans* PAQR-2 and Its Mammalian Homolog AdipoR2. *Genetics* 210, 189-201.
- Boumann, H.A., Gubbens, J., Koorengevel, M.C., Oh, C.S., Martin, C.E., Heck, A.J., Patton-Vogt, J., Henry, S.A., de Kruijff, B., and de Kroon, A.I. (2006). Depletion of phosphatidylcholine in yeast induces shortening and increased saturation of the lipid acyl chains: evidence for regulation of intrinsic membrane curvature in a eukaryote. *Mol Biol Cell* 17, 1006-1017.
- Brenner, S. (1974). The genetics of *Caenorhabditis elegans*. *Genetics* 77, 71-94.
- Brock, T.J., Browse, J., and Watts, J.L. (2006). Genetic regulation of unsaturated fatty acid composition in *C. elegans*. *PLoS Genet* 2, e108.
- Brock, T.J., Browse, J., and Watts, J.L. (2007). Fatty acid desaturation and the regulation of adiposity in *Caenorhabditis elegans*. *Genetics* 176, 865-875.
- Brooks, K.K., Liang, B., and Watts, J.L. (2009). The influence of bacterial diet on fat storage in *C. elegans*. *PLoS One* 4, e7545.

Cases, S., Stone, S.J., Zhou, P., Yen, E., Tow, B., Lardizabal, K.D., Voelker, T., and Farese, R.V., Jr. (2001). Cloning of DGAT2, a second mammalian diacylglycerol acyltransferase, and related family members. *J Biol Chem* 276, 38870-38876.

Coleman, R.A. (2019). It takes a village: channeling fatty acid metabolism and triacylglycerol formation via protein interactomes. *J Lipid Res* 60, 490-497.

Corsi, A.K. (2006). A biochemist's guide to *Caenorhabditis elegans*. *Anal Biochem* 359, 1-17.

Covino, R., Ballweg, S., Stordeur, C., Michaelis, J.B., Puth, K., Wernig, F., Bahrami, A., Ernst, A.M., Hummer, G., and Ernst, R. (2016). A Eukaryotic Sensor for Membrane Lipid Saturation. *Mol Cell* 63, 49-59.

Covino, R., Hummer, G., and Ernst, R. (2018). Integrated Functions of Membrane Property Sensors and a Hidden Side of the Unfolded Protein Response. *Mol Cell* 71, 458-467.

Dancy, B.C., Chen, S.W., Drechsler, R., Gafken, P.R., and Olsen, C.P. (2015). 13C- and 15N-Labeling Strategies Combined with Mass Spectrometry Comprehensively Quantify Phospholipid Dynamics in *C. elegans*. *PLoS One* 10, e0141850.

de Mendoza, D., and Pilon, M. (2019). Control of membrane lipid homeostasis by lipid-bilayer associated sensors: A mechanism conserved from bacteria to humans. *Prog Lipid Res* 76, 100996.

Devkota, R., and Pilon, M. (2018). FRAP: A Powerful Method to Evaluate Membrane Fluidity in *Caenorhabditis elegans*. *Bio-Protocol* 8.

Devkota, R., Svensk, E., Ruiz, M., Stahlman, M., Boren, J., and Pilon, M. (2017). The adiponectin receptor AdipoR2 and its *Caenorhabditis elegans* homolog PAQR-2 prevent membrane rigidification by exogenous saturated fatty acids. *PLoS Genet* 13, e1007004.

Durgan, D.J., Smith, J.K., Hotze, M.A., Egbejimi, O., Cuthbert, K.D., Zaha, V.G., Dyck, J.R., Abel, E.D., and Young, M.E. (2006). Distinct transcriptional regulation of long-chain acyl-CoA synthetase isoforms and cytosolic thioesterase 1 in the rodent heart by fatty acids and insulin. *Am J Physiol Heart Circ Physiol* 290, H2480-2497.

Ernst, R., Ejsing, C.S., and Antonny, B. (2016). Homeoviscous Adaptation and the Regulation of Membrane Lipids. *J Mol Biol* 428, 4776-4791.

Farrell, S.O., Fiol, C.J., Reddy, J.K., and Bieber, L.L. (1984). Properties of purified carnitine acyltransferases of mouse liver peroxisomes. *J Biol Chem* 259, 13089-13095.

Fruebis, J., Tsao, T.S., Javorschi, S., Ebbets-Reed, D., Erickson, M.R., Yen, F.T., Bihain, B.E., and Lodish, H.F. (2001). Proteolytic cleavage product of 30-kDa adipocyte complement-related protein increases fatty acid oxidation in muscle and causes weight loss in mice. *Proc Natl Acad Sci U S A* 98, 2005-2010.

Fullekrug, J., Eehalt, R., and Poppelreuther, M. (2012). Outlook: membrane junctions enable the metabolic trapping of fatty acids by intracellular acyl-CoA synthetases. *Front Physiol* 3, 401.

Grevengoed, T.J., Klett, E.L., and Coleman, R.A. (2014). Acyl-CoA metabolism and partitioning. *Annu Rev Nutr* 34, 1-30.

Griffiths, B., Lewis, C.A., Bensaad, K., Ros, S., Zhang, Q., Ferber, E.C., Konisti, S., Peck, B., Miess, H., East, P., et al. (2013). Sterol regulatory element binding protein-dependent regulation of lipid synthesis supports cell survival and tumor growth. *Cancer Metab* 1, 3.

Haider, A., Wei, Y.C., Lim, K., Barbosa, A.D., Liu, C.H., Weber, U., Mlodzik, M., Oras, K., Collier, S., Hussain, M.M., et al. (2018). PCYT1A Regulates Phosphatidylcholine Homeostasis from the Inner Nuclear Membrane in Response to Membrane Stored Curvature Elastic Stress. *Dev Cell* 45, 481-495 e488.

Halbleib, K., Pesek, K., Covino, R., Hofbauer, H.F., Wunnicke, D., Hanelt, I., Hummer, G., and Ernst, R. (2017). Activation of the Unfolded Protein Response by Lipid Bilayer Stress. *Mol Cell* 67, 673-684 e678.

Hanahan, D.J., Brockerhoff, H., and Barron, E.J. (1960). The site of attack of phospholipase (lecithinase) A on lecithin: a re-evaluation. Position of fatty acids on lecithins and triglycerides. *J Biol Chem* 235, 1917-1923.

Hazel, J.R. (1984). Effects of temperature on the structure and metabolism of cell membranes in fish. *Am J Physiol* 246, R460-470.

Hofbauer, H.F., Gecht, M., Fischer, S.C., Seybert, A., Frangakis, A.S., Stelzer, E.H.K., Covino, R., Hummer, G., and Ernst, R. (2018). The molecular recognition of phosphatidic acid by an amphipathic helix in Opi1. *J Cell Biol* 217, 3109-3126.

Holland, W.L., Miller, R.A., Wang, Z.V., Sun, K., Barth, B.M., Bui, H.H., Davis, K.E., Bikman, B.T., Halberg, N., Rutkowski, J.M., et al. (2011). Receptor-mediated activation of ceramidase activity initiates the pleiotropic actions of adiponectin. *Nat Med* 17, 55-63.

Holland, W.L., Xia, J.Y., Johnson, J.A., Sun, K., Pearson, M.J., Sharma, A.X., Quittner-Strom, E., Tippetts, T.S., Gordillo, R., and Scherer, P.E. (2017). Inducible overexpression of adiponectin receptors highlight the roles of adiponectin-induced ceramidase signaling in lipid and glucose homeostasis. *Mol Metab* 6, 267-275.

Horton, J.D., Shah, N.A., Warrington, J.A., Anderson, N.N., Park, S.W., Brown, M.S., and Goldstein, J.L. (2003). Combined analysis of oligonucleotide microarray data from transgenic and knockout mice identifies direct SREBP target genes. *Proc Natl Acad Sci U S A* 100, 12027-12032.

Hu, E., Liang, P., and Spiegelman, B.M. (1996). AdipoQ is a novel adipose-specific gene dysregulated in obesity. *J Biol Chem* 271, 10697-10703.

Hunger, K., Beckering, C.L., and Marahiel, M.A. (2004). Genetic evidence for the temperature-sensing ability of the membrane domain of the *Bacillus subtilis* histidine kinase DesK. *FEMS Microbiol Lett* *230*, 41-46.

Hunt, M.C., Siponen, M.I., and Alexson, S.E. (2012). The emerging role of acyl-CoA thioesterases and acyltransferases in regulating peroxisomal lipid metabolism. *Biochim Biophys Acta* *1822*, 1397-1410.

Kamath, R.S., Fraser, A.G., Dong, Y., Poulin, G., Durbin, R., Gotta, M., Kanapin, A., Le Bot, N., Moreno, S., Sohrmann, M., et al. (2003). Systematic functional analysis of the *Caenorhabditis elegans* genome using RNAi. *Nature* *421*, 231-237.

Kanter, J.E., and Bornfeldt, K.E. (2013). Inflammation and diabetes-accelerated atherosclerosis: myeloid cell mediators. *Trends Endocrinol Metab* *24*, 137-144.

Kanter, J.E., Kramer, F., Barnhart, S., Averill, M.M., Vivekanandan-Giri, A., Vickery, T., Li, L.O., Becker, L., Yuan, W., Chait, A., et al. (2012a). Diabetes promotes an inflammatory macrophage phenotype and atherosclerosis through acyl-CoA synthetase 1. *Proc Natl Acad Sci U S A* *109*, E715-724.

Kanter, J.E., Tang, C., Oram, J.F., and Bornfeldt, K.E. (2012b). Acyl-CoA synthetase 1 is required for oleate and linoleate mediated inhibition of cholesterol efflux through ATP-binding cassette transporter A1 in macrophages. *Biochim Biophys Acta* *1821*, 358-364.

Karpichev, I.V., Cornivelli, L., and Small, G.M. (2002). Multiple regulatory roles of a novel *Saccharomyces cerevisiae* protein, encoded by YOL002c, in lipid and phosphate metabolism. *J Biol Chem* *277*, 19609-19617.

Karpichev, I.V., and Small, G.M. (1998). Global regulatory functions of Oaf1p and Pip2p (Oaf2p), transcription factors that regulate genes encoding peroxisomal proteins in *Saccharomyces cerevisiae*. *Mol Cell Biol* *18*, 6560-6570.

Kniazeva, M., Crawford, Q.T., Seiber, M., Wang, C.Y., and Han, M. (2004). Monomethyl branched-chain fatty acids play an essential role in *Caenorhabditis elegans* development. *PLoS Biol* *2*, E257.

Kubota, N., Terauchi, Y., Yamauchi, T., Kubota, T., Moroi, M., Matsui, J., Eto, K., Yamashita, T., Kamon, J., Satoh, H., et al. (2002). Disruption of adiponectin causes insulin resistance and neointimal formation. *J Biol Chem* *277*, 25863-25866.

Kupchak, B.R., Garitaonandia, I., Villa, N.Y., Mullen, M.B., Weaver, M.G., Regalla, L.M., Kendall, E.A., and Lyons, T.J. (2007). Probing the mechanism of FET3 repression by Izh2p overexpression. *Biochim Biophys Acta* *1773*, 1124-1132.

Kwak, S.J., Hong, S.H., Bajracharya, R., Yang, S.Y., Lee, K.S., and Yu, K. (2013). *Drosophila* adiponectin receptor in insulin producing cells regulates glucose and lipid metabolism by controlling insulin secretion. *PLoS One* *8*, e68641.



- Lands, W.E. (2000). Stories about acyl chains. *Biochim Biophys Acta* 1483, 1-14.
- Laws, K.M., Sampson, L.L., and Drummond-Barbosa, D. (2015). Insulin-independent role of adiponectin receptor signaling in *Drosophila* germline stem cell maintenance. *Dev Biol* 399, 226-236.
- Lee, D., Jeong, D.E., Son, H.G., Yamaoka, Y., Kim, H., Seo, K., Khan, A.A., Roh, T.Y., Moon, D.W., Lee, Y., et al. (2015). SREBP and MDT-15 protect *C. elegans* from glucose-induced accelerated aging by preventing accumulation of saturated fat. *Genes Dev* 29, 2490-2503.
- Lee, H.C., Inoue, T., Imae, R., Kono, N., Shirae, S., Matsuda, S., Gengyo-Ando, K., Mitani, S., and Arai, H. (2008). *Caenorhabditis elegans* mboa-7, a member of the MBOAT family, is required for selective incorporation of polyunsaturated fatty acids into phosphatidylinositol. *Mol Biol Cell* 19, 1174-1184.
- Lee, K., Kerner, J., and Hoppel, C.L. (2011). Mitochondrial carnitine palmitoyltransferase 1a (CPT1a) is part of an outer membrane fatty acid transfer complex. *J Biol Chem* 286, 25655-25662.
- Lee, S.J., Murphy, C.T., and Kenyon, C. (2009). Glucose shortens the life span of *C. elegans* by downregulating DAF-16/FOXO activity and aquaporin gene expression. *Cell Metab* 10, 379-391.
- Lesa, G.M., Palfreyman, M., Hall, D.H., Clandinin, M.T., Rudolph, C., Jorgensen, E.M., and Schiavo, G. (2003). Long chain polyunsaturated fatty acids are required for efficient neurotransmission in *C. elegans*. *J Cell Sci* 116, 4965-4975.
- Lewin, T.M., Kim, J.H., Granger, D.A., Vance, J.E., and Coleman, R.A. (2001). Acyl-CoA synthetase isoforms 1, 4, and 5 are present in different subcellular membranes in rat liver and can be inhibited independently. *J Biol Chem* 276, 24674-24679.
- Li, L.O., Ellis, J.M., Paich, H.A., Wang, S., Gong, N., Altshuller, G., Thresher, R.J., Koves, T.R., Watkins, S.M., Muoio, D.M., et al. (2009). Liver-specific loss of long chain acyl-CoA synthetase-1 decreases triacylglycerol synthesis and beta-oxidation and alters phospholipid fatty acid composition. *J Biol Chem* 284, 27816-27826.
- Lindgren, A., Levin, M., Rodrigo Blomqvist, S., Wikstrom, J., Ahnmark, A., Mogensen, C., Bottcher, G., Bohlooly, Y.M., Boren, J., Gan, L.M., et al. (2013). Adiponectin receptor 2 deficiency results in reduced atherosclerosis in the brachiocephalic artery in apolipoprotein E deficient mice. *PLoS One* 8, e80330.
- Liu, Y., Michael, M.D., Kash, S., Bensch, W.R., Monia, B.P., Murray, S.F., Otto, K.A., Syed, S.K., Bhanot, S., Sloop, K.W., et al. (2007). Deficiency of adiponectin receptor 2 reduces diet-induced insulin resistance but promotes type 2 diabetes. *Endocrinology* 148, 683-692.

Loewen, C.J., Gaspar, M.L., Jesch, S.A., Delon, C., Ktistakis, N.T., Henry, S.A., and Levine, T.P. (2004). Phospholipid metabolism regulated by a transcription factor sensing phosphatidic acid. *Science* *304*, 1644-1647.

Lyons, T.J., Villa, N.Y., Regalla, L.M., Kupchak, B.R., Vagstad, A., and Eide, D.J. (2004). Metalloregulation of yeast membrane steroid receptor homologs. *Proc Natl Acad Sci U S A* *101*, 5506-5511.

Maeda, N., Shimomura, I., Kishida, K., Nishizawa, H., Matsuda, M., Nagaretani, H., Furuyama, N., Kondo, H., Takahashi, M., Arita, Y., et al. (2002). Diet-induced insulin resistance in mice lacking adiponectin/ACRP30. *Nat Med* *8*, 731-737.

Marr, A.G., and Ingraham, J.L. (1962). Effect of Temperature on the Composition of Fatty Acids in *Escherichia Coli*. *J Bacteriol* *84*, 1260-1267.

Mattiazzi Usaj, M., Prelec, M., Brloznic, M., Primo, C., Curk, T., Scancar, J., Yenush, L., and Petrovic, U. (2015). Yeast *Saccharomyces cerevisiae* adiponectin receptor homolog *Izh2* is involved in the regulation of zinc, phospholipid and pH homeostasis. *Metallomics* *7*, 1338-1351.

Matyash, V., Geier, C., Henske, A., Mukherjee, S., Hirsh, D., Thiele, C., Grant, B., Maxfield, F.R., and Kurzchalia, T.V. (2001). Distribution and transport of cholesterol in *Caenorhabditis elegans*. *Mol Biol Cell* *12*, 1725-1736.

Merris, M., Wadsworth, W.G., Khamrai, U., Bittman, R., Chitwood, D.J., and Lenard, J. (2003). Sterol effects and sites of sterol accumulation in *Caenorhabditis elegans*: developmental requirement for 4 $\alpha$ -methyl sterols. *J Lipid Res* *44*, 172-181.

Milger, K., Herrmann, T., Becker, C., Gotthardt, D., Zickwolf, J., Ehehalt, R., Watkins, P.A., Stremmel, W., and Fullekrug, J. (2006). Cellular uptake of fatty acids driven by the ER-localized acyl-CoA synthetase FATP4. *J Cell Sci* *119*, 4678-4688.

Mondoux, M.A., Love, D.C., Ghosh, S.K., Fukushige, T., Bond, M., Weerasinghe, G.R., Hanover, J.A., and Krause, M.W. (2011). O-linked-N-acetylglucosamine cycling and insulin signaling are required for the glucose stress response in *Caenorhabditis elegans*. *Genetics* *188*, 369-382.

Morck, C., Olsen, L., Kurth, C., Persson, A., Storm, N.J., Svensson, E., Jansson, J.O., Hellqvist, M., Enejder, A., Faergeman, N.J., et al. (2009). Statins inhibit protein lipidation and induce the unfolded protein response in the non-sterol producing nematode *Caenorhabditis elegans*. *Proc Natl Acad Sci U S A* *106*, 18285-18290.

Murray, P., Hayward, S.A., Govan, G.G., Gracey, A.Y., and Cossins, A.R. (2007). An explicit test of the phospholipid saturation hypothesis of acquired cold tolerance in *Caenorhabditis elegans*. *Proc Natl Acad Sci U S A* *104*, 5489-5494.

Napier, J.A., Hey, S.J., Lacey, D.J., and Shewry, P.R. (1998). Identification of a *Caenorhabditis elegans* Delta6-fatty-acid-desaturase by heterologous expression in *Saccharomyces cerevisiae*. *Biochem J* 330 ( Pt 2), 611-614.

Nawrocki, A.R., Rajala, M.W., Tomas, E., Pajvani, U.B., Saha, A.K., Trumbauer, M.E., Pang, Z., Chen, A.S., Ruderman, N.B., Chen, H., et al. (2006). Mice lacking adiponectin show decreased hepatic insulin sensitivity and reduced responsiveness to peroxisome proliferator-activated receptor gamma agonists. *J Biol Chem* 281, 2654-2660.

Overgaard, J., Tomcala, A., Sorensen, J.G., Holmstrup, M., Krogh, P.H., Simek, P., and Kostal, V. (2008). Effects of acclimation temperature on thermal tolerance and membrane phospholipid composition in the fruit fly *Drosophila melanogaster*. *J Insect Physiol* 54, 619-629.

Owen, D.M., Rentero, C., Magenau, A., Abu-Siniyeh, A., and Gaus, K. (2011). Quantitative imaging of membrane lipid order in cells and organisms. *Nat Protoc* 7, 24-35.

Papanayotou, C., De Almeida, I., Liao, P., Oliveira, N.M., Lu, S.Q., Kougioumtzidou, E., Zhu, L., Shaw, A., Sheng, G., Streit, A., et al. (2013). Calfacilitin is a calcium channel modulator essential for initiation of neural plate development. *Nat Commun* 4, 1837.

Parker-Duffen, J.L., Nakamura, K., Silver, M., Zuriaga, M.A., MacLauchlan, S., Aprahamian, T.R., and Walsh, K. (2014). Divergent roles for adiponectin receptor 1 (AdipoR1) and AdipoR2 in mediating revascularization and metabolic dysfunction in vivo. *J Biol Chem* 289, 16200-16213.

Perez, C.L., and Van Gilst, M.R. (2008). A <sup>13</sup>C isotope labeling strategy reveals the influence of insulin signaling on lipogenesis in *C. elegans*. *Cell Metab* 8, 266-274.

Peyou-Ndi, M.M., Watts, J.L., and Browse, J. (2000). Identification and characterization of an animal delta(12) fatty acid desaturase gene by heterologous expression in *Saccharomyces cerevisiae*. *Arch Biochem Biophys* 376, 399-408.

Pilon, M. (2016). Revisiting the membrane-centric view of diabetes. *Lipids Health Dis* 15, 167.

Poppelreuther, M., Rudolph, B., Du, C., Grossmann, R., Becker, M., Thiele, C., Eehalt, R., and Fullekrug, J. (2012). The N-terminal region of acyl-CoA synthetase 3 is essential for both the localization on lipid droplets and the function in fatty acid uptake. *J Lipid Res* 53, 888-900.

Promlek, T., Ishiwata-Kimata, Y., Shido, M., Sakuramoto, M., Kohno, K., and Kimata, Y. (2011). Membrane aberrancy and unfolded proteins activate the endoplasmic reticulum stress sensor Ire1 in different ways. *Mol Biol Cell* 22, 3520-3532.

Pruitt, N.L. (1988). Membrane lipid composition and overwintering strategy in thermally acclimated crayfish. *Am J Physiol* 254, R870-876.

- Rappleye, C.A., Tagawa, A., Le Bot, N., Ahringer, J., and Aroian, R.V. (2003). Involvement of fatty acid pathways and cortical interaction of the pronuclear complex in *Caenorhabditis elegans* embryonic polarity. *BMC Dev Biol* 3, 8.
- Ruiz, M., Bodhicharla, R., Stahlman, M., Svensk, E., Busayavalasa, K., Palmgren, H., Ruhanen, H., Boren, J., and Pilon, M. (2019a). Evolutionarily conserved long-chain Acyl-CoA synthetases regulate membrane composition and fluidity. *Elife* 8.
- Ruiz, M., Bodhicharla, R., Svensk, E., Devkota, R., Busayavalasa, K., Palmgren, H., Stahlman, M., Boren, J., and Pilon, M. (2018). Membrane fluidity is regulated by the *C. elegans* transmembrane protein FLD-1 and its human homologs TLCD1/2. *Elife* 7.
- Ruiz, M., Stahlman, M., Boren, J., and Pilon, M. (2019b). AdipoR1 and AdipoR2 maintain membrane fluidity in most human cell types and independently of adiponectin. *J Lipid Res* 60, 995-1004.
- Savory, F.R., Sait, S.M., and Hope, I.A. (2011). DAF-16 and Delta9 desaturase genes promote cold tolerance in long-lived *Caenorhabditis elegans* age-1 mutants. *PLoS One* 6, e24550.
- Scheer, A., Fanelli, F., Costa, T., De Benedetti, P.G., and Cotecchia, S. (1996). Constitutively active mutants of the alpha 1B-adrenergic receptor: role of highly conserved polar amino acids in receptor activation. *EMBO J* 15, 3566-3578.
- Schneider, C.A., Rasband, W.S., and Eliceiri, K.W. (2012). NIH Image to ImageJ: 25 years of image analysis. *Nat Methods* 9, 671-675.
- Shaffer, A.L., Shapiro-Shelef, M., Iwakoshi, N.N., Lee, A.H., Qian, S.B., Zhao, H., Yu, X., Yang, L., Tan, B.K., Rosenwald, A., et al. (2004). XBP1, downstream of Blimp-1, expands the secretory apparatus and other organelles, and increases protein synthesis in plasma cell differentiation. *Immunity* 21, 81-93.
- Shimizu, T. (2009). Lipid mediators in health and disease: enzymes and receptors as therapeutic targets for the regulation of immunity and inflammation. *Annu Rev Pharmacol Toxicol* 49, 123-150.
- Shindou, H., Koso, H., Sasaki, J., Nakanishi, H., Sagara, H., Nakagawa, K.M., Takahashi, Y., Hishikawa, D., Iizuka-Hishikawa, Y., Tokumasu, F., et al. (2017). Docosahexaenoic acid preserves visual function by maintaining correct disc morphology in retinal photoreceptor cells. *J Biol Chem* 292, 12054-12064.
- Shindou, H., and Shimizu, T. (2009). Acyl-CoA:lysophospholipid acyltransferases. *J Biol Chem* 284, 1-5.
- Sluch, V.M., Banks, A., Li, H., Crowley, M.A., Davis, V., Xiang, C., Yang, J., Demirs, J.T., Vrouvlianis, J., Leehy, B., et al. (2018). ADIPOR1 is essential for vision and its RPE expression is lost in the Mfrp(rd6) mouse. *Sci Rep* 8, 14339.

- Smulan, L.J., Ding, W., Freinkman, E., Gujja, S., Edwards, Y.J.K., and Walker, A.K. (2016). Cholesterol-Independent SREBP-1 Maturation Is Linked to ARF1 Inactivation. *Cell Rep* 16, 9-18.
- Soupene, E., and Kuypers, F.A. (2008). Mammalian long-chain acyl-CoA synthetases. *Exp Biol Med (Maywood)* 233, 507-521.
- Spychalla, J.P., Kinney, A.J., and Browse, J. (1997). Identification of an animal omega-3 fatty acid desaturase by heterologous expression in Arabidopsis. *Proc Natl Acad Sci U S A* 94, 1142-1147.
- Sriburi, R., Bommasamy, H., Buldak, G.L., Robbins, G.R., Frank, M., Jackowski, S., and Brewer, J.W. (2007). Coordinate regulation of phospholipid biosynthesis and secretory pathway gene expression in XBP-1(S)-induced endoplasmic reticulum biogenesis. *J Biol Chem* 282, 7024-7034.
- Srinivasan, S. (2015). Regulation of body fat in *Caenorhabditis elegans*. *Annu Rev Physiol* 77, 161-178.
- Stiernagle, T. (2006). Maintenance of *C. elegans*. *WormBook*, 1-11.
- Subczynski, W.K., Pasenkiewicz-Gierula, M., Widomska, J., Mainali, L., and Raguz, M. (2017). High Cholesterol/Low Cholesterol: Effects in Biological Membranes: A Review. *Cell Biochem Biophys* 75, 369-385.
- Suutari, M., and Laakso, S. (1992). Changes in fatty acid branching and unsaturation of *Streptomyces griseus* and *Brevibacterium fermentans* as a response to growth temperature. *Appl Environ Microbiol* 58, 2338-2340.
- Svensk, E., Biermann, J., Hammarsten, S., Magnusson, F., and Pilon, M. (2016a). Leveraging the withered tail tip phenotype in *C. elegans* to identify proteins that influence membrane properties. *Worm* 5, e1206171.
- Svensk, E., Devkota, R., Stahlman, M., Ranji, P., Rauthan, M., Magnusson, F., Hammarsten, S., Johansson, M., Boren, J., and Pilon, M. (2016b). *Caenorhabditis elegans* PAQR-2 and IGLR-2 Protect against Glucose Toxicity by Modulating Membrane Lipid Composition. *PLoS Genet* 12, e1005982.
- Svensk, E., Stahlman, M., Andersson, C.H., Johansson, M., Boren, J., and Pilon, M. (2013). PAQR-2 regulates fatty acid desaturation during cold adaptation in *C. elegans*. *PLoS Genet* 9, e1003801.
- Svensson, E., Olsen, L., Morck, C., Brackmann, C., Enejder, A., Faergeman, N.J., and Pilon, M. (2011). The adiponectin receptor homologs in *C. elegans* promote energy utilization and homeostasis. *PLoS One* 6, e21343.

- Tanabe, H., Fujii, Y., Okada-Iwabu, M., Iwabu, M., Nakamura, Y., Hosaka, T., Motoyama, K., Ikeda, M., Wakiyama, M., Terada, T., et al. (2015a). Crystal structures of the human adiponectin receptors. *Nature* *520*, 312-316.
- Tanabe, H., Motoyama, K., Ikeda, M., Wakiyama, M., Terada, T., Ohsawa, N., Hosaka, T., Hato, M., Fujii, Y., Nakamura, Y., et al. (2015b). Expression, purification, crystallization, and preliminary X-ray crystallographic studies of the human adiponectin receptors, AdipoR1 and AdipoR2. *J Struct Funct Genomics* *16*, 11-23.
- Tanaka, T., Ikita, K., Ashida, T., Motoyama, Y., Yamaguchi, Y., and Satouchi, K. (1996). Effects of growth temperature on the fatty acid composition of the free-living nematode *Caenorhabditis elegans*. *Lipids* *31*, 1173-1178.
- Tang, Y.T., Hu, T., Arterburn, M., Boyle, B., Bright, J.M., Emtage, P.C., and Funk, W.D. (2005). PAQR proteins: a novel membrane receptor family defined by an ancient 7-transmembrane pass motif. *J Mol Evol* *61*, 372-380.
- Taubert, S., Van Gilst, M.R., Hansen, M., and Yamamoto, K.R. (2006). A Mediator subunit, MDT-15, integrates regulation of fatty acid metabolism by NHR-49-dependent and -independent pathways in *C. elegans*. *Genes Dev* *20*, 1137-1149.
- Thompson, O., Edgley, M., Strasbourger, P., Flibotte, S., Ewing, B., Adair, R., Au, V., Chaudhry, I., Fernando, L., Hutter, H., et al. (2013). The million mutation project: a new approach to genetics in *Caenorhabditis elegans*. *Genome Res* *23*, 1749-1762.
- Van Gilst, M.R., Hadjivassiliou, H., Jolly, A., and Yamamoto, K.R. (2005). Nuclear hormone receptor NHR-49 controls fat consumption and fatty acid composition in *C. elegans*. *PLoS Biol* *3*, e53.
- van Meer, G., Voelker, D.R., and Feigenson, G.W. (2008). Membrane lipids: where they are and how they behave. *Nat Rev Mol Cell Biol* *9*, 112-124.
- Vasiliauskaite-Brooks, I., Sounier, R., Rochaix, P., Bellot, G., Fortier, M., Hoh, F., De Colibus, L., Bechara, C., Saied, E.M., Arenz, C., et al. (2017). Structural insights into adiponectin receptors suggest ceramidase activity. *Nature* *544*, 120-123.
- Villa, N.Y., Kupchak, B.R., Garitaonandia, I., Smith, J.L., Alonso, E., Alford, C., Cowart, L.A., Hannun, Y.A., and Lyons, T.J. (2009). Sphingolipids function as downstream effectors of a fungal PAQR. *Mol Pharmacol* *75*, 866-875.
- Vinci, G., Xia, X., and Veitia, R.A. (2008). Preservation of genes involved in sterol metabolism in cholesterol auxotrophs: facts and hypotheses. *PLoS One* *3*, e2883.
- Walker, A.K., Jacobs, R.L., Watts, J.L., Rottiers, V., Jiang, K., Finnegan, D.M., Shioda, T., Hansen, M., Yang, F., Niebergall, L.J., et al. (2011). A conserved SREBP-1/phosphatidylcholine feedback circuit regulates lipogenesis in metazoans. *Cell* *147*, 840-852.

Wallis, J.G., Watts, J.L., and Browse, J. (2002). Polyunsaturated fatty acid synthesis: what will they think of next? *Trends Biochem Sci* 27, 467.

Watkins, P.A., Maiguel, D., Jia, Z., and Pevsner, J. (2007). Evidence for 26 distinct acyl-coenzyme A synthetase genes in the human genome. *J Lipid Res* 48, 2736-2750.

Watts, J.L. (2009). Fat synthesis and adiposity regulation in *Caenorhabditis elegans*. *Trends Endocrinol Metab* 20, 58-65.

Watts, J.L. (2016). Using *Caenorhabditis elegans* to Uncover Conserved Functions of Omega-3 and Omega-6 Fatty Acids. *J Clin Med* 5.

Watts, J.L., and Browse, J. (1999). Isolation and characterization of a Delta 5-fatty acid desaturase from *Caenorhabditis elegans*. *Arch Biochem Biophys* 362, 175-182.

Watts, J.L., and Browse, J. (2000). A palmitoyl-CoA-specific delta9 fatty acid desaturase from *Caenorhabditis elegans*. *Biochem Biophys Res Commun* 272, 263-269.

Watts, J.L., and Browse, J. (2002). Genetic dissection of polyunsaturated fatty acid synthesis in *Caenorhabditis elegans*. *Proc Natl Acad Sci U S A* 99, 5854-5859.

Watts, J.L., Phillips, E., Griffing, K.R., and Browse, J. (2003). Deficiencies in C20 polyunsaturated fatty acids cause behavioral and developmental defects in *Caenorhabditis elegans* fat-3 mutants. *Genetics* 163, 581-589.

Watts, J.L., and Ristow, M. (2017). Lipid and Carbohydrate Metabolism in *Caenorhabditis elegans*. *Genetics* 207, 413-446.

Wess, J. (1997). G-protein-coupled receptors: molecular mechanisms involved in receptor activation and selectivity of G-protein recognition. *FASEB J* 11, 346-354.

Winter, E., and Ponting, C.P. (2002). TRAM, LAG1 and CLN8: members of a novel family of lipid-sensing domains? *Trends Biochem Sci* 27, 381-383.

Xu, D., Wang, Z., Zhang, Y., Jiang, W., Pan, Y., Song, B.L., and Chen, Y. (2015). PAQR3 modulates cholesterol homeostasis by anchoring Scap/SREBP complex to the Golgi apparatus. *Nat Commun* 6, 8100.

Xu, M., Eblimit, A., Wang, J., Li, J., Wang, F., Zhao, L., Wang, X., Xiao, N., Li, Y., Wong, L.J., et al. (2016). ADIPOR1 Is Mutated in Syndromic Retinitis Pigmentosa. *Hum Mutat* 37, 246-249.

Yabuuchi, H., and O'Brien, J.S. (1968). Positional distribution of fatty acids in glycerophosphatides of bovine gray matter. *J Lipid Res* 9, 65-67.

Yamaji-Hasegawa, A., Takahashi, A., Tetsuka, Y., Senoh, Y., and Kobayashi, T. (2005). Fungal metabolite sulfamisterin suppresses sphingolipid synthesis through inhibition of serine palmitoyltransferase. *Biochemistry* 44, 268-277.

- Yamauchi, T., Kamon, J., Ito, Y., Tsuchida, A., Yokomizo, T., Kita, S., Sugiyama, T., Miyagishi, M., Hara, K., Tsunoda, M., et al. (2003a). Cloning of adiponectin receptors that mediate antidiabetic metabolic effects. *Nature* *423*, 762-769.
- Yamauchi, T., Kamon, J., Waki, H., Imai, Y., Shimozawa, N., Hioki, K., Uchida, S., Ito, Y., Takakuwa, K., Matsui, J., et al. (2003b). Globular adiponectin protected ob/ob mice from diabetes and ApoE-deficient mice from atherosclerosis. *J Biol Chem* *278*, 2461-2468.
- Yamauchi, T., Kamon, J., Waki, H., Terauchi, Y., Kubota, N., Hara, K., Mori, Y., Ide, T., Murakami, K., Tsuboyama-Kasaoka, N., et al. (2001). The fat-derived hormone adiponectin reverses insulin resistance associated with both lipoatrophy and obesity. *Nat Med* *7*, 941-946.
- Yamauchi, T., Nio, Y., Maki, T., Kobayashi, M., Takazawa, T., Iwabuchi, M., Okada-Iwabuchi, M., Kawamoto, S., Kubota, N., Kubota, T., et al. (2007). Targeted disruption of AdipoR1 and AdipoR2 causes abrogation of adiponectin binding and metabolic actions. *Nat Med* *13*, 332-339.
- Yang, F., Vought, B.W., Satterlee, J.S., Walker, A.K., Jim Sun, Z.Y., Watts, J.L., DeBeaumont, R., Saito, R.M., Hyberts, S.G., Yang, S., et al. (2006). An ARC/Mediator subunit required for SREBP control of cholesterol and lipid homeostasis. *Nature* *442*, 700-704.
- Yang, X., Sheng, W., Sun, G.Y., and Lee, J.C. (2011). Effects of fatty acid unsaturation numbers on membrane fluidity and alpha-secretase-dependent amyloid precursor protein processing. *Neurochem Int* *58*, 321-329.
- Yeagle, P.L. (1985). Cholesterol and the cell membrane. *Biochim Biophys Acta* *822*, 267-287.
- Yokomizo, T., Izumi, T., Chang, K., Takakuwa, Y., and Shimizu, T. (1997). A G-protein-coupled receptor for leukotriene B<sub>4</sub> that mediates chemotaxis. *Nature* *387*, 620-624.
- Zhang, J., Wang, C., Shen, Y., Chen, N., Wang, L., Liang, L., Guo, T., Yin, X., Ma, Z., Zhang, B., et al. (2016). A mutation in ADIPOR1 causes nonsyndromic autosomal dominant retinitis pigmentosa. *Hum Genet* *135*, 1375-1387.
- Zhou, M., Morais-Cabral, J.H., Mann, S., and MacKinnon, R. (2001). Potassium channel receptor site for the inactivation gate and quaternary amine inhibitors. *Nature* *411*, 657-661.
- Zhu, X.G., Nicholson Puthenveedu, S., Shen, Y., La, K., Ozlu, C., Wang, T., Klompstra, D., Gultekin, Y., Chi, J., Fidelin, J., et al. (2019). CHP1 Regulates Compartmentalized Glycerolipid Synthesis by Activating GPAT4. *Mol Cell* *74*, 45-58 e47.
- Zhu, Y., Bond, J., and Thomas, P. (2003a). Identification, classification, and partial characterization of genes in humans and other vertebrates homologous to a fish membrane progesterin receptor. *Proc Natl Acad Sci U S A* *100*, 2237-2242.



Zhu, Y., Rice, C.D., Pang, Y., Pace, M., and Thomas, P. (2003b). Cloning, expression, and characterization of a membrane progestin receptor and evidence it is an intermediary in meiotic maturation of fish oocytes. *Proc Natl Acad Sci U S A* *100*, 2231-2236.